



From Hillsboro, Ohio, Randy Wilkin's 1946 truck

ENGINE SECTION GLOSSARY

<i>Engine Identification Charts for</i>	
<i>1939-54 Champion or Commander.....</i>	<i>160</i>
<i>1955-64 Car.....</i>	<i>161</i>
<i>Trucks: 1941-56.....</i>	<i>162</i>
<i>Trucks: 1957-63.....</i>	<i>163</i>
<i>Cylinder Heads & Gaskets</i>	<i>164</i>
<i>Motor Mounts & Kits.....</i>	<i>164-165</i>
<i>McKinnon Engine Gaskets & Seals.....</i>	<i>166</i>
<i>Crankshaft</i>	<i>168-169</i>
<i>Camshaft.....</i>	<i>169</i>
<i>Main Bearings & Rods.....</i>	<i>170</i>
<i>Pistons</i>	<i>171</i>
<i>Oil Pumps & Related Parts.....</i>	<i>172-173</i>
<i>Valves</i>	<i>174-175</i>
<i>Manifold & Exhaust</i>	<i>176-177</i>
<i>Gasket & Seal Sets.....</i>	<i>178-179</i>
<i>Blocks & Frame Brackets.....</i>	<i>180</i>
<i>Major & Minor Rebuild Kits</i>	<i>181-182</i>



The following charts are designed to help you identify the type of engine in your car.
 At the top of each chart is "where to look" directions to help you locate the serial & engine numbers.
 If you're unsure what year or model your car is, then use the starting engine numbers listed below.

1939-42 & 1946 CHAMPION

CAR SERIAL NUMBER PLATE: 1939 CHAMPION: Under the front fender, left side of frame
 1940 CHAMPION: Either on the left front door hinge pillar or under the front fender, left side of frame
 1941-42 CHAMPION: Left front door hinge pillar

ENGINE NUMBER: 1939-42 CHAMPION: Top left side, front corner of the cylinder block

YEAR & MODEL	STARTING ENGINE NUMBER	YEAR & MODEL	STARTING ENGINE NUMBER
1939 Champion	101	1942 Champion	186,301
1940 Champion	34,101	1946 Champion	216,501
1941 Champion	101,201		

Note: A "C" anywhere in your engine number indicates your car was built in Canada

1947-50 CHAMPION & COMMANDER

CAR SERIAL NUMBER PLATE: Left, front door lock pillar post

ENGINE NUMBER: Stamped on a boss at the top, left side, front corner of the cylinder block

YEAR & MODEL	STARTING ENGINE NUMBER	YEAR & MODEL	STARTING ENGINE NUMBER
1947 Champion	236,001	1947 Commander	H-182,001
1948 Champion	342,001, C-1,101	1948 Commander	H-238,001
1949 Champion	441,001, C-4,101	1949 Commander	H-326,001
1950 Champion	521,001, C-10,501	1950 Commander	H-370,001

Note: A "C" anywhere in your engine number indicates your car was built in Canada

1951-54 CHAMPION & COMMANDER

CAR SERIAL NUMBER PLATE: 1951-52 SERIES- left, front door lock pillar post
 1953-54 SERIES- left, front door hinge pillar

ENGINE NUMBER: CHAMPION - Stamped on a boss at the top left side, front corner of the cylinder block

1951-52 COMMANDER - stamped on a boss at the top side, rear end of cylinder block next to the distributor

1953-54 COMMANDER - stamped on a boss at the top side, front end of cylinder block next to the fuel pump support

YEAR & MODEL	STARTING ENGINE NUMBER	YEAR & MODEL	STARTING ENGINE NUMBER
1951 Champion	778,001, C-25,501	1951 Commander	V-101, VC-101
1952 Champion	911,501, C-36,722	1952 Commander	V-123,001, VC-2,036
1953 Champion	1,004,001, C-46,501	1953 Commander	V-207,001, VC-3,501
1954 Champion	1,090,001, C-55,782	1954 Commander	V-282,501, *VC-4,941

1955-58 CHAMPION, COMMANDER & PRESIDENT 1957-58 GOLDEN HAWK, PACKARD & CLIPPER

CAR SERIAL NUMBER PLATE: *Left front door hinge pillar*

ENGINE NUMBER: *Champion - stamped on a boss at the top, left side, front corner of the cylinder block*

Commander - stamped on a boss at the top, front end of cylinder block, next to the oil filler tube

President - stamped on a boss at the top, front end of cylinder block, next to the oil filler tube

Golden Hawk - stamped on a boss at the top, front end of cylinder block, next to the oil filler tube

Packard - stamped on a boss at the top, front end of cylinder block, next to the oil filler tube

YEAR & MODEL	STARTING ENGINE NUMBER	YEAR & MODEL	STARTING ENGINE NUMBER
1955 Champion	1,138,001, L-101, C-60,501	1957 Commander	V-390,001 VC-10,701
1955 Commander	V-312,701, V-331,101, VL-101, VC-5,701, VC-6,201	1957 Golden Hawk	PS-1,001
1955 President	P-101, PL-101, PC-101	1957 President	P-39,601, PC-1,501
1956 Champion	C-66,001, VC-8,101, 1,180,251, L-3,201	1958 Champion	1,228,401, C-74,701
1956 Commander	V-363,751 VL-6,301 VC8,101	1958 Commander	V-407,501, VC-13,301
1956 President	P-22,001 PL-2,701 PC-601	1958 Golden Hawk	PS-5,501
1957 Champion	1,202,101, C-71,401	1958 Packard	L-101
1957 Clipper	LS-101	1958 Packard Hawk	LS-5,201

1959-64 CAR EXCLUDING AVANTI

CAR SERIAL NUMBER PLATE: *Left front door hinge pillar*

ENGINE NUMBER: *SIXES - Stamped on a boss at the top left side, front corner of the cylinder block*

EIGHTS - Stamped on a boss at the top, front end of the cylinder block

ENGINE ID FOR 1964 MODELS

V	8-259 ENGINE	JT	JET THRUST
VC	8-259 ENGINE, CANADA	JTS	JET THRUST SUPERCHARGED
P	8-289 ENGINE	JTC	JET THRUST, CANADA
PC	8-289 ENGINE, CANADA	JTSC	JET THRUST SUPERCHARGED, CANADA
S	6-170 ENGINE	SC	6-170 ENGINE, CANADA

YEAR & MODEL	STARTING ENGINE NUMBER	YEAR & MODEL	STARTING ENGINE NUMBER
1959 6 Cylinder	S-10,001, SC-10,001	1959 8 Cylinder	V-418,701, VC-14,701
1960 6 Cylinder	S-106,001, SC-15,501	1960 8 Cylinder	V-454,701, P-70,501, VC-16,701, PC-2,201
1961 6 Cylinder	S-172,601, SC-20,101	1961 8 Cylinder	V-510,401, P-74,701, VC-18,501, PC-2,501
1962 6 Cylinder	S-210,901, SC-24,301	1962 8 Cylinder	V-534,901, P-79,801, VC-19,601, PC-2,801
1963 6 Cylinder	S-261,201, SC-29,701	1963 8 Cylinder	V-566,601, P-93,601, JT-1,001, JTS-1,001, VC-21,401, PC-3,401 JTC-1,001, JTSC-1,001
1964 6 Cylinder	SEE ENGINE ID	1964 8 Cylinder	SEE ENGINE ID

AVANTI 1963-64

CAR SERIAL NUMBER PLATE: *Right frame side rail in front of No. 1 body hold down bracket*

ENGINE NUMBER: *stamped on boss at top, front end of cylinder block, next to left front corner of lifter cover*

YEAR & MODEL	STARTING ENGINE NUMBER
1963-64 Avanti	R-1001, RS-1001

R- 8-289 ENGINE WITH ONE 4BBL CARBURETOR • RS- 8-289 ENGINE WITH ONE 4BBL CARBURETOR, SUPERCHARGED

The following charts are designed to help you identify the type of engine in your car.
 At the top of each chart is "where to look" directions to help you locate the serial & engine numbers.
 If you're unsure what year or model your car is, then use the starting engine numbers listed below.

TRUCK 1941-48

TRUCK SERIAL NUMBER: On left side of the seat riser

ENGINE NUMBER: Stamped on top, left side, front corner of the cylinder block

YEAR & MODEL	STARTING ENGINE NUMBER	YEAR & MODEL	STARTING ENGINE NUMBER
1941-48 M-5	1M-001	1946-48 M-15	2M-6401
1941-42 M-15	2M-001	1941-48 M-16	3M-001
1945 M-15	2M-2001	1946-48 M-17	3M-6101

TRUCK 1949-56

TRUCK SERIAL NUMBER PLATE: On left side of the seat riser

ENGINE NUMBER: 6-CYLINDER - Top left side, front corner of the cylinder block

V-8 - Top front end of cylinder block next to the oil filler

YEAR & MODEL	STARTING ENGINE NUMBER	YEAR & MODEL	STARTING ENGINE NUMBER
1949-53 2R 5 6-cylinder	1R-001, H1R-001	1955 E 6 6-cylinder	4E-101
1949-53 2R 6 6-cylinder	6R-101	1955 E 7 V-8	2E-101
1949-53 2R 10 6-cylinder	1R-001	1955 E 10 6-cylinder	1E-101
1949-53 2R 11 6-cylinder	6R-101	1955 E 11 6-cylinder	4E-101
1949-53 2R 14 6-cylinder	6R-101	1955 E 12 V-8	2E-101
1949-53 2R 15 6-cylinder	2R-001	1955 E 13 V-8	1E-101
1949-53 2R 16 6-cylinder	3R-001	1955 E 14 6-cylinder	4E-101
1949-53 2R 16A 6-cylinder	4R-101	1955 E 15 6-cylinder	2E-101
1949-53 2R 17 6-cylinder	3R-001	1955 E 16 6-cylinder	4E-101
1949-53 2R 17A 6-cylinder	4R-001	1955 E 17 6-cylinder	4E-101
1954 3R 5 6-cylinder	1R-149,001, H1R-6,575	1955 E 28 V-8	3E-101
1954 3R 6 6-cylinder	6R-24,701	1955 E 38 V-8	5E-101
1954 3R 10 6-cylinder	1R-149,001	1956 2E 5 6-cylinder	1E-6,051, H1E-401
1954 3R 11 6-cylinder	6R-24,701	1956 2E 6 6-cylinder	4E-2,351
1954 3R 14 6-cylinder	6R-24,701	1956 2E 7 V-8	2E-7,001
1954 3R 15 6-cylinder	2R-14,201	1956 2E 10 6-cylinder	1E-6,051
1954 3R 16 6-cylinder	4R-59,001	1956 2E 11 6-cylinder	4E-2,351
1954 3R 17 6-cylinder	4R,59,001	1956 2E 12 V-8	2E-7,001
1954 3R 28 V-8	VT-2,301	1956 2E 13 V-8	3E-1,301
1954 3R 38 V-8	VT-2,301	1956 2E 14 6-cylinder	4E-2,351
1955 E 5 6-cylinder	1E-101, H1E-101	1956 2E 28 V-8	3E-1,301
		1956 2E 38 V-8	5E-3,501

*WHEN 259 HEAVY DUTY ENGINE IS INSTALLED IN THESE MODELS THE ENGINE WILL BE IDENTIFIED BY A 5E NUMBER.

•WHEN 289 STANDARD ENGINE IS INSTALLED IN THESE MODELS THE ENGINE WILL BE IDENTIFIED BY A 7E NUMBER.

•WHEN 289 HEAVY DUTY ENGINE IS INSTALLED IN THESE MODELS THE ENGINE WILL BE IDENTIFIED BY A 6E NUMBER.

HEAVY DUTY ENGINES WILL BE FURTHER IDENTIFIED BY THE STENCILED CLOVER LEAF SYMBOL ON THE ENGINE NUMBER

TRUCK 1957-61

TRUCK SERIAL NUMBER PLATE: *On left side of the seat riser*
ENGINE NUMBER: *6-CYLINDER - Top left side, front corner of the cylinder block*
V-8 - Top, front end of the cylinder block next to the oil filler

YEAR & MODEL	STARTING ENGINE NUMBER	YEAR & MODEL	STARTING ENGINE NUMBER
1957-58 3E 5 6-cylinder	1E-10,101	1959 4E 14,14D 6-cylinder	4E-7,301
1957-58 3E 6, 6D 6-cylinder	4E-3,401	1959 4E 16 6-cylinder	4E-7,301
1957-58 3E 7, 7D V-8	3E-2,701*	1959 4E 28 V-8	3E-8,001*
1957-58 3E 10 6-cylinder	1E-10,101	1959 4E 40 V-8	6E-2,401*
1957-58 3E 11, 11D 6-cylinder	4E-3,401	1960 5E 5 6-cylinder	1E-18,301
1957-58 3E 12, 12D V-8	3E-2,701*	1960 5E 6 6-cylinder	4E-9,401
1957-58 3E 13 V-8	3E-2,701*	1960 5E 7 V-8	3E-9,201*
1957-58 3E 14 6-cylinder	4E-3,401	1960 5E 11 6-cylinder	4E-9,401
1957-58 3E 16 6-cylinder	4E-3,401	1960 5E 12 V-8	3E-9,201*
1957-58 3E 17 6-cylinder	4E-3,401	1960 5E 13,13D V-8	3E-9,201*
1957-58 3E 28 V-8	3E-2,701*	1960 5E 14,14D 6-cylinder	4E-9,401
1957-58 3E 38 V-8	5E-6,501*	1960 5E 16 6-cylinder	4E-9,401
1957-58 3E 40 V-8	6E-101	1960 5E 28 V-8	3E-9,201*
1959 4E 1 6-cylinder	1E-15,001	1960 5E 40 V-8	6E-3,901
1959 4E 2, 2D V-8	3E-8,001*	1961 6E 5 6-cylinder	1E-20,601
1959 4E 3, 3 D 6-cylinder	4E-7,301	1961 6E 7 V-8	3E-11,601*
1959 4E 5 6-cylinder	1E-15,001	1961 6E 10 6-cylinder	1E-20,601
1959 4E 6, 6D 6-cylinder	4E-7,301	1961 6E 12 V-8	3E-11,601*
1959 4E 7, 7D V-8	3E-8,001*	1961 6E 13,13D V-8	3E-11,601*
1959 4E 11, 11D 6-cylinder	4E-7,301	1961 6E 28 V-8	3E-11,601*
1959 4E 12, 12D V-8	3E-8,001*	1961 6E 40 V-8	6E-4,601*
1959 4E 13, 13D V-8	3E-8,001*		

TRUCK 1962-63

TRUCK SERIAL NUMBER PLATE: *On left side of the seat riser*
ENGINE NUMBER: *6-CYLINDER - Top left side, front corner of the cylinder block*
V-8 - Top, front end of the cylinder block next to the oil filler

YEAR & MODEL	STARTING ENGINE NUMBER	YEAR & MODEL	STARTING ENGINE NUMBER
1962 7E 5 6-cylinder	1E-23,901	1963 8E 7 V-8	3E-18,901*
1962 7E 7 V-8	3E-14,801*	1963 8E 10 6-cylinder	1E-27,801
1962 7E 10 6-cylinder	1E-23,901	1963 8E 12 V-8	3E-18,901*
1962 7E 12 V-8	3E-14,801*	1963 8E 13, 13D V-8	3E-18,901*
1962 7E 13, 13D V-8	3E-14,801*	1963 8E 15 3-cylinder	3D-4,000
1962 7E 28A V-8	3E-14,801*	1963 8E 25 3-cylinder	3D-4,000
1962 7E 28C V-8	3E-14,801*	1963 8E 28A V-8	3E-18,901*
1962 7E 35A 4-cylinder	4D-4,000	1963 8E 28C V-8	3E-18,901*
1962 7E 35C 4-cylinder	4D-4,000	1963 8E 35A 4-cylinder	4D-5,000
1962 7E 40A V-8	6E-5,101*	1963 8E 35C 4-cylinder	4D-5,000
1962 7E 40E V-8	6E-5,101*	1963 8E 40A V-8	6E-5,501*
1962 7E 45A 4-cylinder	4D-4,000	1963 8E 40E V-8	6E-5,501*
1962 7E 45E 4-cylinder	4D-4,000	1963 8E 45A 4-cylinder	4D-5,000
1963 8E 5 6-cylinder	1E-27,801	1963 8E 45E 4-cylinder	4D-5,000

Exceptions to note on Left - *Standard engines will be identified by a 3E (259) or 7E (289) engine number. Heavy duty engines will be identified by a 5E (259) or 6E (289) engine number.

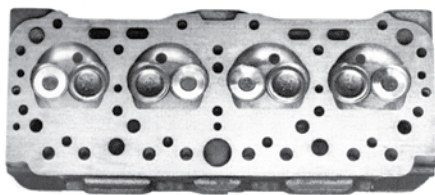

CYLINDER HEADS 6-Cylinder

- 1544289** 1958 185 cubic inch 6-cylinder. 7.5:1 compression ratio. **\$85.00 ea.**
- 1544290** Low compression. 1958 185 cubic inch 6-cylinder. **\$85.00 ea.**
- 1548294** Low compression. 1959-60 170 cubic inch 6-cylinder. **\$85.00 ea.**
- 1549218** 1959-60 170 cubic inch 6-cylinder. **\$85.00 ea.**
- 1564874** 1965- early 1966 194 cubic inch 6-cylinder. **\$250.00 ea.**
- 1565707** Late 1966 194 cubic inch 6-cylinder. **\$250.00 ea.**
- 1692061** 1938-60 Commander 6-cylinder. 7.5:1 compression ratio **\$105.00 ea.**
- 1692062** 1938-60 Commander 6-cylinder. **\$105.00 ea.**

MOTOR MOUNTS

- 180437** Front upper. 1939-46, 1951-52 Champion. 1941-42 & 1951-52 Commander. Truck: M5 & M15, 2R, 3R,E-8E.
All rear lower. 1937-38 Commander. 1937-38 Coupe Express. Truck: Rear upper. M16-M17 & 2R-8E all. **\$10.00 ea.**
- 191088** Front. Commander & Dictator: 1936-50 President: 1936-42 **\$60.00 ea.**
- 195801** Rear upper. 1937-40 Commander, 1937-39 Coupe Express & 1937-40 President. **\$16.50 ea.**
- 196717** Front. 1947-50 Champion. Rear. 1941-42 Commander, 1939-46 Champion & M5-M15 truck. **\$58.00 ea.**
- 519917** Spacer rear engine support 1947-49 Champion. **\$3.95 ea.**
- 520264** Rear upper. 1947-50 Champion. **\$37.50 ea.**
- 520265** Rear lower. 1947-49 Champion..... **\$18.00 ea.**
- 520987** Rear upper. 1947-50 Commander. Front upper. 1951-52 Commander. **\$9.50 ea.**
- 520988** Rear lower. 1947-49 Commander. **\$7.50 ea.**

CYLINDER HEAD GASKETS

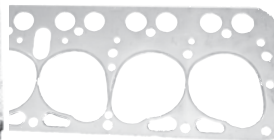

- 167033** 1929-32 Dictator, 1929-33 Commander 8 & 1933 President 8 model 82. **\$65.00 ea.**
- 178200** 1933 President 8 model 33. **\$65.00 ea.**
- 184442** 1934-37, 8 cylinder with cast iron head. **\$65.00 ea.**
- 184651** 1935 Dictator 6-cylinder with cast iron head. **\$45.00 ea.**
- 191829** 1938-42 President 8. **\$65.00 ea.**
- 527057** 1938-60 Commander 6-cylinder. **\$35.00 ea.**
- 529321** 1951-54 V-8 **\$15.00 ea.**
- 534598** 1939-60 Champion 6-cyl **\$44.00 ea.**
- 535982** 1955-64 V-8 & 1963-64 Avanti (thick). **\$40.00 ea.**
- 1545072** 1955-64 V-8 & 1963-64 Avanti (thin). **\$31.50 ea.**
- New Listing - 1564448** 1965-66 V-8. **\$10.00 ea.**
- New Listing - 1564876** 1965 6-cylinder. **\$10.00 ea.**
- New Listing - 1565709** 1966 6-cylinder. **\$10.00 ea.**
- 1693440** 1961-64 6-cylinder. .. **\$45.00 ea.**

CYLINDER HEADS V-8

- 527222** 1951-54 V-8, 7.0:1 compression ratio. **\$95.00 ea.**
- 535298** 1951-54 V-8, 7.5:1 compression ratio. **\$95.00 ea.**
- 536097** 1955-61 V-8, 7.5:1 compression ratio. **\$120.00 ea.**
- 1555295** 1962 V-8, 8.25:1 compression ratio. Only one. **\$250.00 ea.**
- 1557571** 1963-64 standard V-8, 8.25:1 compression ratio. Also, 10.25:1 compression ratio when used on R-1 engines. **\$300.00 ea.**
- 1557579** 1963-64 standard V-8, 8.5:1 compression ratio. Only one. **\$250.00 ea.**
- 1564859** 1965-66 V-8, 7.5:1 compression ratio. Only one. **\$250.00 ea.**
- 1564435** 1965-66 V-8, 9.25:1 compression ratio. **\$195.00 ea.**

DOWEL PIN

- 1554667** Dowel pin, cylinder head to block. 1951-64 V-8 all models & 1963-64 Avanti. Takes 4. **\$2.75 ea.**
- 800279**

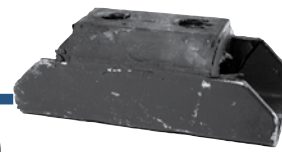

Rear. 1972-80 Avanti with auto trans. Takes 1. **\$14.00 ea.**

1564701

- Rear. 1965-66 Lark. 1966-71 Avanti, all models with automatic transmission Takes 1. **\$12.00 ea.**
- 800907** Front. 1963-64 Avanti R-3 & all V-8 models needing more engine and hood clearance. **\$14.50 ea.**



- 1553609** 4 speed, rear 1961-64 Lark & Hawk, 1963-64 Avanti 3 speed & 4 speed. Use 1547196 **\$75.00 ea.**
- 1547196** Rear. 1956-64 V-8 with standard trans. **\$75.00 ea.**



- 526308** Rear lower. 1950 Champion. **\$24.00 ea.**
- 526310** Rear lower. 1950 Commander. **\$16.50 ea.**
- 526471** Rear, automatic transmission. 1950-52 car & early E-2E 7, 12 truck. **\$75.00 pr.**
- 532425** Rear. 1953-55 car, all models with automatic transmission. **\$75.00 pr.**
- 530276** Front lower. 1951-52 V-8..... **\$14.00 ea.**
- 533296** Front. 1953-64 V-8, all models including Avanti. **\$16.50 ea.**
- 674993** Front lower. 1939-46 & 1951-52 Champion & 1941-42 Commander. Truck: 6-cylinder. M5-M17 & 2R-2E, 3R 28, 38 & 3E-5E 3, 6, 11, 14, 16, 17 & 3E-8E 1, 5, 10. **\$15.00 ea.**
- 674994** Truck: M16, M17, 2R-3R, 16, 17. E-8E, 7, 12, 13, 28, 38, 40. Lower front (V-8 only) and lower rear. **\$18.00 ea.**
- 677282** Rear. Truck: 2R-2E 5, 10, 15. 3E-6E 1, 5, 10. 7E 5, 10 **\$60.00 ea.**

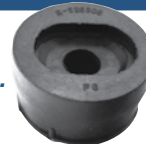

- 1564696** Front. 1965-66 6-cylinder..... **\$25.00 ea.**
- 1564698** Front. 1965-66 V-8 Lark. 1966-83 Avanti. Takes 2. **\$16.80 ea.**

1939-46 CHAMPION, 1941-42 COM-
MANDER, M5 & M15 TRUCKS

180437 (2) \$10.00 ea.
196717 (1) \$58.00 ea.
674993 (2) \$15.00 ea.

801577
Kit price \$108.00 ea.

1937-40 DICTATOR, COMMANDER
& PRESIDENT

180437 (2) \$10.00 ea.
191088 (1) \$60.00 ea.
195801 (2) \$16.50 ea.

801578
Kit price \$113.00 ea.

1947-49 CHAMPION

196717 (1) \$58.00 ea.
520264 (2) \$37.50 ea.
520265 (2) \$18.00 ea.

801579
Kit price \$169.00 ea.

1950 CHAMPION with standard trans.

196717 (1) \$58.00 ea.
520264 (2) \$37.50 ea.
526308 (2) \$24.00 ea.

801580
Kit price \$181.00 ea.

1947-49 COMMANDER

191088 (1) \$60.00 ea.
520987 (2) \$9.50 ea.
520988 (2) \$7.50 ea.

801581
Kit price \$94.00 ea.

1950 COMMANDER with standard trans.

191088 (1) \$60.00 ea.
520987 (2) \$9.50 ea.
526310 (2) \$16.50 ea.

801582
Kit price \$112.00 ea.

1950 CHAMPION with automatic trans.

196717 (1) \$58.00 ea.
526471 (1pr) \$75.00 pr.

801583
Kit price \$133.00 ea.

1950 COMMANDER with automatic trans.

191088 (1) \$60.00 ea.
526471 (1pr) \$75.00 pr.

801584
Kit price \$135.00 ea.

1951-52 CHAMPION with standard trans.

180437 (2) \$10.00 ea.
532258 (1) No Stock
674993 (2) \$15.00 ea.

801585
Kit price \$50.00 ea.

1951-52 CHAMPION with automatic trans.

180437 (2) \$10.00 ea.
526471 (1pr) \$75.00 pr.
674993 (2) \$15.00 ea.

801586
Kit price \$125.00 ea.

1953-54 CHAMPION with automatic trans.

532425 & 526471 \$75.00 pr.
1556995 (2) use 533296

801589
Kit price \$108.00 ea.

1953-54 COMMANDER
with automatic trans.

533296 (2) \$16.50 ea.
532425 & 526471 \$75.00 pr.

801590
Kit price \$108.00 ea.

1951-52 V-8 with standard trans.

520987 (2) \$9.50 ea.
530276 (2) \$14.00 ea.
532258 (1) No Stock

801591
Kit price \$47.00 ea.

1951-52 V-8 with automatic trans.

520987 (2) \$9.50 ea.
526471 (1pr) \$75.00 pr.
530276 (2) \$14.00 ea.

801592
Kit price \$122.00 ea.

Motor Mount Kits

1956-64 V-8 with standard trans.

1547196 (1) \$75.00 ea.
533296 (2) \$16.50 ea.

801927
Kit price \$108.00 ea.

1959-64 6-CYLINDER

with standard trans. except convertible

1556995 (4) use 533296

801596
Kit price \$66.00 ea.

1941-60 COMMANDER

6-CYLINDER TRUCK with standard trans.

180437 (4) \$10.00 ea.
674993 (2) \$15.00 ea.
674994 (2) \$18.00 ea.

801598
Kit price \$106.00

1954-64 V-8 TRUCKS
with standard trans.

180437 (4) \$10.00 ea.
674994 (4) \$18.00 ea.

801599
Kit price \$112.00 ea.



John Kelley's custom car looks
smarter than a Smart Fortwo!
Wonder if it's better on gas too?

FLY WHEEL WITH GEAR

1564409 1965-66 with standard and
overdrive transmission. 6-cylinder with heavy
duty clutch and all V-8. \$150.00 ea.
1685602 Truck: 3E-7E 1, 5, 10. ..\$175.00 ea.
1687115 Truck: 3E-8E 7, 12, 13, 28, 38, 40, with
11" or 12" clutch and 259 V-8. \$220.00 ea.

Engine - Motor Mount Kits & Flywheel

SHORT BLOCK GASKET & SEAL SETS

New!

McKinnon Short Block Gasket & Seal Set

for all 1965-66 6-cylinder car

Engine Gasket set includes:

- 1 Ea. 1564054.Timing cover seal
- 1 Ea. 1564055. Timing cover gasket
- 1 Ea. 1564061. Water pump
- 1 Ea. 1564080. inlet/exhaust manifold
- 1 Ea. 1564092.Fuel pump
- 1 Ea. 1564419.Rear main oil
- 1 Ea. 1564044.Oil pump

1564864
Special kit price..... \$5.00 ea.

New!

McKinnon Short Block Gasket & Seal Set

for all 1965-66 V-8 car

Engine Gasket set includes:

- 1 Ea. 1564054.Timing cover seal
- 1 Ea. 1564219. Timing cover gasket
- 1 Ea. 1564228. Water pump
- 1 Ea. 1564092.Fuel pump
- 1 Ea. 1564250.Fuel pump mount plate
- 1 Ea. 1565168.Rear main oil

1564393
Special kit price..... \$5.00 ea.

WHAT CAN I SAY?
I'M SPEECHLESS...



I FINALLY
FOUND THE PART
I WAS SEARCHING FOR
AT
STUDEBAKER
INTERNATIONAL!

NOW, I KNOW TO CALL
THEM FIRST!

317-462-3124

FAX: 462-8891

E-MAIL:
jim@studebaker-intl.com

The lucky ones, thankfully, on their way to a garage!



INDIVIDUAL MCKINNON GASKETS & SEALS

FOR ALL 1965 - 66 CAR
NEW Listing - 1563987 Valve stem. All.

-**¢.10 ea.**
- NEW Listing - 1564026** Front oil pan. 1965-66 6-cylinder..... **\$1.00 ea.**
- NEW Listing - 1564027** Rear oil pan. 1965-66 6-cylinder. **\$1.00 ea.**
- NEW Listing - 1564044** Oil pump cover. 1965-66 6-cylinder. **¢.50 ea.**
- NEW Listing - 1564054** Timing cover. 1965-66 all. **\$2.50 ea.**
- NEW Listing - 1564055** Timing cover. 1965-66 6-cylinder. **\$1.50 ea.**
- NEW Listing - 1564061** Water pump. 1965-66 6-cylinder. **¢.50 ea.**
- NEW Listing - 1564064** Thermostat housing to engine. 1965-66 6-cylinder. .**¢.50 ea.**
- 1564066** Water outlet. 1965-66 V-8 & 1966-85 Avanti. **\$1.50 ea.**
- 1564080** Inlet to exhaust manifold. 1965-66 6-cylinder. **\$1.50 ea.**
- NEW Listing - 1564084** Inlet and exhaust manifold to head. 1965-66 6-cylinder. **\$3.00 ea.**
- NEW Listing - 1564114** Distributor. 1965-66 6-cylinder. **¢.50 ea.**
- NEW Listing - 1564187** Front oil pan. 1965-66 V-8..... **\$1.00 ea.**
- NEW Listing - 1564188** Rear oil pan. 1965-66 V-8..... **\$1.00 ea.**
- NEW Listing - 1564215** Crankshaft to block. 1965-66 V-8. **¢.50 ea.**
- NEW Listing - 1564219** Timing cover. 1965-66 V-8..... **\$1.50 ea.**
- NEW Listing - 1564226** Water pump plate. 1965-66 V-8..... **\$2.50 ea.**
- NEW Listing - 1564228** Water pump. Takes 2. 1965-66 V-8..... **\$2.50 ea.**
- NEW Listing - 1564250** Fuel pump mounting plate gasket. **\$1.50 ea.**
- NEW Listing - 1564271** Distributor. 1965-66 V-8..... **¢.50 ea.**
- 1564336** Oil pan plug. 1965-66 all.. **\$1.00 ea.**
- NEW Listing - 1564419** Rear main oil. 1965-66 6-cylinder..... **\$4.00 ea.**
- NEW Listing - 1564442** Cylinder head. 1965-66 6-cylinder. **\$5.00 ea.**
- NEW Listing - 1564448** Cylinder head. 1965-66 V-8. **\$10.00 ea.**
- New Listing - 1564876** 1965 6-cylinder. **\$10.00 ea.**
- NEW Listing - 1564879** Oil filter to body. 1965-66 V-8. **¢.50 ea.**
- NEW Listing - 1565168** Rear main oil. 1965-66 V-8..... **\$5.00 ea.**
- NEW Listing - 1565336** Rocker cover. 1965-66 6-cylinder..... **\$4.00 ea.**
- NEW Listing - 1565709** Cylinder head. 1965-66 6-cylinder..... **\$10.00 ea.**



Brothers, Albert & Joe Kish, from the southern hills of Pennsylvania, are the proud owners of these two sharp looking 1956 President and 1957 Packard Clipper.

NOS CRANKSHAFTS



- 521525** 1941-50 Champion 6-cylinder. **\$650.00 ea.**
- 530081** 1951-54 V-8 232 cubic inch engine. **\$550.00 ea.**
- 1547105** 1959-60 6-cylinder 170 cubic inch engine. **\$550.00 ea.**
- 1550774** 1961 OHV 6-cylinder 170 cubic inch engine. **\$550.00 ea.**
- 1552397** 1955-58 185 6-cylinder. **\$550.00 ea.**
- 1556999** Late 1962-64 259 V-8. **\$255.00 ea.**
- 1558011** 1955 - early 62 259 V-8. **\$220.00 ea.**
- 1564432** 1965- early 1966 V-8. **\$450.00 ea.**
- 1564440** 1965-66 6-cylinder. **\$350.00 ea.**
- 1565717** Late 1966 V-8. **\$450.00 ea.**
- 1693393** Early 8E 6-cylinder truck with 10 1/2" clutch and 1962 OHV 6-cylinder. **\$400.00 ea.**
- 1697128** Late 8E 6-cylinder truck with 10 1/2" clutch 1962 OHV 6-cylinder. **\$400.00 ea.**

CRANKSHAFT

VENTILATOR ASSEMBLY
for 1965 - 66 V-8 car
NEW Listing - 1564213 . \$ 10.00 ea.



- ## FRONT CRANKSHAFT & TIMING COVER SEALS
- 167156** Front crankshaft washer seal. 1932-33 Rockne, 1931-34 Studebaker, 1934-42 Dictator, Commander, Coupe Express. 1929-33 Dictator & Commander 8, 1933 President 8 model 82, 1934-60 Commander 8 & President 8. 1951-64 V-8 & 1963-64 Avanti. **\$4.25 ea.**
- 186668** Cover gasket. 1936-60 Commander 6-cyl. **\$6.75 ea.**
- 194219** Cork cover gasket. 1939-54 Champion 6-cylinder. **\$6.75 ea.**
- 194484** Front plate gasket. 1939-54 Champion 6-cylinder. **\$6.75 ea.**
- 197591** Front crankshaft seal. 1939-64 Champion 6-cylinder. **\$4.25 ea.**
- 800393** Kit. 1955-64 Champion 6-cylinder. Includes: 1561172 cover gasket, 1561168 plate gasket & 197591 front crankshaft seal **\$17.50/set**
- 800394** Kit. 1955-64 V-8 & 1963-64 Avanti. Includes 1561166 cover gasket, 167156 front crankshaft washer seal, 527240 & 527856 water manifold gaskets. 537354 fuel pump gasket. **\$15.50/set**
- 801107** Kit. 1939-54 Champion 6-cylinder. Includes: 194484 front plate gasket, 194219 timing cover gasket & 197591 front crankshaft seal. **\$17.50/set**
- 801213** Kit. 1936-60 Commander 6-cylinder. Includes 186668 cover gasket, 523145 front plate gasket, 167156 front crankshaft washer seal. **\$17.50/set**
- 1561166** Cover gasket. 1951-64 V-8. **\$6.75 ea.**
- 1561172** Cover gasket. 1955-64 Champion 6-cylinder. **\$6.75 ea.**
- NEW Listing - 1564054** Timing cover oil. 1965 - 1966 V-8. **\$2.50 ea.**
- NEW Listing - 1564055** Timing cover. 1965 - 1966 6-cylinder. **\$1.50 ea.**
- NEW Listing - 1564219** Timing cover. 1965 - 66 V-8. **\$1.50 ea.**



SILICONE GASKET SEALER

800944 Forms a permanent non-hardening seal. 3 oz. tube. **\$5.25 ea.**

CRANKSHAFT SHIMS

-
- 186693** .003 shim. 1936-60 Commander 6-cyl. & 1951-64 V-8. **\$3.00 ea.**
- 186694** .005 shim. 1936-60 Commander 6-cylinder & 1951-64 V-8. **\$3.00 ea.**
- 186695** .009 shim. 1936-60 Commander 6-cylinder & 1951-64 V-8. **\$3.00 ea.**
- 537219** .003 shim. 1955-64 Champion 6-cyl. **\$2.25 ea.**
- 537220** .005 shim. 1955-64 Champion 6-cylinder. **\$2.25 ea.**
- 537221** .007 shim. 1955-64 Champion 6-cylinder. **\$2.25 ea.**

CRANKSHAFT FRONT SEAL RETAINER

534542 Front seal retainer. 1951-64 V-8. **\$4.50 ea.**

TIMING COVERS (NEW)



- 191047** 1938-50 Commander. Truck: 1938-5E with Commander 6. **\$39.00 ea.**
- 518495** 1947-55 Champion. **\$31.00 ea.**
- 527121** 1951-54 V-8. **\$32.00 ea.**
- 534440** 1955-64 6-cylinder. Truck: E-8E with Champion 6-cylinder. **\$34.00 ea.**
- 1564052** 1965-66 190 6-cylinder. **\$32.50 ea.**
- 1564217** 1965 V-8. **\$32.50 ea.**
- 1565705** 1966 230 6-cylinder. **\$39.00 ea.**
- 1565706** 1966 V-8. **\$42.00 ea.**

CRANKSHAFT VIBRATION DAMPERS

-
- 186688** 1934-60 car and truck with Commander 6-cylinder. **\$22.50 ea.**
- 519387** 1947-58 Champion. 1959-64 6-cylinder. **\$27.00 ea.**
- 533128** Vibration damper. 1951-64 V-8 except Avanti. Used. **\$35.00 ea.**
- 1558279** 1963-64 Lark & Hawk, jet thrust engine. **\$225.00 ea.**
- 1554247** 1963-64 Avanti jet thrust engine. Pictured. **\$195.00 ea.**

CRANKSHAFT

REINFORCER PLATE

186702 Front reinforcer plate. 1936-60 all with Commander 6-cylinder engine, 1942-64 all with Champion 6-cylinder engine, 1951-64 all with V-8 engine. Truck: early 1962. **\$6.00 ea.**

CRANKSHAFT DAMPER CUSHION

-
- 186703-4** 1936-60 Commander 6-cylinder, 1942-64 Champion 6-cylinder. 1951-64 V-8 except Avanti. **\$12.50 pr.**

CRANKSHAFT LOCK PLATE

-
- 182064** 6-cylinder 1935-37 Dictator & 1938-1960 Commander. Limited supply. **\$12.00 ea.**
- 515202** Lock plate. Keeps front crankshaft bolt from loosening. 1951-64 Champion 6-cyl. & V-8. **\$8.50 ea.**

CAMSHAFTS



- 524882** 1947-60 Champion with 6-cylinder. (Pictured, above) **\$160.00 ea.**
1549471 1961-64 OHV with 6-cylinder before SN312. **\$120.00 ea.**



CAMSHAFT TIMING GEARS

- 181233** 1929-33 Commander & Dictator 8, All 1934-42 V-8 **\$135.00 ea.**

- 532125X** Aluminum. 1939-54 Champion 6-cylinder. **\$160.00 ea.**
532128X Aluminum. 1935-60 Commander 6-cylinder. **\$160.00 ea.**
1554447 1955-64 6-cylinder. Substitute for 534717. **\$75.00 ea.**
1554448 1951-64 V-8 except HD truck & 1963-64 Avanti. **\$130.00 ea.**
NEW Listing - 1564099 1965 - 66 6-cylinder. NOS. **\$45.00 ea.**
1685777 Aluminum. V-8 with Avanti jet thrust engine. Truck: many models with heavy duty equipment. **\$140.00 ea.**

CAMSHAFT REAR HOLE PLUGS

- 194665** 1939-58 Champion. Truck: M5, 10, 15 & 2R-8E 1, 5, 10, 15. Steel. 1-3/4" shallow cup. .. **\$1.50 ea.**
1539038 1951-early 62 V-8 car, all models. Truck: 2R-6E 7, 12, 13, 28, 38, 40. Brass. 1-1/2" disc. **\$3.00 ea.**
1550386 Late 1962-64 V-8 & 1963-64 Avanti. Truck: 7E-8E 7, 12, 13, 28, 38 (brass) 1-1/2" shallow cup. **\$3.50 ea.**
1550434 1959-64 6-cylinder car, all models. Truck: 3E-8E 1, 5, 10. Steel. 1-3/4" shallow cup. **\$1.00 ea.**
NEW Listing - 1563963 1965 - 66 all. Steel. NOS. **\$1.00 ea.**

PAL NUTS For connecting rod bolts.

- G107828** Pal nut V-8. **25¢ ea.**
G441272 Pal nut 1939-64 Champion 6-cylinder. **35¢ ea.**

CONNECTING RODS

* Due to a shortage of NOS rods, these rods require yours in exchange first.

- 517921** Odd # cylinders for 1939-64 Champion 6-cylinder with insert-type bearings. No exchange necessary. **\$45.00 ea.**
517922 Even # cylinders for 1939-64 Champion 6-cylinder with insert-type bearings. No exchange necessary. **\$45.00 ea.**

Odd # cylinders for 1936-42 Dictator & Commander 6-cylinder with insert-type bearings with tapered piston pin clamp screw. Also all 1947-48 Commanders.

- *517925** NOS - exchange. **\$65.00 Ex.**
***517925X** Reconditioned - exchange. **\$45.00 Ex.**

Even # cylinders for 1936-42 Dictator & Commander 6-cylinder with insert-type bearings & with tapered piston pin clamp screw. Also all 1947-48 Commander.

- *517926** NOS - exchange. **\$65.00 Ex.**
***517926X** Reconditioned - exchanged. **\$45.00 Ex.**

Odd # cylinders for 1936-42 Dictator & Commander 6-cylinder with insert-type bearings. The type with hex head piston clamp screw.

- *520145** NOS - exchange. **\$65.00 Ex.**
***520145X** Reconditioned - exchange. **\$45.00 Ex.**

CAM BEARINGS

- 526223** All Commander 6-cylinder, 1932 Rockne, Dictator 6. **\$80.00/set**
526224 1939-60 Champion 6-cylinder. **\$68.00/set**
529459 1951-64 V-8 & 1963-64 Avanti **\$75.00/set**
1550620 1961-early 1962 6-cylinder without full-flow oil filter. **\$48.00/set**
1556138 Late 1962-64 6-cylinder with full-flow oil filter. **\$51.00/set**
NEW Listing - 1564386 Front & rear. 1965 - 66 6-cylinder. Takes 2. NOS. **\$3.00 ea.**
NEW Listing - 1564387 Intermediate. 1965 - 66 6-cylinder. Takes 2 NOS. **\$3.00 ea.**
NEW Listing - 1564521 Front. 1965 - 66 V-8. Takes 1. NOS. **\$3.00 ea.**
NEW Listing - 1564522 Front intermediate & rear. 1965 - 66 V-8. Takes 2. NOS. **\$3.00 ea.**
1564526 Center & rear. 1965 - 66 V-8. Takes 2. NOS. No Stock



CONNECTING ROD BOLT

- NEW Listing - 196567** 1939-64 Champion 6-cylinder. **\$10.00 ea.**

CRANKSHAFT PILOT BUSHING

- 194348** 1939-64 Champion 6-cylinder. Truck: M5, 15, 15A & 2R-2E 5, 10, 15 & 3E-6E 1, 5, 10 & 7E 5, 10. **\$3.50 ea.**
510168 1934-37 Dictator & 1937-39 Coupe Express & 1938-50 Commander & 1951-64 V-8 car & 1963-64 Avanti. Truck: M17 & 2R-6E all except 1, 5, 10, 15 & 7E-8E 5, 7, 10, 12, 13, 28. **\$3.50 ea.**



REAR CRANKSHAFT BOLTS

- NEW Listing - 194542** Bolt, to flywheel. Most models with standard trans. .. **\$3.95 ea.**
526851 Bolt to flex plate. All models with automatic transmission. Takes 6. **\$2.75 ea.**
NEW Listing - 1564004 Bolt, flywheel with automatic transmission to crankshaft. 1965 - 66 all. **\$1.00 ea.**

FRONT CRANKSHAFT BOLTS

- 515111** 1942-64 various models. 2 1/16" **\$24.00 ea.**
537522 3". V-8 various models. **\$29.90 ea.**

- NEW Listing - 908051** 11/16" diameter, 16" x 1 1/16". **\$29.50 ea.**
1546041 2 7/16" 6-cylinder & V-8 various models & 1963-64 Avanti. **\$29.90 ea.**
1550392 1 5/8". 1961-63 6-cylinder. **\$29.50 ea.**

- NEW Listing - 1550393** 11/16" diameter, 16" x 2 1/4". **\$29.50 ea.**

NOTE: VARIOUS OTHER LENGTHS AVAILABLE, PLEASE INQUIRE.



- Even # cylinders for 1936-42 Dictator & Commander 6-cylinder with insert-type bearings. The type with hex head piston clamp screw.
***520146** NOS - exchange. **\$65.00 Ex.**
***520146X** Reconditioned - exchange. **\$45.00 Ex.**

- Odd # cylinders for 1949-60 Commander 6-cylinder engines.
***523203** NOS - exchange. **\$65.00 Ex.**
***523203X** Reconditioned - exchange. **\$45.00 Ex.**

- Even # cylinders for 1949-60 Commander 6-cylinder engines. NOS.
***523204** NOS - exchange. **\$65.00 Ex.**
***523204X** Reconditioned - exchange. **\$45.00 Ex.**

- Odd # cylinder, 1951-64 V-8.
***527114** NOS - exchange. **\$75.00 Ex.**
***527114X** Reconditioned - exchange. No stock

- Even # cylinder, 1951-64 V-8.
***527115** NOS - exchange. No stock
***527115X** Reconditioned - exchange. **\$55.00 Ex.**

CRANKSHAFT TIMING GEARS

- 183898** 1935-60 Commander 6-cylinder. **\$80.00 ea.**
194324 1939-54 Champion 6-cylinder. **\$66.15 ea.**
527084 1951-64 V-8, all model car & truck including Avanti. **\$71.40 ea.**
534303 1955-64 Champion 6-cylinder. **\$81.60 ea.**
NEW Listing - 1564094 1965 194 & 230 6-cylinder. **\$15.00 ea.**
NEW Listing - 1565720 1966 194 & 230 6-cylinder. **\$15.00 ea.**



Rod Bearing Sets

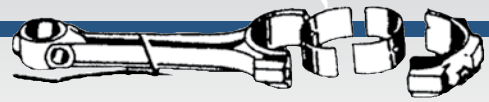

1939-64 CHAMPION 6-CYLINDER

520834	Standard	\$98.00/set
536188	-.002	\$98.00/set
520138	-.005	\$98.00/set
520836	-.010	\$98.00/set
520837	-.020	\$98.00/set
800322	-.030	\$98.00/set
800323	-.040	\$98.00/set
800324	-.060	\$115.00/set

1941-60 COMMANDER 6-CYLINDER

525593	Standard	\$123.25/set
525592	-.001	\$89.00/set
525594	-.005	\$89.00/set
525595	-.010	\$123.25/set
525596	-.020	\$123.25/set

New! MCKINNON
CHEVROLET

1965 - 66 194, 230, 283 V-8 OR 6-CYLINDER

1564350	Standard	\$55.00/set
1564351	.001	\$40.00/set
1564352	.002	\$40.00/set
1564353	.010	\$55.00/set
1564354	.020	\$55.00/set

1951-64 V-8 & 1963-64 AVANTI

1555395	Standard	\$70.00/set
530762	-.001	\$70.00/set
530763	-.002	\$70.00/set
1555398	-.010	\$70.00/set
1555399	-.020	\$70.00/set
800325	-.030	\$70.00/set

Main Bearing Sets

1939-54 CHAMPION 6-CYLINDER

517900	Standard	\$176.00/set
520827	-.001	\$99.00/set
517901	-.010	\$176.00/set
517902	-.020	\$176.00/set
517903	-.030	\$176.00/set
800784	-.040	\$176.00/set
800785	-.060	\$176.00/set

1955-64 CHAMPION 6-CYLINDER

1556295	Standard	\$176.00/set
1556296	-.001	\$99.95/set
1556297	-.002	\$99.95/set
1556298	-.010	\$176.00/set
1556299	-.020	\$176.00/set
1556300	-.030	\$176.00/set

FOR MAIN BEARING SIZES NOT LISTED
PLEASE CALL (317) 462-3124
AND INQUIRE.

1936-48 COMMANDER 6-CYLINDER

517904	Standard	\$176.00/set
520828	-.001	\$132.00/set
517905	-.010	\$196.00/set
517906	-.020	\$255.00/set

1949-60 COMMANDER 6-CYLINDER

524142	Standard	\$142.00/set
524143	-.001	\$99.00/set
524144	-.010	\$198.00/set
524145	-.020	\$198.00/set

1951-64 V-8 & 1963-64 AVANTI

1555404	Standard	\$95.00/set
1555407	-.010	\$95.00/set
1555408	-.020	\$95.00/set
1555409	-.030	\$95.00/set

MCKINNON CHEVROLET **New!**

1965 - 66 194, 230, 6-CYLINDER Front & Center

1564420	Standard	\$35.00/set
1564421	.001	\$35.00/set
1564423	.010	\$35.00/set
1564424	.020	\$35.00/set

1965 - 66 194, 230 6-CYLINDER Rear

1564454	Standard	\$45.00/set
1564455	.001	\$45.00/set
1564456	.002	\$45.00/set
1564457	.010	\$45.00/set
1564425	.020	\$45.00/set

1965 - 66 283 V-8

Rear crankshaft

1564356	Standard	\$15.00/set
1564357	.001	\$15.00/set
1564358	.002	\$15.00/set
1564359	.010	\$15.00/set
1564360	.020	\$15.00/set

1965 - 66 283 V-8

Front & center

1564374	Standard	\$15.00/set
1564375	.001	\$15.00/set
1564376	.002	\$15.00/set
1564377	.010	\$15.00/set
1564378	.020	\$15.00/set

REAR MAIN BEARING SEALS

NEW Listing -

525945	Car: 1948 Commander. Truck: Late M16-17, early 2R16 - 2R17, all with 226 cubic inch engine.....	\$45.00 ea.
1540603	1949-50 Commander. Truck: 1949-60 2R-5E 3, 6, 11,14, 16, 17 with Commander 6-cylinder engine.....	\$50.10 ea.
1540604	1948-54 Champion 6-cyl.....	\$55.00 ea.
1554698	1955-64 Champion 6-cyl.....	\$30.00/set
1559366	1951-64 V-8 & 1963-64 Avanti.....	\$39.75/set



MCKINNON CHEVROLET MAIN BEARING CAPS

New!

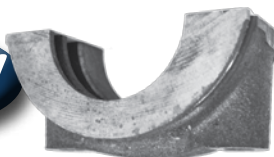

NEW Listing - 1564413	Main bearing cap, rear. 1965 - 66 6-cylinder....	\$20.00 ea.
NEW Listing - 1564446	Main bearing cap, front & center. 1965 - 66 all.....	\$20.00 ea.
NEW Listing - 1564855	Main bearing cap, rear. 1965 - 66 V-8.....	\$20.00 ea.

PISTON PINCH BOLTS

197299	6-cylinder, 1938-50 Commander 1938-42 use two types, check before ordering) and 1939-64 6-cylinder Champion.	\$9.80 ea.
529348	1951-64 V-8 & 1963-64 Avanti.....	\$6.00 ea.

Piston Sets



1939-58 CHAMPION 6-CYLINDER

524383	Standard.....	\$186.00/set 6
534946	+010.....	\$186.00/set 6
534948	+020.....	\$186.00/set 6
534949	+030.....	\$186.00/set 6
534999	+040.....	\$186.00/set 6
800318	+060.....	\$186.00/set 6

1947-60 COMMANDER 6-CYLINDER

524315	+Standard.....	\$475.00/set 6
524311	+020.....	\$475.00/set 6
524312	+030.....	\$475.00/set 6
522119	+040.....	\$475.00/set 6
800320	+060.....	\$475.00/set 6

1959-63 CHAMPION 6-CYLINDER

1547116	Standard.....	\$398.00/set 6
1547560	+020.....	\$398.00/set 6
1547561	+030.....	\$398.00/set 6
1547562	+040.....	\$398.00/set 6
800319	+060.....	\$398.00/set 6

Piston Ring Sets

1939-63 CHAMPION 6-CYL. Cast iron

518102	Standard.....	\$80.50/set
518103	+020.....	\$80.50/set
518104	+030.....	\$80.50/set
522695	+040.....	\$80.50/set
800329	+060.....	\$80.50/set

1964 6-CYL. Cast iron

1561352	Standard.....	\$80.50/set
1561354	+020.....	\$80.50/set
1561355	+030.....	\$80.50/set
1561356	+040.....	\$80.50/set

1938-60 COMMANDER 6-CYL. Cast iron

518114	Standard.....	\$72.50/set
518115	+020.....	\$72.50/set
518116	+030.....	\$72.50/set
522702	+040.....	\$72.50/set
800330	+060.....	\$72.50/set

1951-54 232, V-8 Cast iron

530975	Standard.....	\$95.00/set
530976	+020.....	\$95.00/set
530977	+030.....	\$95.00/set
530978	+040.....	\$95.00/set
800777	+060.....	\$95.00/set

1955-64 259 V-8

1539556	Standard.....	\$259.00/set 8
1553159	+001.....	\$259.00/set 8
1553160	+002.....	\$259.00/set 8
1553565	+010.....	\$259.00/set 8
1539567	+030.....	\$259.00/set 8
1539568	+040.....	\$259.00/set 8
800321	+060.....	\$259.00/set 8

1956-64 289 V-8

1558978	+020.....	\$259.00/set 8
1558979	+030.....	\$259.00/set 8
1558980	+040.....	\$259.00/set 8
800315	+060.....	\$259.00/set 8
801553	+080.....	\$259.00/set 8

1963-64 289 AVANTI JET THRUST R-1 OR R-2

1557856	+010.....	\$259.00/set 8
1557857	+020.....	\$259.00/set 8
1557858	+030.....	\$259.00/set 8
1557859	+040.....	\$259.00/set 8
800280	+060.....	\$259.00/set 8
801554	+080.....	\$259.00/set 8

1955-64 (Including Avanti) 224, 259 & 289 V-8 Cast iron

536252	Standard.....	\$60.50/set
536253	+020.....	\$60.50/set
536254	+030.....	\$60.50/set
536255	+040.....	\$60.50/set
800223	+060.....	\$60.50/set
802295	+080.....	\$60.50/set

1955-64 (Including Avanti) 224, 259 & 289 V-8 (Chrome)

801365	Standard.....	\$80.50/set
800957	+020.....	\$80.50/set
800958	+030.....	\$80.50/set
800959	+040.....	\$80.50/set
800960	+060.....	\$80.50/set
802110	+080.....	\$88.50/set

McKINNON CHEVROLET 1965 - 66 194 6-CYL.

(Original type)

1564416	Standard.....	\$45.00/set
1564417	.020.....	\$45.00/set
1564418	.030.....	\$45.00/set

McKINNON CHEVROLET 1965 - 66 194 6-CYL.

(High Mileage)

1564415	Standard.....	\$45.00/set
1564414	.020.....	\$45.00/set
1564452	.040.....	\$45.00/set

McKINNON CHEVROLET

New!

1965 - 66 194 6-CYL.

Original type

1564474	Standard.....	\$100.00/set
1564480	.020.....	\$100.00/set
1564482	.030.....	\$100.00/set
1564484	.040.....	\$100.00/set

1965 - 66 194 6-CYL.

High Limits

1564476	Standard.....	\$100.00/set
---------	---------------	--------------

AS ALWAYS, IF YOU DON'T SEE WHAT
YOU NEED, PLEASE CALL
(317) 462-3124 & INQUIRE.

McKINNON CHEVROLET PISTON RING SETS

1965 - 66 283 V-8

Production type

1564371	Standard.....	\$35.00/set
1564372	.020.....	\$35.00/set
1564373	.030.....	\$35.00/set

1965 - 66 283 V-8

High Mileage

1564381	Standard.....	\$35.00/set
1564382	.020.....	\$35.00/set
1564383	.030.....	\$35.00/set
1564384	.040.....	\$35.00/set

1965 - 66 283 V-8

Perfect Circle

1565042	Standard.....	\$35.00/set
1565043	.020.....	\$35.00/set
1565044	.030.....	\$35.00/set

1965 - 66 194 6-CYL.

(Sealed Power)

1565073	Standard.....	\$35.00/set
1565074	.020.....	\$35.00/set
1565075	.030.....	\$35.00/set
1565076	.040.....	\$35.00/set

1965 - 66 283 V-8

Sealed Power

1565099	Standard.....	\$35.00/set
1565100	.020.....	\$35.00/set
1565101	.030.....	\$35.00/set
1565102	.040.....	\$35.00/set

1965 - 66 230 6-CYL.

Sealed Power - high mileage

1565757	Standard.....	\$35.00/set
1565760	.040.....	\$35.00/set

NOTE: CHROME RINGS ARE ALSO
AVAILABLE FOR 6-CYLINDER AND EARLY V-8.
PLEASE INQUIRE!

OIL PUMP TO BODY GASKETS

172622 Oil pump body cover gasket. 1934-49 Commander. Truck: 1934-49 with Commander 6-cyl. engine. **\$2.00 ea.**

195304 Oil pump body gasket. 1939-60 Champion 6-cyl. . **\$2.00 ea.**

510193 Oil pump body gasket. 1934-50 Commander. Truck: 1934-60 with Commander 6-cyl. engine. **\$2.00 ea.**

521371 Oil pump body cover gasket. 1939-60 Champion 6-cylinder. **\$2.00 ea.**

526203 Oil pump body cover gasket. 1950 Commander. Truck: 1950-60 with Commander 6-cylinder engine. **\$2.00 ea.**

527224 Oil pump gasket. 1951-64 V-8 & 1963-64 Avanti. **1.00 ea.**

535697 Oil filler tube gasket. 1955-64 V-8 & 1963-64 Avanti **\$1.00 ea.**

1543376 Oil pump body gasket. 1961-64 6-cylinder..... **\$2.00 ea.**

1555103 Oil filter base to block gasket. Late 1962-64 all models & 1963-64 Avanti. **\$2.00 ea.**

1557705 Oil tube breather to pan gasket. 1963-64 Avanti jet thrust V-8. **\$1.00 ea.**

NEW Listing - 1564861 Cover gasket, oil pump. 1965-66 V-8. **\$1.00 ea.**

OIL PUMP STRAINERS

187333 1939 - early 1957 Champion 6-cylinder. 1936-42 All cars except President 1938-42 President. Does not include tube..... **\$65.00 ea.**

532968 1953-54 V-8. **\$35.00 ea.**

535784 1955 V-8. Pictured. **\$35.00 ea.**

1541778 Late 1957-64 Champion 6-cylinder. Includes tube. **\$35.00 ea.**

1564204 1965-66 V-8. **\$20.00 ea.**

1564870 1965-66 6-cylinder. .. **\$20.00 ea.**

OIL ADDITIVE

801847 ZDDPlus avoid metal to metal wear on your engine. ZDDPlus After 70+ years of trouble-free, metal-to-metal engine protection, the EPA is forcing ZDDP (Zinc Dialkyl Dithio Phosphate +zinc and phosphorus) from domestic motor oils. If your engine was designed prior to the the 1990's the non-roller lifters require the ZDDP in the motor oil to avoid premature deterioration! Don't let the lifters run metal-to-metal. Keep ZDDP, via ZDDPlus to every 4- to 5- quart oil change. **\$9.95 ea.**

801847X10 Case of 10 ZDDP. **\$80.00 ea.**



OIL PUMP REBUILD KITS & RELATED PARTS

517894 Oil pump & distributor drive gear. 11 teeth. 1947-60 Commander. **\$36.00 ea.**

522072 Cover, oil pump kit. 1939-46 Champion, 1955-60 Champion. For pump with 1.5" tall gears. **\$12.50 ea.**

800039 1956-64 V-8 car & truck & 1963-64 Avanti. Kit includes gears, shaft & cover plate. Pictured. **\$102.00/set**

800743 1951-55 V-8. Kit includes gears & shaft. **\$105.00 ea.**

800745 Major rebuild kit. 1939-60 Champion 6-cylinder. Includes both gears, 1/2" drive shaft with gear, thrust washer & gaskets. **\$108.00 ea.**

801347 Major rebuild kit for 1948-60 Commander 6-cylinder. Includes 3 gears, thrust washer, key & gaskets. **\$95.00 ea.**

801464 Rebuild kit. 1961-64 OHV 6-cylinder. **\$85.00 ea.**

1539479 Cover, oil pump. 1956-64 V-8. **\$15.00 ea.**

SPECIAL OIL PRESSURE RELIEF VALVE KIT

Kit includes:

- 536670 spring
- 192136 valve
- 192125 washer



1939-64 Champion 6-cyl. 1951-64 V-8 car & truck & 1963-64 Avanti. Reg. price. . \$18.50 ea.

801172 Kit Price **\$16.50 ea.**

OIL PRESSURE RELIEF VALVES & SPRINGS

182075 Spring, 1934-60 Car & truck with Commander 6-cylinder. **\$5.00 ea.**

182076 Valve. 1934-60 Commander 6-cyl. **\$8.00 ea.**

192125 Washer. 1939-64 Champion 6-cyl. car & truck, 1951-64 V-8 & 1963-64 Avanti. **\$1.50 ea.**

192136 Valve. 1939-64 Champion 6-cyl. car & truck, 1951-64 V-8 & 1963-64 Avanti. **\$12.00 ea.**

536670 Spring. 1939-64 Champion 6-cyl. 1951-64 V-8 car & truck & 1963-64 Avanti. **\$5.00 ea.**

G113897 Compression gasket. 1934-60 Commander 6-cylinder. **\$1.50 ea.**

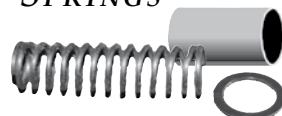

OIL PAN

NEW Listing - 525099 Oil pan. 1950 Champion. **\$130.00 ea.**

NEW Listing - 1564863 Oil pan. 1965-66 Commander 6 V-8. **\$85.00 ea.**

NEW Listing - 1565723 Oil pan. 1966 6-cylinder. **\$75.00 ea.**

1691084 Truck: 4E -5E 3, 6, 11, 14, 16. Pictured, above. **\$127.50 ea.**

NOTE: OTHERS IN STOCK - PLEASE INQUIRE.



OIL DRAIN PLUGS

3080X2 1959-64 all models 6-cylinder & V-8 & 1963-64 Avanti. Includes gasket. **\$3.50 ea.**

510080 1928-58 all models. Includes gasket. **\$4.00 ea.**

801171 Oversized & self tapping. Replaces 510080 for 1928-58 all models. Includes gasket. **\$5.50 ea.**

G113897 Gasket. 1932-33 Rockne, 1928-58 Studebaker. **\$1.50 ea.**

1564336 Gasket. 1965-66 all. **\$1.00 ea.**

OIL PAN GASKET SETS



S-346 1939-54 Champion 6-cylinder. **\$11.00 ea.**

186710 1936-60 Commander 6-cylinder. **\$16.75 ea.**

1561429 1955-64 Champion 6-cylinder. **\$11.00 ea.**

1561465 1951-64 V-8 & 1963-64 Avanti. **\$10.50 set**

McKINNON CHEVROLET GASKETS & SEALS FOR ALL 1965 - 66 CAR

NEW Listing - 1564026 Front oil pan. 1965-66 6-cylinder. **\$1.00 ea.**

NEW Listing - 1564027 Rear oil pan. 1965-66 6-cylinder. **\$1.00 ea.**

NEW Listing - 1564187 Front oil pan. 1965-66 V-8. **\$1.00 ea.**

NEW Listing - 1564188 Rear oil pan. 1965-66 V-8. **\$1.00 ea.**

NEW Listing - 1564419 Rear main oil. 1965-66 6-cylinder. **\$4.00 ea.**

NEW Listing - 1565168 Rear main oil. 1965-66 V-8. **\$5.00 ea.**

OIL SLINGERS Crankshaft

189316 Oil slinger. 1951-64 V-8 & 1963-64 Avanti. .. **\$12.90 ea.**

197592 Oil slinger. 1939-64 with Champion 6-cylinder. **\$4.00 ea.**



OIL BREATHER CAPS



- 177034** 1935 Studebaker Six, 1934-42 Dictator, Commander 6 & 8's and Coupe Express, also President 8 through 1942. **\$24.00 ea.**
- 1558194** Chrome oil breather cap with blue and white STP decal. Just like the original. 1963-64 Avanti, Lark, Hawk with jet thrust engine. Will also fit all 1962-64 V-8 with oil breather caps on rocker covers. ... **\$30.00 ea.**
- NEW Listing - 1558580** Orange oil breather cap with blue and white STP decal. Just like the original. Late 1962 - 64 V-8. Takes 2. **\$30.00 ea.**
- NEW Listing - 1564703** 1965-66 6-cylinder. Not vented. **\$12.50 ea.**
- NEW Listing - 1564704** 1965-66 V-8. Not vented. **\$12.50 ea.**

OIL FILTERS



- 196646** F-4 cartridge filter. 1938-62. 4 1/4" diameter. **\$12.40 ea.**
- 197482** F-3 cartridge filter. 1939-56. 3 3/4" diameter. **\$10.60 ea.**
- 800481** 1965-66 6-cyl. 1969-84 Avanti. **\$8.85 ea.**

AC-3300 Replacement spin-on filter above engine. 1957-62 6-cyl. & V-8. **\$9.50 ea.**

AC-3300X1 NOS Studebaker logo. 1959- early 62. **\$25.00 ea.**



AC-3311 Replacement spin-on filter below engine. Late 1962-64 6-cyl. & V-8 all models & 1963-64 Avanti. **\$12.50 ea.**

SP-50057 Cartridge. 1956 Golden Hawk. NOS. **\$16.50 ea.**

1564488 1960-65 6-Cylinder. NOS with original lettering. Pictured. **\$25.00 ea.**

OIL FILTER BASES



1555325 Oil filter base. 1957-early 1962. **\$24.00 ea.**

1555680 Oil filter cover plate on block. All 1962-64 V-8 with full flow oil filter. . **\$8.50 ea.**

1555771 Oil filter base. Late 1962-64 6-cyl. & V-8 & 1963-64 Avanti. **\$49.00 ea.**

OIL FILLER TUBES

195428 1939-50 Commander. Truck: M-16, 17, 2R - 5E with Commander 6-cylinder engine. **\$25.00 ea.**

525922 1950-60 Champion 6-cylinder. **\$25.00 ea.**

531650 1951-54 V-8. **\$25.00 ea.**

1539054 1955-60 V-8. **\$25.00 ea.**

1551495 1961-62 V-8. **\$25.00 ea.**

NEW Listing - 1564208 1965-66 V-8 without sealed PCV. **\$25.00 ea.**

1564705 1965-66 V-8 with sealed PCV. **\$25.00 ea.**

OIL PUMP

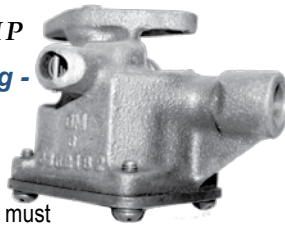

- NEW Listing - 1539412** Oil pump. 1956-64 V-8. Rebuilt -exchange. (We must receive your rebuildable pump before this item ships. **225.00 Ex.**
- NEW Listing - 1564031** Oil pump. 1965 -66 6-cylinder. **\$145.00 ea.**

OIL BREATHER

- NEW Listing - 1564733** Adapter, oil breather without sealed PCV. 1965 - 66 V-8. **\$5.00 ea.**

FLEXIBLE HOSES

Attaches to Oil Gauge & Engine Block

NOTE: AGE, HEAT & DETERIORATION OFTEN CAUSE THIS HOSE TO FRACTURE, RESULTING IN OIL LOSS AND ENGINE FAILURE. CHECK & REPLACE FREQUENTLY!



- 530096** 1951-66 V-8 car & truck & 1963-64 Avanti, all models with oil pressure gauge. **\$12.95 ea.**
- 532339** Replacement less bracket. 1939-63 Champion. 1934-40 also 1947-50 Commanders & 1934-50 Presidents. **\$18.00 ea.**
- 1562365** 1965-66 6-cyl. **\$18.50 ea.**

ENGINE OIL DIPSTICKS & RELATED PARTS



- 519408** 1947-49 Champion with cap. **\$40.00 ea.**
- 520225** Dipstick. 1947-48 Commander. **\$19.50 ea.**
- 523184** 1949 Commander. **\$19.50 ea.**
- 525331** Dipstick. 1950 Commander. **\$19.50 ea.**
- 525645** 1950 Commander. For models with extension tube. **\$19.50 ea.**
- 526411** Dipstick. 1951-54 Champion. **\$19.50 ea.**

530995 Dipstick. 1951-52 Commander. **\$19.50 ea.**

533185 Dipstick. 1953-54 Commander C & K. **\$19.50 ea.**

533209 Dipstick. 1953-54 Commander sedan. **\$19.50 ea.**

534727 Dipstick. 1956-57 6-cyl. **\$19.50 ea.**

680204 Cap & Dipstick, Truck: 2R-3R, 5, 10, 15. **\$32.50 ea.**

1539890 Dipstick. 1956-64 V-8. **\$28.50 ea.**

1544477 Dipstick. 1958-64 6-cyl. **\$19.50 ea.**

1558331 Dipstick. 1956-64 V-8 car & truck, 1963-64 Avanti. NOS with new chrome plating. **\$39.95 ea.**

1563473 Dipstick. All 1965- early 68 V-8 with power or disc brakes. **\$16.00 ea.**

1563937 Dipstick. All 1965- early 66 V-8 without power brakes or disc brakes. Also late 1966 V-8. **\$10.00 ea.**

1564485 Dipstick. All 6-cylinder 1965 and early 66 194 & 230 cubic inch. **\$16.00 ea.**

1565764 Dipstick. Late 194 & 230 6-cylinder. **\$16.00 ea.**

OIL FILTER FLEXIBLE

- HOSES** Length measurement is in inches.
- 515710** Inlet, 28 1/4" length. 1947-50 Champion. **\$22.50 ea.**
- 521902** Inlet, 31" length. 1951-54 6-cylinder with cartridge type filter. **\$22.50 ea.**
- 525927** Outlet, 8 1/8" length. 1947-54 6-cylinder with cartridge type filter. **\$22.50 ea.**
- 525927** Outlet, 8 1/8" length. 1956-58 6-cylinder with cartridge type filter. **\$22.50 ea.**
- 527309** Inlet, 37.39 CE 37" length. 1937-48 Commander. **\$ 38.50 ea.**
- 532565** Inlet, 9" length. For spin-on type filter and 1957-58 V-8, 1959-60 cars with A/C & 1959-60 cars with dealer installed filter V-8, only. **\$22.50 ea.**
- 532565** Outlet, 9" length. Cartridge type filters on 1955-58 V-8 & 1959-60 V-8 without A/C and with factory installed filter. **\$22.50 ea.**
- 536792** Inlet, 10 7/8" length. 1955-57 V-8 & 1959-60 V-8 with factory installed cartridge type filter. **\$22.50 ea.**
- 1542745** Outlet, 22 1/4" length. 1957-58 6-cylinder with spin on type filter. **\$38.90 ea.**
- 1548287** Outlet, 17 7/8" length. 1959 6-cylinder with spin on type filter. **\$22.50 ea.**
- 1548288** Inlet, 17 3/8" length. 1959-60 6-cylinder with spin-on type filter. **\$22.50 ea.**
- 1551563** Inlet. 1961-62 6-cylinder with spin on type filter. Also, 1961-62 V-8 with cartridge type filter. **\$22.50 ea.**
- 1551564** Outlet, 15" length. 1961-62 6-cylinder with spin-on filter. **\$22.50 ea.**
- 1551993** Inlet or outlet, 8". 1961-62 V-8 with spin-on filters. **\$22.50 ea.**
- 1551994** 19 3/8" length, inlet. 1961-62 6-cylinder with cartridge type filter. **\$22.50 ea.**

NOTE: MANY CARS HAVE HAD SUBSTITUTED HOSES INSTALLED. FOR BEST RESULTS, MEASURE WHAT YOU NEED & ORDER FROM THE ABOVE LIST.

OIL FLEX TUBE BRASS ELBOW

199218 Brass elbow, cylinder head to oil flex tube. Oil line to gauge. 1963-64 Avanti. **\$3.50 ea.**

OIL STRAINER TUBES

- 524964** 1950 Champion. **\$18.50 ea.**
- 525053** 1950 Commander. **\$18.50 ea.**
- 529267** 1951-54 V-8. **\$18.50 ea.**

DIPSTICK TUBE

- 530994** 1951-52 Commander. 1953-55 C & K. **\$20.50 ea.**
- 533221** Upper. 1953-54 V-8 & 1955 except C & K. **\$15.00 ea.**
- 1539871** Upper. 1956-58 V-8. **\$15.00 ea.**
- 1544476** 1958-59 6-cylinder with standard & overdrive transmissions, late 1959 with automatic transmission and all 1960 6-cylinder. **\$15.00 ea.**
- 1545283** 1958-early 59 w/auto transmission. **\$15.00 ea.**
- 1557692** Upper chrome, 1963-64 Lark & Hawk & 1963-64 Avanti with jet thrust engine, chrome. **\$32.00 ea.**

INTAKE & EXHAUST VALVES



- 187171** Intake. 1932-33 Rockne. 1934-60 Dictator & Commander 6-cylinder. NOS. **\$23.10 ea.**
- 189820** Exhaust. 1932-33 Rockne. 1934-60 Dictator & Commander 6-cyl, 1932-42 Straight-8's. **\$26.00 ea.**
- 194216** Intake. 1939-60 Champion, 6-cylinder. Stainless. **\$25.00 ea.**
- 194217** Exhaust. 1939-60 Champion, 6-cylinder Stainless. NOS. **\$25.00 ea.**
- 440664** Exhaust. Standard 1956 Golden Hawk. NOS. **\$25.00 ea.**
- 527693** Exhaust. 1951-54 V-8. NOS. **\$20.00 ea.**
- 527694** Intake. 1951-54 V-8. NOS. **\$16.00 ea.**
- 535939** Exhaust, standard duty. 1955-64 V-8. NOS. **\$9.00 ea.**
- 680697** Intake. Commander 6-cylinder with rotary cap. **\$18.00 ea.**
- 683875** Exhaust, stainless. Standard, 1955-64 V-8. Avanti R-1, R-2, heavy duty. **\$15.50 ea.**
- 683876** Intake, stainless. 1955-64 V-8. **\$14.50 ea.**
- 800534** Exhaust, stainless. Avanti R-3, R-4. **\$135.00/set 8**
- 800535** Intake, stainless. Avanti R-3, R-4. **\$135.00/set 8**
- 1550591** Intake. 1961-64 6-cylinder. **\$15.00 ea.**
- 1550592** Exhaust. 1961-64 6-cylinder. **\$23.00 ea.**
- NEW Listing - 1563982** Intake, standard. All 1965 - 66. NOS. **\$5.00 ea.**
- NEW Listing - 1564157** Exhaust, standard. 1965 6-cylinder & 8-cylinder. NOS. **\$5.00 ea.**
- NEW Listing - 1564362** Exhaust. .003 1965 6-cylinder & V-8. NOS. **\$5.00 ea**
- NEW Listing - 1564363** Exhaust, .015 1965 6-cylinder & V-8. NOS. **\$5.00 ea**
- NEW Listing - 1564364** Exhaust, .030 1965 6-cylinder & V-8. NOS. **\$5.00 ea**
- NEW Listing - 1564396** Intake, .003 all 1965 - 66 6-cylinder & V-8. NOS. **\$5.00 ea**
- NEW Listing - 1564397** Intake, .015 all 1965 - 66 6-cylinder & V-8. NOS. **\$5.00 ea**
- NEW Listing - 1564398** Intake, .030 all 1965 - 66 6-cylinder & V-8. NOS. **\$5.00 ea**
- 1565711** Exhaust, standard. 1966 6-cylinder & V-8. NOS. **\$5.00 ea.**
- NEW Listing - 1565712** Exhaust, .003 1966 6-cylinder & V-8. NOS. **\$5.00 ea.**
- NEW Listing - 1565713** Exhaust, .015 1966 6-cylinder & V-8. NOS. **\$5.00 ea.**
- NEW Listing - 1565714** Exhaust, .030 1966 6-cylinder & V-8. NOS. **\$5.00 ea.**
- 6480390** Intake, standard. 1956 GH. **\$26.00 ea.**
- 6480392** Intake, .010 O.S. 1956 GH. **\$26.00 ea.**
- 6480393** Intake, .020 O.S. 1956 GH. **\$26.00 ea.**

VALVE RELATED PARTS

- 168535** Spring damper. 1935-60 Commander 6-cylinder 1951-64 V-8 car & truck & 1963-64 Avanti. 1961-64 OHV 6-cylinder. ... **\$3.00 ea.**
- 174837** Valve retainer clips. 1935-60 Commander 6-cylinder. **\$1.75 pr.**
- 195286** Valve retainer clip. 1939-60 Champion. **\$5.00 ea.**
- NEW Listing - 195616** Lifter spring, 1939-60 Champion 6-cylinder. **\$12.50 ea.**
- 526204** Lifter spring. 1947-60 Commander 6-cylinder. **\$3.80 ea.**



- 527138** Valve lifter cover. 1951-64 V-8. Valley Cover. **\$30.00 ea.**
- 527180** Valve retainer clip. 1951-64 V-8 car & truck & 1963-64 Avanti. 1961-64 OHV 6-cylinder. **\$1.00 pr.**
- 527184** End plug, rocker shaft arm. 1951-64 V-8 car & truck & 1963-64 Avanti. Takes 4. 1961-64 OHV 6-cylinder. Takes 2. **75¢ ea.**
- 527890** Push rod. 1951-early 61 V-8. **\$9.00 ea.**
- 532161** Tappet adjusting screw. 1952-56 V-8. **\$7.30 ea.**
- 532177** Rocker arm. 1952-54 V-8. **\$18.00 ea.**
- 534890** Valve spring cover, rear. 1954-60 6-cylinder Champion. **\$13.50 ea.**



- 534892** Valve spring cover, front. 1954-60 6-cylinder Champion. **\$13.50 ea.**
- 536222** Rocker arm. 1955 -early 1961 V-8. **\$18.00 ea.**

- 682695** Rotator cap. 1955-64 V-8 heavy duty exhaust valve. **\$26.00 ea.**
- 1541806** Rocker adjusting screw. 1957-early 1961 V-8. **\$7.50 ea.**
- 1544591** Spring retainer. 1958-64 V-8 car & truck & 1963-64 Avanti. 1961-64 OHV 6-cylinder. **\$2.00 ea.**
- 1550303** Push rod. Late 1961-64 V-8 car & truck & 1963-64 Avanti. No Stock
- 1550360** Rocker adjusting screw. Late 1961-64 all models car & truck & 1963-64 Avanti. **\$5.30 ea.**
- NEW Listing - 1564103** cover, valve lifter & push rod. 1965 - 66 6 - cylinder. **\$8.00 ea.**
- NEW Listing - 1564106** Arm, valve rocker. 1965 - 66 with 6-cylinder engine. **\$4.00 ea.**
- NEW Listing - 1564260** arm, valve rocker. 1965 - 66 V-8. **\$5.00 ea.**
- NEW Listing - 1564261** ball, valve rocker arm. 1965 - 66 V-8. **\$4.00 ea.**

VALVE SPRING LIFTER COVER GASKETS (Valley cover

- Gasket) 
- 196126** 1935-60 Commander 6-cyl. **\$11.00 pr.**
- 536554** 1939-64 Champion 6-cyl. **\$10.00 pr.**
- 1561169** 1951-64 V-8 & 1963-64 Avanti. **\$10.00 ea.**

VALVE STUD COVER GROMMET



- 530858** 1961-64 6-cyl. & 1951-64 V-8 & 1963-64 Avanti. **\$1.00 ea.**

ROCKER COVER

- NEW Listing - 1550637** Rocker cover, 1961-64 OHV 6-cylinder. **\$38.50 ea.**
- NEW Listing - 1552106** 4-hole rocker cover, 1959-60 V-8. Will also fit 1951-58 V-8. **\$65.00 ea.**
- NEW Listing - 1564496** rocker cover, 1965 - 66 6-cylinder. **\$35.00 ea.**

ROCKER COVER GASKETS

Sets include grommets



- 536555** 1951-early 1960 V-8. Neoprene. Includes 8 stud grommets. **\$24.00 pr.**
- 536555X** 1951-early 1960 V-8. Composition. Includes 8 stud grommets. **\$16.75 pr.**
- 1561165** Late 1960-64 V-8 & 1963-64 Avanti. Neoprene. Includes 4 stud grommets. **\$24.00 pr.**
- 1561165X** Late 1960-64 V-8 & 1963-64 Avanti. Composition. Includes 4 stud grommets. **\$16.75 pr.**
- 1561167** 1961-64 6-cylinder. Neoprene. Grommets are not included. **\$15.00 ea.**

CHROME ROCKER COVER NUTS



- 1-101** Original on 1963-64 Avanti and an attractive addition on others. Set contains 4 chrome acorn nuts and 4 chrome washers. Will fit 1951-64 V-8 & 6-cylinder. **\$12.00/set 4**

V-8 ENGINE DRESS-UP



- 801458** Finned V-8 rocker covers without breather tubes. **\$275.00 pr.**
- 801459** Finned V-8 rocker covers with breather tubes. Caps are not included. **\$285.00 pr.**
- 801460** Finned V-8 Valley cover with hole for breather. **\$140.00 ea.**
- 801461** Finned oil filler block off plate. **\$20.00 ea.**
- 801550** Finned V-8 Valley cover without hole for breather. **\$145.00 ea.**
- NEW Listing - 802291** Finned V-8 valley cover with threaded hole for PC V, 1964. **\$140.00 ea.**

VALVE SEATS

NOTE: THESE PREMIUM GRADE VALVE SEATS ARE SUITABLE FOR USE WITH UNLEADED FUELS.



- 800551** Inlet. 1955-64 V-8 car & truck & 1963-64 Avanti R-1 **\$55.00/set 8**
800552 Exhaust. 1955-64 V-8 car & truck & 1963-64 Avanti R-1 **\$49.50/set 8**
800553 Inlet. V-8 with supercharger & 1963-64 Avanti R-2. **\$66.00/set 8**
800554 Exhaust. V-8 with supercharger & 1963-64 Avanti R-2. **\$64.00/set 8**
800566 Inlet. 1939-60 Champion 6-cylinder. **\$38.00/set 6**
800567 Exhaust. 1939-60 Champion 6-cylinder. **\$38.00/set 6**
800568 Inlet. 1961-64 6-cylinder. **\$58.00/set 6**
800569 Exhaust. 1961-64 6-cylinder. **\$40.00/set 6**
800570 Inlet. 1939-50 Commander 6-cylinder. **\$40.00/set 6**
800571 Exhaust. 1939-50 Commander 6-cylinder. **\$40.00/set 6**
800572 Inlet. 1951-54 V-8. Truck: 3R 28, 38. **\$49.30 set/8**
800573 Exhaust. 1951-54 V-8. **\$55.00/set 8**

VALVE STEM SEALS

- 527191** 1951-54 V-8. **75¢ ea.**
536264 1955-64 V-8 & 1963-64 Avanti & 1961-64 6-cyl **\$1.00 ea.**

VALVE SPRINGS



- 188645** 1936-60 Commander 6-cylinder, 1963-64 Avanti jet thrust V-8. **\$8.00 ea.**
514236 1939-60 Champion 6-cylinder. **\$11.00 ea.**
530418 1936-60 Commander 6-cylinder with rotary cap. **\$8.00 ea.**
533245 1951-64 V-8 except Avanti. 1961-64 OHV 6-cylinder. **\$8.00 ea.**
682708 1954-64 V-8 exhaust with rotary cap. **\$8.50 ea.**
1564871 1965-66 6-cylinder. ... **\$8.00 ea.**



VALVE LIFTERS

- 518407** 1947-48 Commander 6-cylinder. **\$17.50 ea.**
522655 1939-60 Champion 6-cylinder. Pictured. **\$139.00/set 12**
524596 1949-60 Commander 6-cylinder. **\$17.50 ea.**
1549247 1961-64 6-cylinder. 1955-64 V-8 & 1963-64 Avanti. **\$9.40 ea.**

NOTE: SOME OVERSIZE LIFTERS ARE AVAILABLE. PLEASE INQUIRE.

VALVE GUIDES



- 186666** Intake & exhaust. 1939-60 Commander 6-cylinder. **\$142.60/set 12**
194359 Intake & exhaust. 1939-60 Champion 6-cylinder. NOS **\$51.50/set 12**
527088 Intake. 1961-64 6-cylinder. & 1951-64 V-8 & 1963-64 Avanti. **\$6.50 ea.**
530222 Exhaust. 1951-64 V-8 including Avanti. **\$6.50 ea.**
1552301 Exhaust. 1961-64 6-cylinder. **\$45.00/set 6**

VALVE GRIND GASKET SETS

CONTAINS UPPER ENGINE GASKETS & SEALS REQUIRED WHEN REBUILDING CYLINDER HEADS & VALVES.

- 800388** 1961-64 6-cylinder. **\$84.00/set**
800389 1939-60 Champion 6-cylinder. **\$90.00/set**
800390 1938-60 Commander 6-cylinder. **\$72.00/set**
800391* 1961-64 V-8 includes Avanti. Comes with thin head gaskets. . **\$119.00 set**
800975 1951-54 V-8. **\$95.00 set**
802255 Late 1960 V-8. **\$119.00/set**
802256 1955-early 1960 V-8. **\$119.00/set**

HEAT RISER VALVES & PARTS

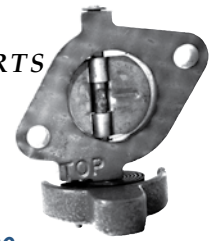

- 179369** Screw, valve to shaft. 1961-64 OHV 6-cylinder. **\$5.25 ea.**
196414 Gasket, heat riser valve. 1939-60 Champion 6-cylinder. **\$5.00 ea.**
196655 Valve & shaft. 1939-60 Champion 6-cylinder. **\$22.50 ea.**
196661 Thermostat. 1939-60 Champion 6-cylinder. **\$12.00 ea.**
196662 Balance weight. 1939-60 Champion 6-cylinder. **\$12.50 ea.**
199140 Screw, balance retainer. 1950-60 Commander 6-cylinder. **\$6.50 ea.**
515821 Valve bushings. 1942-64, 6-cylinder. Truck: M5-8E 6-cylinder. **11.00 ea.**
515835 Balance weight. 1950-60 Commander 6-cylinder. **\$11.25 ea.**
520458 Plug. 1939-60 Champion. **\$5.50 ea.**
525315 Shaft. Late 1950-60 Commander 6-cylinder. **\$18.50 ea.**
525316 Thermostat. Late 1950-60 Commander 6-cylinder. **\$11.00 ea.**
525317 Pin, thermostat anchor. **\$3.00 ea.**
525319 Spring, anti-rattle. Late 1950-60 Commander 6-cylinder. **\$5.25 ea.**
530009 Thermostatic spring. All 1951-64 V-8. **\$15.00 ea.**
533118 1951-54 V-8. NOS. **\$150.00 ea.**
536171 Replacement valve. 1955-64 V-8 (complete) & 1963-64 Avanti. **\$80.00 ea.**
1551446 Valve. 1961-64 6-cylinder. **\$12.00 ea.**
1551986 Thermostat. 1961-64 6-cylinder. **\$12.00 ea.**
1554197 Bushing. 1961-64 OHV 6-cylinder. **\$8.25 ea.**
1554198 Shaft. 1962-64 6-cyl **\$19.00 ea.**
NEW Listing - 1564075 Shaft. 1965-66 6-cylinder. **\$3.00 ea.**

Heat Riser Complete Valve Kits

1939-60 CHAMPION 6-cylinder

Kit includes:

- 196414 gasket
- 196655 valve & shaft
- 196661 thermostat
- 196662 balance weight. plus set screw
- 515821 bushing (2)
- 520458 plug

Total of all parts if purchased separately. **\$75.50**

801354
Special Package Price \$68.00 ea.

1961-64 O.H.V. 6-cylinder

Kit includes:

- 179369 screw
- 196662 balance weight
- 515821 bushing (1) plus set screw
- 1551446 valve
- 1551986 thermostat
- 1554197 bushing
- 1554198 shaft

Total of all parts if purchased separately. **\$87.50**

801355
Special Package Price \$79.00 ea.

Late **1950-60**

COMMANDER 6-cylinder

Kit includes:

- 179369 screw
- 199006 screw
- 515821 bushing (2)
- 515835 balance wt.
- 525315 shaft
- 525316 thermostat
- 525317 pin
- 525319 spring

Total of all parts if purchased separately. **\$103.75**

801356
Special Package Price \$94.00 ea.

MANIFOLD INTAKE & EXHAUST

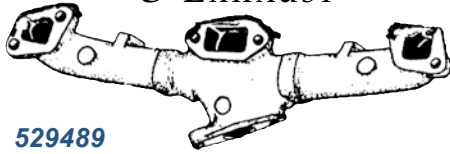

- 529489** Right exhaust manifold. 1951-54 V-8 **\$130.00 ea.**
529490 Left exhaust manifold. 1951-52 V-8. **\$120.00 ea.**
536194 Right exhaust manifold. All 1955-62 V-8. **\$80.00 ea.**
536195 Left exhaust manifold. All 1955-64 V-8. **\$145.00 ea.**
1551330 Intake, 1960-64. 2-bbl V-8. **\$85.00 ea.**
1551449 Exhaust, 1961-64 OHV 6-cylinder Includes heat riser. **\$150.00 ea.**
1558255 Right exhaust manifold. 1963-64 Avanti. **\$150.00 ea.**
1559666 Right exhaust, 1963-64 except Avanti. V-8. **\$90.00 ea.**
NEW Listing - 1564084 Inlet & exhaust manifold to head. 1965-66 6-cylinder. **\$3.00 ea.**

INTAKE & EXHAUST MANIFOLD GASKETS



- 177976** Intake & exhaust, 8-cylinder. 1938-42 Commander & President. **\$22.00 pr.**
196693 Intake & exhaust, 6-cylinder. 1939-60 Champion. NOS. **\$15.00 ea.**
510066 Intake & exhaust, 6-cylinder. 1935-60 Commander. **\$16.75 ea.**
530266 Metal intake. 1951-64 V-8 & 1963-64 Avanti. **\$13.50 pr.**
801233 Composition intake. 1951-64 V-8 & 1963-64 Avanti. **\$13.50 pr.**
800397 Metal exhaust. 1955-64 V-8 & 1963-64 Avanti. **\$28.00/set 9**
800397X1 Exhaust manifold. 1951-64 V-8. **\$17.50/SET 9**
801246 Composition exhaust. 1955-64 V-8 & 1963-64 Avanti. **\$15.00/set 9**
1551403 Inlet to exhaust manifold. 1961-64 6-cylinder. **\$6.00 ea.**
1551869 Manifold to block. 1961-64 6-cylinder. **\$15.00 ea.**
1555713 Composition intake. 1963-64 Avanti R-3; R-4. **\$16.00 pr.**
1564080 Inlet to exhaust. 1965-66 6-cylinder. **\$1.50 ea.**

CAST IRON HEADERS



- 801092** Standard on 1963-64 Avanti R-3 & R-4, optional on R-1 & R-2. Improves performance and increases fuel economy on all V-8 equipped Studebaker. **\$385.00 pr.**
801093 Header to exhaust pipe. Used with 801092. Stainless. **\$135.00 pr.**
801209 Alternator/generator bracket for mounting 801092 headers in Lark or Hawk. Not needed for Avanti. **\$85.50/kit**



PRE-WAR MANIFOLD GASKETS

- 43494** Exhaust pipe flange gasket. 1928-32 all 6-cylinder. **\$10.00 ea.**
156526 Exhaust pipe flange gasket. 1929-32 President 8. **\$10.00 ea.**
168653 Divider gasket, inlet to exhaust manifold. 1931-32 Dictator 8 & 1930-32 Commander 8. **\$10.00 ea.**
172436 Divider gasket, inlet to exhaust manifold. 1932 Rockne 85 and 1931-32 Studebaker 54-55. **\$10.00 ea.**
178230 Divider gasket, inlet to exhaust manifold. 1933 Commander & President 8. **\$10.00 ea.**
178270 Divider gasket, inlet to exhaust manifold. 1933 Studebaker 56. **\$10.00 ea.**
184778 Divider gasket, inlet to exhaust manifold. 1934 Dictator. **\$10.00 ea.**
185075 Divider gasket, inlet to exhaust manifold. 1935 Dictator. **\$10.00 ea.**
187003 Divider gasket, inlet to exhaust manifold. 1936-42 Dictator & Commander 6-cylinder. **\$10.00 ea.**
510066 Block to manifold. 1934-42 Dictator & Commander 6-cylinder. **\$16.75 ea.**
633100 Exhaust pipe flange gasket. 1933 Studebaker 6-cylinder & 1933-42 8-cylinder. **\$10.00 ea.**
680291 Exhaust pipe flange gasket. 1939-46 Champion. **\$2.50 ea.**
680292 Exhaust pipe flange gasket. 1936-42 Commander 6-cylinder **\$2.50 ea.**



MANIFOLD INTAKE CLAMP

- 535617P** 1951-64 V-8 car & truck & 1963-64 Avanti. Takes 4. **NLA**

WATER PUMP MANIFOLD SEALS



- 527240** Water pump manifold seal. Upper, 1951-64 V-8 & 1963-64 Avanti. Takes 2. Temperature sender plate. Takes 2. **\$1.00 ea.**
527856 Water pump manifold seal. Lower, 1951-64 V-8 & 1963-64 Avanti. Takes 2. **\$1.00 ea.**



CHOKE TUBE

- 1557361** Pipe, choke to manifold. 1963-64 V-8 with 4-BBL & 1963-64 Avanti. **\$18.50 ea.**

U-BOLT & SADDLE ASSEMBLY

- 1547588** Clamp. Header pipe to exhaust pipe. 1959-64 V-8 including Avanti. Takes 2. **\$30.00 ea.**



EXHAUST DEFLECTORS

AC-2701

- Original accessory for most models 1947-55 and 1956 Hawk. Quality reproduction, beautiful finish. **\$99.95 ea.**



AC-2754

- Originally available on 1956-57 Hawks and Station Wagons.

- Chrome finish. Dresses up tailpipe and prevents exhaust gases from marring car finish. **\$85.00 ea.**

AC-2771

- Chrome exhaust tip. 1956 sedan, not Hawk. NOS. **\$35.50 ea.**



AC-2840

- Original factory accessory 1957-64 Hawk & 1957-58 sedan. Excellent quality

- stainless steel reproduction. **\$92.50 ea.**



- AC-3339** 1963-85 Avanti. Chrome. **\$60.00 ea.**

FLANGE REPAIR KITS

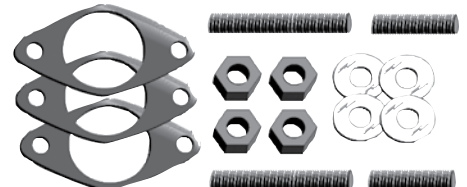

- 800236** 1939-60 Champion 6-cyl. Contains 2 new studs, washers, brass nuts and a composition gasket. **\$12.50 ea.**

- 800266** 1955-64 V-8 all models & 1963-64 Avanti. Contains 4 new studs, washers, brass nuts & 3 composition gaskets. **\$16.50 ea.**

- 800266X1** 1951-54 V-8 all models. Contains 4 new studs, washers, brass nuts & 3 gaskets. **\$16.50 ea.**

- 800791** 1938-50 Commander 6-cylinder & all Commander 6-cylinder truck through 1960 with 2 bolt flange. Contains 2 new studs, washers, brass nuts & a composition gasket. **\$12.50 ea.**

MANIFOLD GUARD

NEW Listing 1564233

- Guard, intake manifold oil splash. 1965-66 V-8. **\$10.00 ea.**



Mufflers

New old stock or Remanufactured old stock

Availability on these items ranges from just a few to a dozen or more.



- 127404** 1928 - 29 Dictator 6 and 1929 Commander 6. Models with GE and GJ. **\$250.00 ea.**
- 167984** 1929 - 30 model GL Dictator 6, prior to serial number 1, 475,137..... **\$250.00 ea.**
- 173125** 1930 Dictator 6 after serial number 1,475,137. **\$250.00 ea.**
- 173649** 1932 Studebaker 6, model 55. **\$250.00 ea.**
- 180879** 1934 President. **\$250.00 ea.**
- 184256** 1935 Dictator. **\$250.00 ea.**
- 184618 & 512212** 1935 Commander 8 and early 1936 President, front. **\$250.00 ea.**
- 184619** Front for late 1936 President. **\$250.00 ea.**
- 184620** 1935 Commander 8 and 1935-36 President, rear. **\$250.00 ea.**
- 187510** 1936 Dictator. **\$250.00 ea.**
- 197413** 1939-41 Champion. . **\$150.00 ea.**
- 198408** 1937-48 President. . **\$250.00 ea.**
- 198503** 1937-42 Dictator and Commander. Also 1937-39 Coupe Express. .. **\$250.00 ea.**
- 199485** 1941-42 President. .. **\$250.00 ea.**
- 515656** 1942-46 Champion. . **\$125.00 ea.**

- 521214** 1935 Dictator. **\$250.00 ea.**
- 536409** 1955 V-8 with single exhaust. **\$125.00 ea.**
- 661556** 1941-64 truck with Commander 6-cylinder engine. **\$150.00 ea.**
- 663647** ½ ton & ¾ ton 1941-64 truck with Champion 6-cylinder engine. **\$150.00 ea.**
- 682148** 1954-56 truck, 3R-2E 13, 28, & 38. **\$150.00 ea.**
- 684435** 1955-64 truck, E-8E 2, 7, & 12. **\$150.00 ea.**
- 1548424** 1959-66 Lark, 2-door and station wagon with sliding roof. **\$125.00 ea.**
- 1549213** 1955 with single exhaust. Aluminized. **\$125.00 ea.**
- 1554308** 1962-66 6-cylinder Lark, 4-door all except station wagon with sliding roof. **\$125.00 ea.**
- 1555447** 1962-66 6-cylinder Lark, 4-door all except station wagon with sliding roof. Aluminized. **\$125.00 ea.**
- 1687675** 1957-64 truck. 3E-8E 13, 28, 38, & 40. **\$150.00 ea.**

EXHAUST STRAPS & SUPPORTS

- 189393** Tail pipe support rubber strap. 1937-42 Commander & President. 1939-46 Champion. Muffler support. 1941-64 truck. **\$6.50 ea.**
- 517913** Hanger, outlet pipe 1947-49 Champion. **\$4.00 ea.**
- 517914** Tail pipe hanger rubber strap. 1947-50 all models. 1953 all models. **\$4.20 ea.**
- 518002** Hanger, outlet pipe 1947-49 Commander. **\$7.50 ea.**
- 526460** Tail pipe hanger rubber strap. 1949-50 Commander, 1950 Champion, 1951-66 most models. **\$2.50 ea.**
- 532466** Hanger, outlet. 1953 Commander sedan..... **\$7.50 ea.**

- 532471** Hanger, outlet. 1953 Champion sedan..... **\$7.50 ea.**



Includes 1553904 strap. **\$22.00 ea.**

- 800543** Rear support strap & brackets. 1960-64 convertible. 1963-66 Wagonaire. 1963-85 Avanti. **\$3.50 ea.**

- 1544725** Rear strap with bracket. Most models & 1963-85 Avanti. Pictured, left **\$3.50 ea.**

- 1544725X1** Rear strap only. Most models & 1963-85 Avanti. **\$2.00 ea.**

- 1553904** Rear support strap. 1960-64 convertible. 1963-66 Wagonaire & 1963-85 Avanti. **\$3.95 ea.**

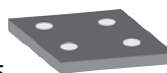

EXHAUST FLANGE SEAL GASKETS

- 680291** 1939-64 Champion 6-cyl. **\$2.50 ea.**
- 680292** Exhaust pipe flange gasket. 1936-50 car with Commander 6, Truck: 1934-60 with Commander 6. (2 hole). **\$2.50 ea.**
- 680847** Truck: 2R & E-5E, 3, 6, 11, 14, 16, 17. (3 hole). **\$2.00 ea.**
- 800398** 1955-64 V-8. Thick composition type. All models & 1963-64 Avanti.. **\$2.75 ea.**
- 530263** 1951-54 V-8. Metal. **\$2.00 ea.**

Head Rebuild Kits

for 1955-64 259 & 289 V-8

Kit includes:

- 1 valve grind gasket kit
- 8 exhaust valves
- 8 intake valves
- 8 exhaust valve seats
- 8 intake valve seats
- 8 exhaust valve guides
- 8 intake valve guides
- 16 valve springs
- 4 rocker arm end plugs & cotter pins
- 1 can aerosol engine enamel
- 1 silicone gasket sealer (tube)

1955-64 259 or 289 V-8 except Avanti

Total of all parts listed if purchased separately. \$717.50

Special kit Price..... \$650.00

— 10% quantity discount. See page 4. \$65.00

801028R Your cost \$585.00 ea.

1957-58 289 V-8 with supercharger

Total of all parts listed if purchased separately. \$743.00

Special kit price..... \$670.00

— 10% quantity discount. See page 4. \$67.00

801029R Your cost \$603.00 ea.

1963-64 AVANTI jet thrust R-1

Total of all parts listed if purchased separately. \$714.25

Special kit price..... \$645.00

—10% quantity discount. See page 4. \$64.50

801168R Your cost..... \$580.50 ea.

1963-64 AVANTI

jet thrust R-2 supercharged

Total of all parts listed if purchased separately. \$739.75

Special kit Price..... \$668.00

— 10% quantity discount. See page 4. \$66.80

801169R Your cost..... \$601.20 ea.

NOTE: WHEN ORDERING SPECIFY YEAR AND MODEL OF CAR. NO SUBSTITUTIONS OR DELETIONS.

PRE-WAR MANIFOLD HEATER VALVE COVER GASKETS

- 170052** 1930 Studebaker 6-cylinder. **\$8.00 ea.**
- 177731** All 1933 8-cylinder. **\$8.00 ea.**
- 180054** 1934-42 8-cylinder. **\$8.00 ea.**

- 183640** 1935 Dictator 6-cylinder. **\$8.00 ea.**
- 510068** 1932-33 Rockne 65 & 75 and 1934 Dictator 6-cylinder. **\$8.00 ea.**

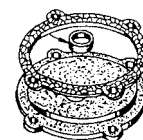

Contains all Gaskets & Seals for a Complete Engine Overhaul.

1936-37 DICTATOR

Without rear main seal

801270

Special kit price..... \$140.00/set

Kit Includes:

- 2 Ea. G113897 Oil pressure relief & oil pan plug
- 1 Ea. 167156 ... Crankshaft washer, front
- 1 Ea. 172622 Oil pump cover
- 1 Ea. 186668 Timing gear cover
- 1 Ea. 186710 Oil pan
- 1 Ea. 187003 Manifold divider
- 2 Ea. 187106Rear main bearing cap (Wood)
- 1 Ea. 197389 Fuel pump
- 1 Ea. 189163 Water pump
- 1 Ea. 189326 Water pump
- 1 Ea. 192105 Carburetor base
- 1 Ea. 510131 Distributor
- 1 Ea. 510193 Oil pump body
- 1 Ea. 523145 Front plate

Valve Grind Gasket Set 800390

(Includes the following)

- 1 Ea. 186888 Thermostat
- 1 Ea. 510066Intake and exhaust manifold
- 1 Ea. 527057 Cylinder head
- 1 Pr. 196126 Valve lifter cover
- & 4 ea. 156768 with screw gaskets

1939-47 CHAMPION

Without rear main seal

801269

Special kit price..... \$120.00/set

Kit Includes:

- 1 Set S-346 Oil pan
- 1 Ea. G113897 Oil pan plug washer
- 1 Ea. 192125 ... Oil pressure relief washer
- 1 Ea. 194219 Front cover
- 1 Ea. 194484 Front plate
- 1 Ea. 195304 Oil pump (Body)
- 1 Ea. 196414 Heat riser valve cover
- 2 Ea. 197178 Rear main cap (Wood)
- 1 Ea. 197591 Front crankshaft
- 1 Ea. 510131 (1561173)Distributor
- 1 Ea. 521371 Oil pump (Cover)
- 1 Ea. 522070 Carburetor base
- 2 Ea. 522144 Rear main cap
- 1 Ea. 534123 Oil pump suction
- 1 Ea. 534597 Water pump
- 1 Ea. 680291 Pipe flange

1 Set 800389

Valve Grind Gasket Set

(Includes the following)

- 1 Ea. 194194 PCV valve adapter (Breather Tube)
- 1 Ea. 194658 ... Thermostat (Upper)
- 1 Ea. 194660 ... Thermostat (Lower)
- 1 Ea. 196693 ... Intake and exhaust manifold
- 1 Ea. 534598 Cylinder head
- 1 Pr. 536554 ... Valve lifter cover
- & 4 ea. 156768... with screw gaskets

1948 COMMANDER, M16 17 & EARLY 2R 16 & 17

TRUCKS WITH

226 CUBIC INCH 6-CYL.

Includes rear main seal.

801271

Special kit price..... \$225.00/set

Kit Includes:

- 2 Ea. G113897Oil pressure relief and oil pan plug
- 1 Ea. 167156 ... Crankshaft washer, front
- 1 Ea. 172622 Oil pump cover
- 1 Ea. 186668 Timing gear cover
- 1 Ea. 186710 Oil pan
- 1 Ea. 187003 Manifold divider
- 2 Ea. 187106Rear main bearing cap (Wood)
- 1 Ea. 192105 (522070) ... Carburetor base
- 1 Ea. 197389 Fuel pump
- 1 Ea. 510131 Distributor
- 1 Ea. 510193 Oil pump body
- 1 Ea. 519371 Water pump
- 1 Ea. 519434 Water pump
- 2 Ea. 522144Rear main bearing cap (Rubber)
- 1 Ea. 523145 Front plate
- 1 Ea. 525945 Rear main
- 1 Ea. 680292 Exhaust pipe flange

1 Set 800390

Valve Grind Gasket Set

(Includes the following)

- 1 Ea. 186888 Thermostat
- 1 Ea. 510066Intake and exhaust manifold
- 1 Ea. 527057 Cylinder head
- 1 Pr. 196126 ... Valve lifter cover
- & 4 ea. 156768... with screw gaskets

1949-60 COMMANDER 6

With rear main seal

801272

Special kit price..... \$168.00/set

Kit Includes:

- 2 Ea. G113897Oil pressure relief and oil pan plug
- 1 Ea. 167156 ... Crankshaft washer, front
- 1 Ea. 526203 Oil pump cover
- 1 Ea. 186668 Timing gear cover
- 1 Ea. 186710 Oil pan
- 1 Ea. 187003 Manifold divider
- 1 Ea. 191662 (523145)Front plate
- 1 Ea. 197389 Fuel pump
- 1 Ea. 510131 Distributor
- 1 Ea. 510193 Oil pump body
- 1 Ea. 519371 Water pump
- 1 Ea. 519434 Water pump
- 1 Ea. 522070 Carburetor base
- 1 Ea. 680292 Exhaust pipe flange
- OR (2 stud mounting holes)
- 1 Ea. 680847 Exhaust pipe flange (Trucks with 3 stud mounting holes)

1 Ea. 1540603..... Rear main

1 Set 800390

Valve Grind Gasket Set

(Includes the following)

- 1 Ea. 186888 Thermostat
- 1 Ea. 510066Intake and exhaust manifold
- 1 Ea. 527057 Cylinder head
- 1 Pr. 196126 ... Valve lifter cover
- & 4 ea. 156768... with screw gaskets

1938-47 6-CYL. COMMANDER

Without rear main seal

800385

Special kit price..... \$108.00/set

Kit Includes:

- 2 Ea. G113897Oil pressure relief and oil pan plug
- 1 Ea. 167156 ... Crankshaft washer, front
- 1 Ea. 172622 Oil pump cover
- 1 Ea. 186668 Timing gear cover
- 1 Ea. 186710 Oil pan
- 1 Ea. 187003 Manifold divider
- 2 Ea. 187106Rear main bearing cap (Wood)
- 1 Ea. 191662 (523145)Front plate
- 1 Ea. 197389 Fuel pump
- 1 Ea. 510131 Distributor
- 1 Ea. 510193 Oil pump body
- 1 Ea. 519371 Water pump
- 1 Ea. 519434 Water pump
- 1 Ea. 522070 Carburetor base
- 2 Ea. 522144Rear main bearing cap (Rubber)
- 1 Ea. 680292 Exhaust pipe flange (2 stud mounting holes)

1 Set 800390

Valve Grind Gasket Set

(Includes the following)

- 1 Ea. 186888 Thermostat
- 1 Pr. 196126 Valve lifter cover
- & 4 ea. 156768 ... with screw gaskets

- 1 Ea. 510066 Cylinder head
- 1 Ea. 527057 ... Intake and exhaust manifold

1948-54 6-CYL.

CHAMPION With rear main seal

800383

Special kit price..... \$179.00/set

Kit Includes:

- 1 Ea. 1540604..... Rear main
- 1 Set S-346 Oil pan
- 1 Ea. G113897 Oil pan plug washer
- 1 Ea. 192125 ... Oil pressure relief washer
- 1 Ea. 194219 Front cover
- 1 Ea. 194484 Front plate
- 1 Ea. 195304 Oil pump (Body)
- 1 Ea. 196414 Heat riser valve cover
- 1 Ea. 197591 Front crankshaft
- 1 Ea. 510131 (1561173)Distributor
- 1 Ea. 521371 Oil pump (Cover)
- 1 Ea. 522070 Carburetor base
- 1 Ea. 534123 Oil pump suction
- 1 Ea. 534597 Water pump
- 1 Ea. 680291 Pipe flange
- 1 Set 800389

Valve Grind Gasket Set

(Includes the following)

- 1 Ea. 194194 Breather Tube
- 1 Ea. 194658 ... Thermostat (Upper)
- 1 Ea. 194660 ... Thermostat (Lower)
- 1 Ea. 196693Intake and exhaust manifold
- 1 Ea. 534598 Cylinder head
- 1 Pr. 536554 ... Valve lifter cover
- & 4 ea. 156768... with screw gaskets

1955-EARLY 1960 V-8

With rear main seal

800386*

Special kit price..... \$215.00/set

Kit Includes:

- 1 Ea. G113897 Oil pan plug (1955 - 1958)
- OR 1 Ea. 1552264 Oil pan plug (1959)
- 3 Ea. 156768 Valve lifter cover screw
- 1 Ea. 167156 ... Crankshaft washer, front
- 1 Ea. 192125 Oil pressure relief
- 1 Ea. 440613. Carburetor base (4BBL)
- 1 Ea. 527224 Oil pump
- 1 Ea. 533010 Distributor
- 1 Ea. 535697 Filler tube
- 1 Ea. 537354 Fuel pump
- 1 Set 802256

Valve Grind Gasket Set

(Includes the following)

- 1 Ea. 510550 Breather tube
- 3 Ea. 527240 Water pump manifold, upper
- 1 Ea. 527246 water pump
- 1 Ea. 527284 Thermostat
- 2 Ea. 527856 Water pump manifold, lower
- 1 Pr. 530266 Intake manifold
- 16 Ea. 536264 Valve stem
- 1 Pr. 536555X Rocker cover
- - Includes (8) 530858 grommets
- 1 Set 801246 Exhaust manifold
- 2 ea. 1545072 (Included) Cylinder head
- OR 535982 Add \$35.00 for thicker Cylinder head gaskets

- 1 Ea. 1540006 ... Carburetor base (2BBL)
- 1 Ea. 1559366 Rear main
- 1 Ea. 1561166 Front cover
- 1 Set 1561169 Valve lifter cover
- 1 Ea. 1561465 Oil pan

1951-54 V-8. COMMANDER

With rear main seal

800387

Special kit price..... \$155.00/set

Kit Includes:

- 1 Ea. G113897 Oil pan plug washer
- 1 Ea. 167156 ... Crankshaft washer, front
- 1 Ea. 177979 (use 684059) Carburetor base
- 1 Ea. 192125 Oil pressure relief
- 1 Ea. 197389 Fuel pump
- 1 Ea. 527214 Distributor
- 1 Ea. 527224 Oil pump
- 1 Ea. 527246 Water pump
- 1 Ea. 531640 Fuel pump support
- 1 Set 800975

Valve Grind Gasket Set

(Includes the following)

- 1 Ea. 510550 Breather tube
- 3 Ea. 527240 Water pump manifold, upper
- 1 Ea. 527284 Thermostat
- 2 Ea. 527856 Water pump manifold, lower
- 1 Pr. 530266 Intake manifold
- 16 Ea. 527191 Valve stem
- 1 Set 800397X1 ... Exhaust manifold
- 2 Ea. 529321 Cylinder head
- 1 Pr. 536555X Rocker cover
- & 8 ea. 530858 with valve cover grommets

- 1 Ea. 1559366 Rear main seal
- 1 Ea. 1561166 Timing cover
- 1 Set 1561169 Valve lifter cover
- With screw gaskets (3)
- 1 Ea. 1561465 Oil pan

1955-60 6-CYL. CHAMPION

With rear main seal

800384

Special kit price..... \$144.00/set

Kit Includes:

- 1 Ea. G113897 Oil pan plug washer
- (1955-58)
- OR 1552204 Oil pan plug washer
- (1959-60)
- 1 Ea. 192125 Oil pressure relief
- 1 Ea. 195304 Oil pump body
- 1 Ea. 196414 Heat riser valve cover
- 1 Ea. 197591 Front crankshaft
- 1 Ea. 521371 Oil pump body cover
- 1 Ea. 532733 Carburetor base (1955 - 1958)
- OR 2 Ea. 1549319 Carburetor base
- (1959 - 1960)

Valve Grind Gasket Set

(Includes the following)

- 1 Ea. 196693 Manifold
- 1 Ea. 510131 (1561173) Distributor
- 1 Ea. 534123 Oil pump suction
- 1 Ea. 534597 Water pump
- 1 Ea. 680291 Pipe flange
- 1 Set 1554698 Rear main
- 1 Set 1561429 Oil pan
- 1 Set 800389

Valve Grind Gasket Set

(Includes the following)

- 1 Ea. 194194 Breather Tube
- 12 Ea. 194658 .. Thermostat (Upper)
- 1 Ea. 194660 .. Thermostat (Lower)
- 1 Ea. 534598 Cylinder head
- 1 Pr. 536554 Valve lifter cover
- & 4 ea. 156768... with screw gaskets
- 1 Ea. 1561168 Front plate
- 1 Ea. 1561172 Front cover

*LATE 1960 V-8 With rear main seal

801273*

Special kit price..... \$215.00/set

Kit Includes:

- 1 Ea. 167156 ... Crankshaft washer, front
- 1 Ea. 192125 Oil pressure relief
- 1 Ea. 440613. Carburetor base (4BBL)
- 1 Ea. 527224 Oil pump
- 1 Ea. 533010 Distributor
- 1 Ea. 535697 Oil Filler tube
- 1 Ea. 537354 Fuel pump
- 1 Set 802255

Valve Grind Gasket Set

(Includes the following)

- 1 Ea. 510550 Breather tube
- 3 Ea. 527240 Water pump manifold, upper
- 1 Ea. 527246 water pump
- 1 Ea. 527284 Thermostat
- 2 Ea. 527856 Water pump manifold, lower
- 1 Pr. 530266 Intake manifold
- 16 Ea. 536264 Valve stem
- 1 Pr. 1561165X Rocker cover
- - Includes (8) 530858 grommets
- 1 Set 801246 Exhaust manifold
- 2 ea. 1545072 (Included) Cylinder head
- OR 535982 Add \$35.00 for thicker Cylinder head gaskets

- 1 Ea. 1540006 ... Carburetor base (2BBL)
- 1 Ea. 1552264 Oil pan plug
- 1 Ea. 1559366 Rear main
- 1 Ea. 1561166 Front cover
- 1 Set 1561169... Valve Lifter Cover (Valley Cover)
- 1 Set 1561465 Oil pan set
- 3 Ea. 156768 Valve lifter cover screw

1961-EARLY 62 V-8 W/rear main seal

Same as above except replace Valve grind set 802255 with 800391

801274 Special kit price \$215.00/set

1961-64 6-CYL. With rear main seal

800382

Special kit price..... \$144.00/set

Kit Includes:

- 1 Ea. 192125 Oil pressure relief
- 1 Ea. 197591 Crankshaft front
- 2 Ea. 530858 Grommet
- 1 Ea. 534123 Oil pump suction
- 1 Ea. 534597 Water pump
- 1 Ea. 537354 Fuel pump
- 1 Ea. 680291 Pipe flange
- 1 Set 800388

Valve Grind Gasket Set

(Includes the following)

- 1 Ea. 194194 PCV valve adapter (1961-63)
- (Breather Tube)
- 12 Ea. 536264 Valve stem
- 1 Ea. 1550816 Thermostat
- 1 Ea. 1551869 ... Intake and Exhaust
- Manifold
- 1 Ea. 1693440 Cylinder head
- 1 Ea. 1561167 Rocker cover
- 1 Pr. 536554 Valve lifter cover
- & 4 ea. 156768 with screw gaskets

- 1 Ea. 1551403 Manifold divider
- 1 Ea. 1543376 Oil pump
- 2 Ea. 1549319 Carburetor base
- 1 Ea. 1552264 Oil pan plug
- 1 Ea. 1554698 Rear main
- 1 Ea. 1555103 Oil filter base (for 1963-64 only)
- 1 Ea. 1561168 Front plate
- 1 Ea. 1561172 Front cover
- 1 Ea. 1561173 Distributor
- 1 Set 1561429 Oil pan

*1962-64 (FULL FLOW) V-8

With rear main seal

801275*

Special kit price..... \$215.00/set

Kit Includes:

- 1 Ea. 167156 ... Crankshaft washer, front
- 1 Ea. 192125 Oil pressure relief
- 1 Ea. 440613. Carburetor base
- (4BBL) 1962 (WCFB) OR
- 1 Ea. 1557002 1963-64 - (AFB)
- 1 Ea. 527224 Oil pump
- 1 Ea. 533010 Distributor
- 1 Ea. 535697 .. Oil Filler tube (block off plate)
- 1 Ea. 537354 Fuel pump
- 1 Set 800391

Valve Grind Gasket Set

(Includes the following)

- 1 Ea. 510550 Breather tube
- 3 Ea. 527240 Water pump manifold, upper
- 1 Ea. 527246 water pump
- 1 Ea. 1550816 Thermostat
- 2 Ea. 527856 Water pump manifold, lower
- 1 Pr. 530266 Intake manifold
- 16 Ea. 536264 Valve stem
- 1 Pr. 1561165X Rocker cover
- - Includes (4) 530858 grommets
- 1 Set 801246 Exhaust manifold
- 2 ea. 1545072 (Included) ... Cylinder head
- OR 535982 Add \$35.00 for thicker Cylinder head gaskets

- 1 Ea. 1540006 ... Carburetor base (2BBL)
- 1 Ea. 1552264 Oil pan plug
- 1 Ea. 1555103 Oil filter base
- 1 Ea. 1559366 Rear main
- 1 Ea. 1561166 Front cover
- 1 Ea. 1561169... Valve Lifter Cover (Valley Cover)
- 1 Set 1561465 Oil pan set
- 3 Ea. 156768 Valve lifter cover screw

ENGINES & ENGINE BLOCKS

- 535435** Engine Assembly, stripped service. 6-cylinder 185 cubic inch engine. Call
- 1548985** Cylinder block with fitted pistons. 1959-60 170 cubic inch engine. . **\$700.00 ea.**
- 1564873** Cylinder block. 1965-66 283 V-8 engine. Includes pistons. **\$700.00 ea.**
- 1564868** Cylinder block. 1965-66 6-cylinder cars with .194 cubic inch engine. Includes pistons. **\$500.00 ea.**
- 1565702** Cylinder block. 1966 6-cylinder cars with .230 cubic inch engine. **\$650.00 ea.**



ENGINE FILLER BLOCK

- 527123** Front filler block. 1951-64 V-8 & 1963-64 Avanti. **\$53.00 ea.**
- NEW Listing - 535996** 1955-64 6-cylinder Champion. **\$35.00 ea.**

HIGH TEMPERATURE ENGINE ENAMEL

NOTE: THIS HIGH QUALITY ENAMEL IS MIXED TO MATCH THE ORIGINAL COLORS USED BY THE FACTORY WHEN YOUR CAR WAS NEW. COMES IN 12 OZ. AEROSOL CAN, READY TO SPRAY.



- 800254** Green. 1954 & earlier. **\$13.75 can**
- 800255** Blue. 1955. **\$13.75 can**
- 800256** Turquoise 1956-57. **\$13.75 can**
- 800257** Silver. 1958-61. **\$13.75 can**
- 800258** Yellow. 1962-65 valve covers. 1962-66 trans dip stick. **\$13.75 can**
- 800259** Orange. 1962-65 fan, oil cap & supercharger. **\$13.75 can**
- 800689** Black. 1962-66 car & truck & 1963-64 Avanti. **\$10.50 can**
- 801922** Reduced sheen black enamel for radiators and other engine parts without a high gloss finish. **\$13.75 can**
- 801926** Reddish orange. 1961 valve covers. **\$13.75 can**

Note: We're sorry but due to air freight restrictions we cannot ship paint anywhere overseas or by airmail.

ENGINE ENAMEL QUART



- 800810** Green. 1954 & Earlier. **\$56.95 qt**
- 800811** Blue. 1955. **\$56.95 qt**
- 800812** Turquoise. 1956-57. **\$56.95 qt**

ENGINE TO FRAME BRACKETS

- 529342** Right or left front, on block. 1951-52 Commander. **\$12.00 ea.**
- 530213** Left front, on frame. 1951-52 Champion. **\$20.00 ea.**
- 532404** Bracket, front engine mount to block. 1953-64 V-8, all models including Avanti. **\$15.00 ea.**



- 1547208** Left front, on frame. 1959-64 6-cylinder, Lark. **\$20.00 ea.**



- 1550462** Right front, on frame. 1961-64 6-cylinder. **\$20.00 ea.**

- 1551242** Right front, on block. 1961-62 6-cylinder. **\$15.50 ea.**



- 532398** Right front, on frame. 1953-58 Champion sedan. **\$20.00 ea.**
- 532399** Left front, on frame. 1953-58 Champion sedan. **\$20.00 ea.**
- 532400** Right front, on frame. 1953-58 V-8 sedan. Pictured, above left. **\$20.00 ea.**
- 532401** Left front, on frame. 1951-58 V-8. Pictured, above right. **\$20.00 ea.**
- 536202** Right front, on frame. 1955-60 6-cylinder sedan. **\$20.00 ea.**



- NEW Listing - 1563588** bracket, right front engine support. 1965 - 66 6-cylinder car with standard transmission. **\$5.00 ea.**
- NEW Listing - 1563589** bracket, left front engine support. 1965 - 66 6-cylinder car with standard transmission. **\$5.00 ea.**

- 532402** Right front, on block. 1953-54 Champion. **\$15.00 ea.**
- 532403** Left front, on block. 1953-54 Champion. **\$15.00 ea.**
- 536223** Left front, on frame. 1953-60 6-cylinder C & K. **\$18.00 ea.**



- 683979** Bracket, rear trans support with auto trans. Truck: 2E 7 before serial number E7 - 6,562 & 2E 12 before serial number 2E 12-2,629. **\$99.95 ea.**

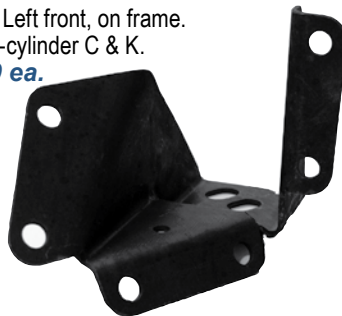

- 1563714-5** Engine to frame brackets for 1965-66 models. Can be used on earlier model sedans except C & K & Avanti to convert to Chevrolet engine. **\$185.00 pr.**

- NEW Listing - 1563745** bracket, rear engine support. 1965 - 66 6-cylinder car with standard transmission. **\$6.00 ea.**
- NEW Listing - 1563804** bracket, rear engine support. 1965 - 66 6-cylinder car with overdrive. **\$20.00 ea.**

- 1686126** Rear trans. Support for automatic transmission. 2E7 & 2E12 after 683979 & 3E & 4E 2, 7, 12, 13. **\$99.95 ea.**

- 1692223** Bracket, rear automatic transmission support. Truck: 5E-8E. Champ only. **\$99.95 ea.**

- NEW Listing - 801830** Front bracket, Chevy V-8 to C & K. 1953-64. **\$155.00 ea.**



Major Rebuild Kits for 1939-63

Champion 6-Cyl.

- Complete gasket kit
- Cam bearings. Standard
- Camshaft timing gear
- 1939-54 Aluminum or 1955-64 fiber
- Main bearings — choice of:
1939-54 std., .001, .010, .020
(.030 .060 at extra cost)
1955-62 CRN/Partial Flow std.,
.001, .002, .010 (.020 or .030 at extra cost)
1963-64 Full Flow std., .010
(.020 or .030 at extra cost)
- Rod bearings — choice of:
1939-64 std., .002, .005, .010, .020,
.030, .040 .060
not included in 801021X1
- Rods (w/Babbit Bearings)
1939-40 Champion head w/casting
#194777

- Rods to convert Babbit bearing engines to insert-type. 1939-46 Champion head w/casting #199697
- Oil pump kit only (1939-60) with 1½" gears
- Oil pump kit, complete (1961-63) with 1½" gears
- Oil pressure relief valve
- Oil pressure relief valve spring & washer
- Pistons — choice of: std., +.020, +.030, +.040 or +.060
- Piston rings — choice of: std., +.020, +.030, +.040 or +.060
- Crankshaft timing gear
- Crankshaft damper cushions (1942-64 only)
- 6 exhaust valves
- 6 intake valves

- 12 valve guides
- 6 exhaust valve seats
- 6 intake valve seats
- 12 valve springs
- 6 freeze plugs
- 1 camshaft plug
- 2 rocker arm end plugs (1961-63 only) not included in 801021X1, X2 or X3
- 12 valve lifters (1961-63 only) not included in 801021X1, X2 or X3
- 2 cans aerosol engine enamel
- 2 silicone gasket sealer (tube)
- 1 lock plate
- 801354 heat riser kit. 1939-60
- 801355 heat riser kit. 1961-64

Kit includes:

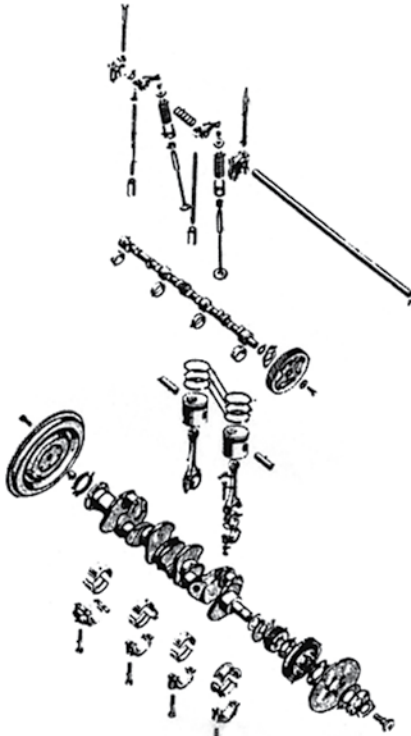

1939-46 CHAMPION 6-cylinder with cylinder head having casting #199697 Excludes oil pump kit.

Total of all parts listed if purchased separately\$1941.25
Special kit price..... \$1845.00
—15% quantity discount. See page 4. \$276.75
801021X2R Your cost \$1568.25 ea.

1948 -54 CHAMPION 6-cylinder
Total of all parts listed if purchased separately\$2171.00
Special kit price \$2064.00
—15% quantity discount. See page 4. \$309.60
801021R Your cost..... \$1754.40 ea.

1955-58 CHAMPION 6-Cylinder
Total of all parts listed if purchased separately\$1826.90
Special kit price.....\$1737.00
—15% quantity discount. See page 4. ...\$260.55
801022R Your cost..... \$1476.45 ea.

1959-60 LARK & HAWK 6-cylinder

Total of all parts listed if purchased separately\$1949.95
Special kit price..... \$1853.00
—15% quantity discount. See page 4. ...\$277.95
801023R Your cost \$1575.05 ea.

1961-63 OHV 6-cylinder

Total of all parts listed if purchased separately\$1836.40
Special kit price..... \$1745.00
—15% quantity discount. See page 4. ...\$261.75
801024R Your cost \$1483.25 ea.

1939-47 CHAMPION 6-cylinder For car already equipped with insert type rod bearings. Excludes oil pump kit.

Total of all parts listed if purchased separately\$1839.15
Special kit price..... \$1747.00
—15% quantity discount. See page 4. ...\$262.05
801021X3R Your cost.. \$1484.95 ea.

1939-40 CHAMPION 6-cylinder w/cylinder head having casting #194777 Excludes oil pump kit.

Total of all parts listed if purchased separately\$2062.15
Special kit price..... \$1959.00
—15% quantity discount. See page 4. ...\$293.85
801021X1R Your cost . \$1665.15 ea.

Minor Rebuild Kits

Kit includes:

- Complete gasket kit
- Main bearings — choice of:
1939-54 std., .001, .010, .020 .030 .060 at extra cost) 1955-62 CRN/Partial Flow std., .001, .002, .010 (.020 or .030 at extra cost) 1963-64 Full Flow std., .010 (.020 or .030 at extra cost)
- Rod bearings — choice of:
1939-64 std., .001, .002, .005, .010, .020, .030, .040 .060
- Cam bearings std.
- Piston rings (Cast iron) — choice of: std. , +.020, +.030, +.040, +.060 (Except 1964)
- Timing gear
- Oil pump kit with 1½" gears
- Oil pressure relief valve, spring & washer
- 1 can aerosol engine enamel
- 1 silicone gasket sealer (tube)

1939-54 CHAMPION

Excludes oil pump kit.

Total of all parts listed if purchased separately\$809.25
Special kit price..... \$770.00
—10% quantity discount. See page 4. ...\$77.00
801025R Your cost \$693.00 ea.

1955-58 CHAMPION & 1959-60 LARK & HAWK

Total of all parts listed if purchased separately.\$772.25
Special kit price..... \$735.00
—10% quantity discount. See page 4. ...\$73.50
801026R Your cost \$661.50 ea.

1961-64 OHV

Total of all parts listed if purchased separately.\$704.55
Special kit price..... \$670.00
— 10% quantity discount. See page 4. ...\$67.00
801027R Your cost..... \$603.00 ea.

NOTE: WHEN ORDERING SPECIFY YEAR AND MODEL OF CAR, BEARING SIZE, PISTON & RING SIZE & PAINT COLOR. No SUBSTITUTIONS OR DELETIONS. CHROME RINGS AVAILABLE AT EXTRA COST.

Engine - Major & Minor Rebuild Kits for 6-cylinder

Major Rebuild Kits for 1955-64 V-8 259, 289

Kit includes:

- Complete gasket kit
- Main bearings choice of: std., -.010, -.020, .030
- Rod bearings choice of: std., -.001, -.002, -.010, -.020, .030
- Cam bearings std.
- Pistons — choice of most sizes
- Piston rings (Cast iron) — choice of: std., +.020, +.030, +.040, +.060
- Oil pump kit except for rebuild kit 801016

1955 259 V-8

Total of all parts listed if purchased separately.\$1900.80
Special kit price.....\$1806.00
 —15% quantity discount. See page 4. . \$270.90
801016R Your cost.....\$1535.10 ea.

1956-64 259 V-8

Total of all parts listed if purchased separately.\$1902.30
Special kit price.....\$1808.00
 —15% quantity discount. See page 4. . \$271.20
801017R
Your cost.....\$1536.80 ea.

1956-64 289 all V-8 except with jet thrust engine

Total of all parts listed if purchased separately.\$1902.30
Special kit price.....\$1808.00
 —15% quantity discount. See page 4. . \$271.20
801018R
Your cost.....\$1536.80 ea.

- Oil pressure relief valve, spring & washer
- 8 intake valve seats
- 8 exhaust valve guides
- 8 intake valve guides
- 16 valve springs
- 16 valve lifters
- 6 freeze plugs
- 1 camshaft plug
- 4 rocker arm end plugs
- 2 cans aerosol engine enamel

1963-64 AVANTI JET THRUST R-1

Total of all parts listed if purchased separately.\$1681.90
Special kit price.....\$1598.00

—15% quantity discount. See page 4.\$239.70

801076R
Your cost.....\$1358.30 ea.

1963-64 AVANTI JET THRUST R-2

Total of all parts listed if purchased separately.\$1707.40
Special kit price.....\$1623.00 ea.

—15% quantity discount. See page 4.\$243.45

801081R
Your cost.....\$1379.55 ea.

- 2 silicone gasket sealer (tube)
 - 1 lock plate
 - Crankshaft timing gear except Avanti
 - Camshaft timing gear (fiber) except Avanti
 - Crankshaft damper cushions (pair) except Avanti
 - 8 exhaust valves
 - 8 intake valves
 - 8 exhaust valve seats
- NOTE: Timing gears not included for R1 and R2 engines.

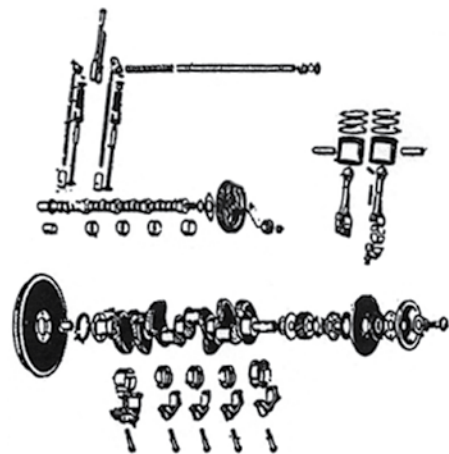

NOTE: When ordering specify year and model of car, bearing size, piston & ring size & paint color. No substitutions or deletions. Chrome rings are available at extra cost.

Minor Rebuild Kits for 1951-64 V-8 224, 232, 259, 289

Kit includes:

- Complete gasket kit
- Main bearings — choice of: std., -.010, -.020, .030
- Rod bearings — choice of: std., -.010, -.020, .010, .020, .030

1951-54 V-8 232

Total of all parts listed if purchased separately\$822.50
Special kit price.....\$782.00

—10% quantity discount. See page 4.\$78.20

801019R
Your cost.....\$703.80 ea.

- Cam bearings std.
- Piston rings (Cast iron) — choice of: std., +.020, +.030, +.040, +.060
- Timing gear all except Avanti & jet thrust
- Oil pump kit

1955-64 V-8 224, 259, 289

Total of all parts listed if purchased separately\$780.25
Special kit price.....\$742.00

—10% quantity discount. See page 4.\$74.20

801020R
Your cost.....\$667.80 ea.

- Oil pressure relief valve & washer
- Oil pressure relief valve spring
- 1 can aerosol engine enamel
- 1 silicone gasket sealer (tube)

1963-64 AVANTI JET THRUST R-1 OR R-2

Total of all parts listed if purchased separately\$647.00
Special kit price.....\$615.00

—10% quantity discount. See page 4.\$61.50

801091R Your cost.....\$553.50 ea.