

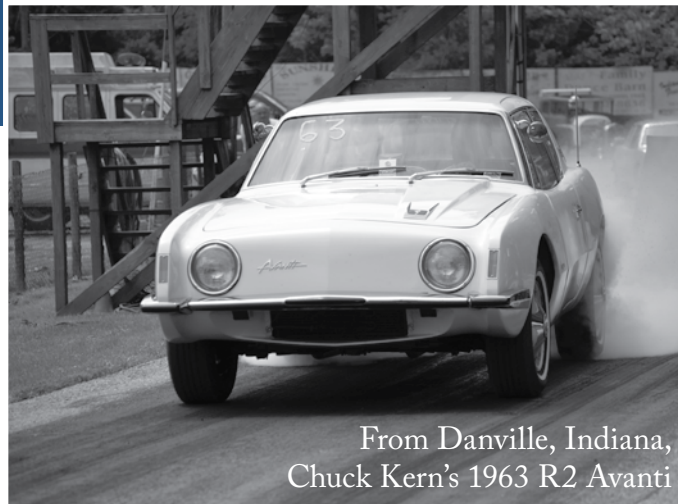

From Waco, Texas,  
Jim & Stephanie Baker's  
1963 Avanti & 1963 G. T. Hawk

**SUSPENSION, STEERING DRIVE-LINE & DIFFERENTIAL SECTION GLOSSARY**

*Steering Related Parts*..... 266-268  
*Pitman Arms, Bellcranks & Related Parts*..... 269  
*Reach Rods, Drag Links, or Reach Rod Ends*..... 269  
*Tie Rods & Related Parts*.....270, 285, 286  
*Stabilizer Bars & Related Parts*..... 271  
*Rear Axle Related Parts* .....272, 293-296  
*Front Wheel Bearings & Related Parts* ..... 273  
*Shock Absorbers & Related Parts*..... 274  
*Drive Shaft, Differential & Pinion Bearings* ..... 275  
*Leaf Springs & Related Parts* .....276-278  
*A-Arm Bushings, Pins & Bumpers* ..... 279  
*King Pins & Related Parts*..... 280  
*Steering Gear Related Parts*.....281-284  
*Drive Shaft Center Support Related Parts* ..... 287  
*Front Axle Related Parts*..... 288-292  
*“Dana” Rear Axle Related Parts* .....293-294, 296  
*“Twin Traction” Axle Related Parts* ..... 295



From Danville, Indiana,  
Chuck Kern's 1963 R2 Avanti



From Evans City, Pennsylvania,  
Bill & Elaina Lindner's 1961 Lark Regal Convertible



## REBUILT POWER STEERING PUMP

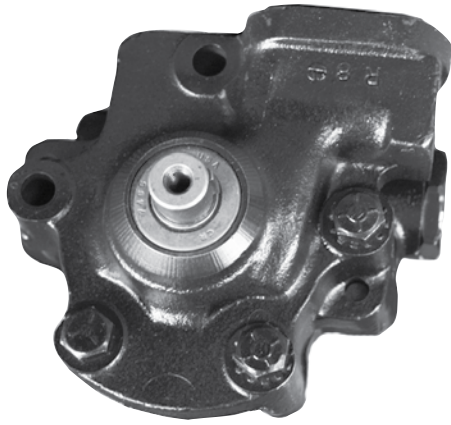

**1558689**  
Eaton pump without reservoir. 1958-64 car all models including 1963-64 Avanti.  
..... **\$210.00 ex.**

NOTE: THIS IS AN EXCHANGE. WE MUST HAVE YOUR OLD, REBUILDABLE, PUMP BEFORE YOUR NEW PUMP WILL SHIP. **Please send bare pump only. No brackets or tank.** THERE WILL BE AN ADDITIONAL CHARGE IF DISASSEMBLY IS REQUIRED.

## RUBBER BUSHINGS



**1546133** Rubber bushing ram to bracket. 1958-66 car, all models & 1963-85 Avanti. Eaton/Bendix. Takes 2. .... **\$3.50 ea.**

## PUMP MOUNTING BOLTS

**1547363**  
1963-64 Avanti & 1958-64 car, all models except 1958 Packard Hawk and 1959 V-8 Hawk. .... **\$18.00 ea.**

**1547364** 1963-64 Avanti & 1958-64 car, all models except 1958 Packard Hawk and 1959 V-8 Hawk. .... **\$18.00 ea.**

## PUMP FRONT SHAFT SEALS

**534684** 1953-55 car, all models. Vicker's IG3-168-031 type "A" pump. Saginaw. .... No Stock  
**535527** 1954-56 car, all models. C-R 5681410 type "A" pump. Saginaw. .... **\$12.00 ea.**

**1541300** 1955-57 cars without a/c, type "B" or "C" pump. Saginaw. .... **\$16.00 ea.**  
**1543842** 1957-58 cars with a/c, type "E" pump. Saginaw. .... **\$15.00 ea.**  
**1546109** 1958 cars with type "D" pump. Saginaw. .... **\$15.00 ea.**  
**1558693** 1959-60 V-8. 1961-64 all models & 1963-64 Avanti. Eaton/Bendix. .... **\$6.00 ea.**



## POWER STEERING HOSES

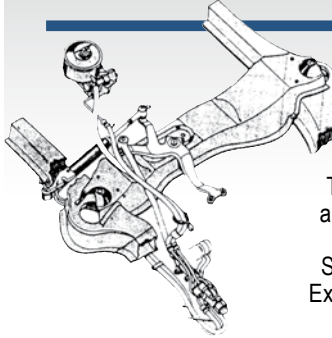

Note: These Hoses are for Bendix or Eaton Systems only. Except 534666 is Saginaw.

### A) PRESSURE HOSES

**534666** 1953-54 Champion & Commander All except C & K. Saginaw. .... **\$44.50 ea.**  
**800703** 1984-85 Avanti. .... **\$65.00 ea.**  
**1547339** 1959-63 Lark & Hawk. **\$42.00 ea.**  
**1561481** 1964 all models & 1963-64 Avanti. .... **\$48.00 ea.**  
**1563475** 1965-66 V-8 all models & 1966-83 Avanti. .... **\$46.75 ea.**

### B) RETURN HOSES

**1544047** 1959-63 Lark & Hawk. .... **\$26.00 ea.**  
**1544050** 1958 Champion. .... **\$27.00 ea.**  
**1559778** 1964-66 Lark & 1963-85 Avanti. .... **\$36.00 ea.**

### C) RIGHT TURN HOSES

**1544020** 1958-60 Hawk. .... **\$49.90 ea.**  
**1544054** 1958-60 Sedan includes Lark. .... **\$49.00 ea.**  
**1551342** 1961-63 Hawk. .... **\$49.00 ea.**  
**1561482** 1961-66 Lark & 1963-85 Avanti. .... **\$34.00 ea.**  
**1561483** 1964 Hawk. .... **\$49.00 ea.**

### D) LEFT TURN HOSES

**1544021** 1958-60 Hawk. .... **\$49.00 ea.**  
**1544051** 1958-60 Sedan includes Lark. .... **\$49.00 ea.**  
**1551343** 1961-63 Hawk. .... **\$49.00 ea.**  
**1561484** 1961-66 Lark & 1963-85 Avanti. .... **\$36.00 ea.**  
**1561485** 1964 Hawk. .... **\$49.00 ea.**

NOTE: NONE OF THESE HOSES WILL FIT 1958 PACKARD CAR OR 1959 V-8 HAWK.

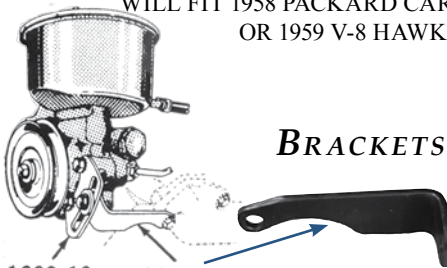

## BRACKETS

**1309-10** **1309-11**  
**NEW Listing - 1549567P** Bracket illustrated on left, power steering brace. 1958-64 Sedan, 1960-64 Hawk & 1963-64 Avanti. Eaton/Bendix. (1309-10)..... **\$26.00 ea.**  
**1549568P** Bracket illustrated on right and pictured, power steering brace. 1958-64 Sedan, 1960-64 Hawk & 1963-64 Avanti. Eaton/Bendix. (1309-11)..... **\$26.00 ea.**

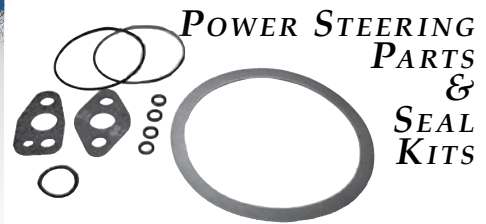

**534712** Pump seal kit. 1955 all models and 1956 with type "A" pump. Saginaw. .... **\$32.00 ea.**

**535512** Pump repair kit, Saginaw. 1955-56 with type "A" or "B" pump. Includes bearing ring & rotor vane kit. .... **\$165.00 ea.**

**801352** Control valve seal kit for Saginaw control valve in all 1953-57 car, 1958 Packard Hawk & 1959 V8 Hawk. Includes all seals for rebuild including seals only on factory seal kit 534665, 534641 power cylinder oil seal, 534655 top cover seal, & 534604 shaft and worm seal. Takes 2. .... **\$99.95 ea.**

**1541294** Gasket set for Saginaw power steering pump, 1956 & 1957 car with type "B" power steering pump. .... **\$45.00 ea.**

**1543105** Gasket set for Saginaw power steering pump for 1957-58 car with type "C" or type "D" power steering pump. .... **\$22.00 ea.**

**1543843** Pump repair kit, Saginaw, all 1957 cars with AC & early 1958. .... **\$168.00 ea.**

**1543844** Gasket set for Saginaw pump, 1957-58 car with AC & early 1958 car. .... **\$26.00 ea.**

**1543903** Seal. Control valve to Pitman arm. 1958-66 all models & 1963-85 Avanti. Eaton/Bendix. .... **\$2.00 ea.**

**1545332** Control valve seal kit. 1958-66 & 1963-85 Avanti. The control valve connects under the steering Pitman arm. It has 2 hoses going to the pump, and 2 going to the ram. Eaton/Bendix. .... **\$18.00 ea.**

**1553403** Seal. Control valve to Pitman arm. 1958-66 all models & 1963-85 Avanti. Eaton/Bendix. .... **\$2.00 ea.**

**1545332** Control valve seal kit. 1958-66 & 1963-85 Avanti. The control valve connects under the steering Pitman arm. It has 2 hoses going to the pump, and 2 going to the ram. Eaton/Bendix. .... **\$18.00 ea.**

**1553403** Seal. Control valve to Pitman arm. 1958-66 all models & 1963-85 Avanti. Eaton/Bendix. .... **\$2.00 ea.**

**1545332** Control valve seal kit. 1958-66 & 1963-85 Avanti. The control valve connects under the steering Pitman arm. It has 2 hoses going to the pump, and 2 going to the ram. Eaton/Bendix. .... **\$18.00 ea.**

**1553403** Seal. Control valve to Pitman arm. 1958-66 all models & 1963-85 Avanti. Eaton/Bendix. .... **\$2.00 ea.**

**1545332** Control valve seal kit. 1958-66 & 1963-85 Avanti. The control valve connects under the steering Pitman arm. It has 2 hoses going to the pump, and 2 going to the ram. Eaton/Bendix. .... **\$18.00 ea.**

**1553403** Seal. Control valve to Pitman arm. 1958-66 all models & 1963-85 Avanti. Eaton/Bendix. .... **\$2.00 ea.**

**1545332** Control valve seal kit. 1958-66 & 1963-85 Avanti. The control valve connects under the steering Pitman arm. It has 2 hoses going to the pump, and 2 going to the ram. Eaton/Bendix. .... **\$18.00 ea.**

**1553403** Seal. Control valve to Pitman arm. 1958-66 all models & 1963-85 Avanti. Eaton/Bendix. .... **\$2.00 ea.**

**1545332** Control valve seal kit. 1958-66 & 1963-85 Avanti. The control valve connects under the steering Pitman arm. It has 2 hoses going to the pump, and 2 going to the ram. Eaton/Bendix. .... **\$18.00 ea.**

**1553403** Seal. Control valve to Pitman arm. 1958-66 all models & 1963-85 Avanti. Eaton/Bendix. .... **\$2.00 ea.**

**1545332** Control valve seal kit. 1958-66 & 1963-85 Avanti. The control valve connects under the steering Pitman arm. It has 2 hoses going to the pump, and 2 going to the ram. Eaton/Bendix. .... **\$18.00 ea.**

**1553403** Seal. Control valve to Pitman arm. 1958-66 all models & 1963-85 Avanti. Eaton/Bendix. .... **\$2.00 ea.**

**1545332** Control valve seal kit. 1958-66 & 1963-85 Avanti. The control valve connects under the steering Pitman arm. It has 2 hoses going to the pump, and 2 going to the ram. Eaton/Bendix. .... **\$18.00 ea.**

**1553403** Seal. Control valve to Pitman arm. 1958-66 all models & 1963-85 Avanti. Eaton/Bendix. .... **\$2.00 ea.**

**1558689X1** Pump seal rebuild kit. Eaton/Bendix. 1958-64 car & 1963-64 Avanti. .... **\$18.50 ea.**

**1558689X1** Pump seal rebuild kit. Eaton/Bendix. 1958-64 car & 1963-64 Avanti. .... **\$18.50 ea.**

**1558689X1** Pump seal rebuild kit. Eaton/Bendix. 1958-64 car & 1963-64 Avanti. .... **\$18.50 ea.**

**1558689X1** Pump seal rebuild kit. Eaton/Bendix. 1958-64 car & 1963-64 Avanti. .... **\$18.50 ea.**

**1558689X1** Pump seal rebuild kit. Eaton/Bendix. 1958-64 car & 1963-64 Avanti. .... **\$18.50 ea.**

**1558689X1** Pump seal rebuild kit. Eaton/Bendix. 1958-64 car & 1963-64 Avanti. .... **\$18.50 ea.**

**1558689X1** Pump seal rebuild kit. Eaton/Bendix. 1958-64 car & 1963-64 Avanti. .... **\$18.50 ea.**

\*NOTE: TO DETERMINE THE TYPE PUMP YOU HAVE - EITHER "A", "B", "C", "D"- REFER TO THE FACTORY CHASSIS MANUAL FOR YOUR CAR.

# POWER STEERING REPAIR KITS

- 1 pump seal kit, Except 1965-66 Lark or 1966-85 Avanti Power steering repair kits
- 1 control valve seal kit

- 1 ram seal kit
- 1 pressure hose
- 1 return hose

- 1 right turn hose
- 1 left turn hose

NOTE: WHEN ORDERING SPECIFY YEAR AND MODEL OF CAR. NO SUBSTITUTIONS OR DELETIONS. ALL KITS ARE BENDIX/EATON.

## 1959-60 LARK

**Total of all parts listed if purchased separately.** .....\$220.00

**801044R**  
Special package price. ..\$209.00 ea.

## 1962-63 HAWK

**Total of all parts listed if purchased separately.** .....\$220.00

**801047R**  
Special package price. ..\$209.00 ea.

## 1965-66 LARK & 1966-83 AVANTI

**Total of all parts listed if purchased separately.** ..... \$184.75

**801077R**  
Special package price. .. \$175.50 ea.

## 1960-61 HAWK

**Total of all parts listed if purchased separately.** .....\$220.00

**801045R**  
Special package price. ..\$209.00 ea.

## 1964 HAWK

**Total of all parts listed if purchased separately.** .....\$236.00

**801048R**  
Special package price. ..\$224.20 ea.

## 1984-85 AVANTI

**Total of all parts listed if purchased separately.** .....\$206.50

**801078R**  
Special package price. ..\$196.00 ea.

## 1961-63 LARK

**Total of all parts listed if purchased separately.** .....\$192.00

**801046R**  
Special package price. ..\$182.40 ea.

## 1964 LARK & 1963-64 AVANTI

**Total of all parts listed if purchased separately.** .....\$208.00

**801049R**  
Special package price. ...\$197.60 ea.

## STEERING WHEEL

**1551067** Black. 1957-60 car. Truck: 4 & 5 speed 1960-64 Champ. ....\$360.00 ea.

**1551574** Black. 1962-64 Hawk. Truck: 1962-64 Champ except 4 & 5 speed. ....\$360.00 ea.



## STEERING WHEEL INSERT

**1556051** Plastic steering wheel insert 1963-70 Avanti. Takes 2. .... 12.00 ea.

## AVANTI STEERING POST FASTENER

**1350271** Adheres to steering post collar & seal to firewall. Takes 3. ....\$3.50 ea.

## STEERING COLUMN LOWER BUSHING

**1559515** 1963-early Avanti II without adjustable column. ....\$26.50 ea.

## CONTROL VALVE SEALS

For 1953-57 all, 1958 Packard & 1959 Hawk with Saginaw.

**534616** Sector shaft seal. Pictured, above - left. ....\$6.00 ea.

**534641** Oil seal, power cylinder rod. ....\$10.00 ea.

**534655** Oil seal, control valve top cover. Pictured, above - right. ....\$13.00 ea.



## QUICK STEERING ARM

**800355**

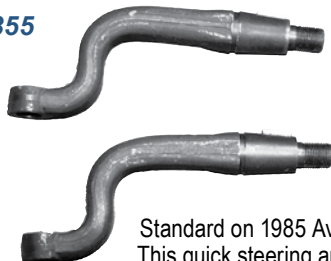

Standard on 1985 Avanti. This quick steering arm will work on all 1951-66

Studebaker cars including Lark & Hawk and all 1963 - 85 Avanti. Easily installed, reduces steering time. Recommended for power steering equipped cars only. ....\$125.00 pr.

## STEERING IDLER ARMS & BUSHINGS

**191833** All 1938 cars & early 1939 Commander. ....\$32.00 ea.

**196593** Late 1939 Commander & all 1939 Coupe Express. Pictured, above. ....\$28.00 ea.

**197650** 1939-early 1940 Champion. ....\$24.00 ea.

**197918** All 1940 Commander & President. ....\$28.00 ea.

**198074** Late 1940 Champion...\$32.00 ea.

**513502** 1939-40 Champion using type "A" mounting bracket. See page 412 in 1934-46 Chassis Parts book. Also late 1941-46 Champion. ....\$22.00 ea.

**513508** Late 1941 & all 1942 Commander & President. ....\$24.00 ea.

**513519** Early 1941 Commander & President. ....\$22.00 ea.

**801259R** Pin & bushing kit for idler arm on 1938-46 cars. State year, model and serial # when ordering. ....\$38.00 ea.

**1696946** Bushing, idler arm. Truck: 8E 5, 7, 10, 12. ....\$15.00 ea.

## NOS STEERING WHEELS

**We have a limited stock of new steering wheels for 1957-66 cars. Please inquire at (317) 462-3124**



## Steering Column Seals

**284956** 1947-49 Champion. Pictured right.  
..... \$55.00 ea.

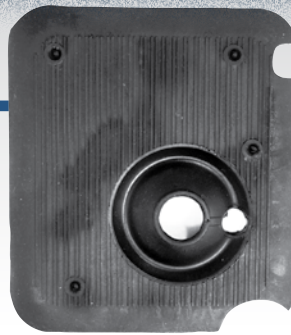

**291068**  
1950 Champion.  
..... \$55.00 ea.

**284956**

**293087**  
1951-52 Champion &  
Commander.  
..... \$65.00 ea.



**306906**  
1954-57 Sedan  
without power  
steering.  
... \$75.00 ea.

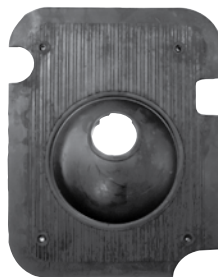

**306912X1**  
1954-59 C & K  
including Hawk,  
with saginaw power  
steering.  
..... \$85.00 ea.

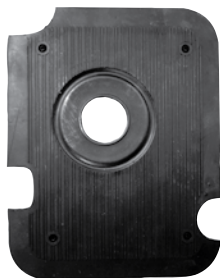

**1320181X1**  
1953-57 C & K,  
including Hawk. 1958-  
64 Hawk, all models.  
..... \$80.00 ea.

**1324127**  
1957- 64 Hawk.  
Fits below seals  
1320181X1 & 306912X1.  
..... \$22.00 ea.



**1332466 &  
1332478**  
1959- 60 Lark.  
..... \$22.00 set



**1350434**  
1963- early  
Avanti II.  
..... \$3.50 ea.

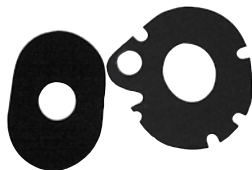

**1339323 &  
1339390**  
1961-66 Lark.  
..... \$22.00 set

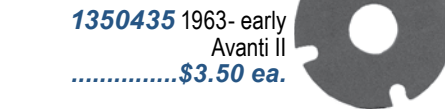

**1350435** 1963- early  
Avanti II  
..... \$3.50 ea.

**1656311 &  
1656308**  
1963-64 Champ.  
..... \$22.00 set



**1655725 &  
1655722**  
1961- 62 Champ.  
..... \$22.00 set



**1655229 &  
1655226**  
1960 Champ.  
..... \$22.00 set



## STEERING POST & CAM PARTS

**G145641** 1934-64 all models with  
"TA," "TL," or "SL" steering gear box.  
Truck: 1942-56 M5-M17 & 2R5-2E2  
with T12, TA12, T14, TA14..... \$6.25 set/25

**801551** Stud, Cam  
lever shaft 1963-71 Avanti,  
Truck: 8E 5,7,10,12.  
..... \$49.95 ea.



**1696791** Steering gear post & cam less  
bearings & cups. Truck: 8E 5, 7, 10, 12 (Gear  
SE 54)..... \$160.00 ea.

## STEERING WHEEL PULLER



**J-5473** Heavy duty tool to easily remove  
your steering wheel from the steering shaft.  
..... \$15.00 ea.

## STEERING BOX GREASE

**801651** Semi- Fluid Steering  
Box Grease is an ultra tough,  
aluminum complex grease  
designed to lubricate manual Ross  
TA/TL (4-bolt side cover) steering  
boxes. .... \$24.50 ea.

NOTE: ONE 12 OZ. BOTTLE IS  
GENERALLY ENOUGH TO FILL AN  
EMPTY STEERING BOX. IT MAY ALSO  
BE USED TO TOP OFF A PARTIALLY  
FILLED BOX



## STEERING BOX SEALS

**190276** Sector shaft seal.  
1957-64 car with type "SL"  
box & 1963-75 Avanti. Truck: 2R-6E, 13-17,  
28,38, 40 with TA14 &TA54, 7E-8E all with TA14,  
TA54. .... \$17.50 ea.

**530916** Side cover gasket. 1951-60 with "TL"  
type box. .... \$4.50 ea.

**679257** Shaft seal. 1951-60 car with type  
"TA" or "TL" box. Truck: 2R-3E: 5, 6, 7, 10, 11,  
12 & 3E-4E 1-12 with TA 12. .... \$8.00 ea.

**1542670** Steering box cover seal. Type SL  
1957 - 1964 Hawk ..... \$4.95 ea.

**1552088** Shaft seal. 1961-64 car with "S"  
type box ..... \$11.25 ea.

**1557623** Housing cover gasket. 1963-75  
Avanti..... \$4.00 ea.



## PITMAN ARMS



- 532561** 1953-54 C & K without power steering. .... **\$38.00 ea.**  
**665015** Truck: M15-M17. Pictured. .... **\$30.80 ea.**  
**679258** 2R-4E 5, 10, TA 12. .. **\$42.35 ea.**  
**679274** 3R-7E, 13, 14, 15. TA14. .... **\$52.80 ea.**  
**1553208** 1961-66 6-cylinder with SL box & 1961-66 V-8. .... **\$42.35 ea.**  
**1553480** 1961-66 Lark with power steering. **\$48.00 ea.**

## PITMAN ARM PULLER

**800809** Easily removes Pitman arm. ..**\$45.00 ea.**



**NOTE: May not function with engine in place on some vehicles.**

## Bellcrank

### REBUILT

#### 800536

Rebuilt bellcrank. 1951-66 car all models & 1967-85 Avanti. Completely assembled with new pin & bearings. Superior bearings replace original bushings on some models. .... **\$125.00 ex.**  
**Plus \$150.00 Refundable core charge.** .... **\$150.00 ea.**

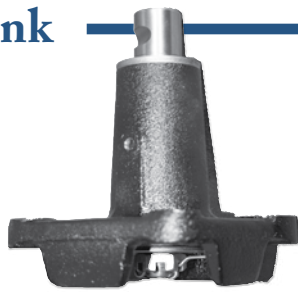

**G271288** Extra long zerk fitting for 800536 bellcrank. .... **\$3.50 ea.**



**Note: We have more Drag link assemblies for the larger trucks. Please inquire.**

## CENTER BELLCRANK PARTS

- 700001** Rebuild kit. 1951-62 car, all models & early 1963 car. Includes new shaft & 2 bearings. .... **\$65.00 ea.**  
**700002** Rebuild kit. Late 1963-66 car, all models & 1967-85 Avanti. Includes new shaft & 2 bushings. .... **\$65.00 ea.**  
**525002** .010 shim.... **\$1.50 ea.**  
**525004** .015 shim.... **\$1.50 ea.**  
**525005** .020 shim.... **\$1.50 ea.**  
**525007** Shaft seal to go with 525013 bearing. .... **\$2.00 ea.**  
**525013** Bearing. 1950 Commander & 1951 to early 1963 car, all models. Takes 2. .... **\$11.75 ea.**  
**1554379** Bushing. Late 1963-66 car all models & 1967-85 Avanti. Takes 2. .... **\$12.50 ea.**  
**1554380** Shaft seal to go with 1554379 bushing. .... **\$2.00 ea.**



## Reach Rod or Drag Link

### REACH ROD ENDS

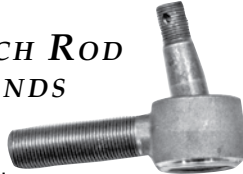

- 520111** Truck: 1949-56 1/2 & 3/4 ton. 1st type with left hand thread. .... **\$90.00 ea.**  
**681512** Truck: 1949-56. All big trucks. .... **\$52.00 ea.**  
**1689384** Truck: 3E-6E 1-14 & 7E 5, 7, 10, 12, 13, 15. 2nd type with right hand thread. Pictured. .... **\$42.60 ea.**

- 520115** Drag link. 1947-49 Commander. Pictured above, right. .... **\$52.00 ea.**  
**526567** 1950 Commander. .... **\$52.00 ea.**  
**530325** All 1951-52 car. .... **\$54.00 ea.**  
**533059** All 1953-54 Sedan & Station Wagon without power steering. .... call  
**1542004** 1958-66 Sedan & Lark & 1963-85 Avanti with manual steering. NOS. .... **\$145.00 ea.**



**1561778** 1958 Sedan, 1959-66 Lark & 1963-85 Avanti with power steering. .... **\$85.00 ea.**



- NEW Listing - 1542005** Drag link for all the following with manual steering, 1957-58 Hawk V-8 and 1959-64 Hawk except early 1959 6-cylinder. .... **\$175.00 ea.**  
**NEW Listing - 1689414** Truck: 1960-64 5E -8E with power steering. 13". **\$225.00 ea.**  
**NEW Listing - 1692249** Truck: 1960 - early 1962 3/4 ton models 10, 11, 12. .... **\$250.00 ea.**

**NEW Listing - 1546219** 1958-63 Hawk with Bendix power steering. .... **\$105.00 ea.**  
**1561779** 1964 Hawk with Bendix power steering. .... **\$125.00 ea.**

**NEW Listing - 1695660** Truck: Late 1962 1/2 ton models 5 & 7 (After serial #'s E5 - 135, 294 or E7 - 18,075)... **\$250.00 ea.**  
**NEW Listing - 1695704** Truck: Late 1962 3/4 ton models 10 & 12 after serial # E10 - 39,675 or E12 - 5646. .... **\$250.00 ea.**

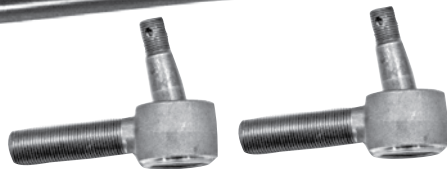

**1689408** 1949-59 1/2 & 3/4 ton trucks. .... **\$250.00 ea.**

- 666252** M5 pickup before serial number M5 3,238. Pictured below. .... **\$75.00 ea.**  
**666822** M5 pickup after serial number M5 3,238. .... **\$225.00 ea.**

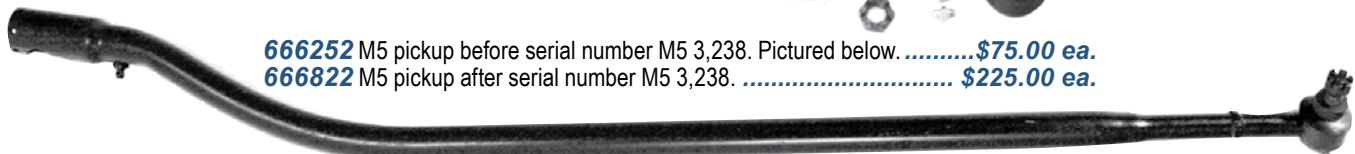

# Tie Rod

## Tie Rod Parts

**182898** Tie rod assembly. Short side. 1935 Dictator 2A. Pictured, right. .... **\$125.00 ea.**

**184173** Tie rod end, right. Late 1935 Dictator 2A, 1935 Commander 8 & President, 1936 Dictator 4A, 1937 Dictator 6A & President. .... **\$45.00 ea.**

**184174** Tie rod end, left. Same application as above. .... Call

**193383** Tie rod assembly with ends, right side. 1938 car & early 1939 Commander. ... Call

**193384** Tie rod assembly with ends, left side. 1938 car & early 1939 Commander. ... Call

**198180** Tie rod assembly, right or left side. 1939-46 Champion. .... **\$105.00 ea.**

**199203** Tie rod end, left. 1934-37 Dictator A, 1A, 3A, 5A & Coupe Express. .... **\$45.00 ea.**

**199204** Tie rod end, right. 1934-37 Dictator A, 1A, 3A, 5A & Coupe Express. .... **\$45.00 ea.**

**199207** Tie rod end, outer right or inner left. Late 1940 & all 1941-46 Champion. .... **\$40.00 ea.**

**199208** Tie rod end, inner right or outer left. Late 1940 & all 1941-46 Champion. .... **\$80.00 ea.**

**199212** Tie rod end. Left side, spring loaded. 1937 Dictator 6A & President. .... **\$80.00 ea.**

**199213** Tie rod end. Right side, spring loaded. 1937 Dictator 6A & President. .... **\$80.00 ea.**

**513301** Tie rod assembly, right side. 1941-42 Commander & President. .... **\$135.00 ea.**

**513302** Tie rod assembly, left side. 1941-42 Commander & President. .... **\$135.00 ea.**

**519607** Tie rod assembly, right or left side. 1947-49 Champion. .... **\$135.00 ea.**

**519608** Tie rod end. Outer left/inner right. 1947-49 Champion. .... **\$80.00 ea.**

..... Substitute for 199208 or 520439

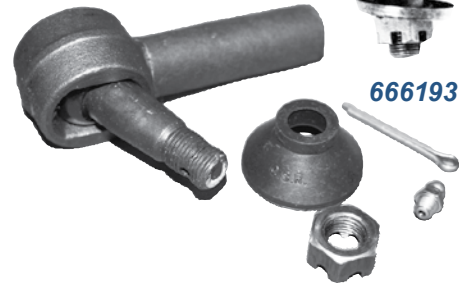

**519609** Tie rod end. Outer right/inner left 1947-49 Champion & inner right or inner left 1950 Champion use 199208. .... **\$80.00 ea.**

**520108** Tie rod assembly, right side. 1947-49 Commander. .... **\$135.00 ea.**

**520109** Tie rod assembly, left side. 1947-49 Commander. .... **\$135.00 ea.**

**520110** Tie rod end, inner right. Late 1939 & all 1940-42 Commander & President. .... Use 520111

**520111** Tie rod end, inner left. Early 1939 & all 1940-42 Commander & President. Also outer right for 1947-49 Commander. .... **\$90.00 ea.**

**520112** Tie rod end. Outer right end for late 1939 & all 1940-42 Commander & President. Also inner right for 1947-49 Commander. .... **\$45.00 ea.**

**520113** Tie rod end. Outer left for late 1939 & all 1940-42 Commander & President. Also inner left for 1947-49 Commander. .... **\$45.00 ea.**

**526570** Tie rod end. Inner left outer right for 1950 Commander. .... **\$45.00 ea.**

**526571** Tie rod end, outer left inner right. 1950 Commander. .... **\$45.00 ea.**

**527977** Tie rod with clamps. 1951-62 car. 21 5/16" long. .... **\$41.50 ea.**



**530202** Tie rod rubber boot. 1951-66 all models. Duplicate of original through 1963. .... **\$2.50 ea.**

**530203** Tie rod end, outer right & inner left. 1951-early 62 car, all models. Right hand thread. .... **\$45.00 ea.**

**530204** Tie rod end, inner right & outer left. 1951-early 62 car, all models. Late 1962-1963 inner. Left hand thread. .... **\$45.00 ea.**

**664824** Right tie rod end. Truck: 1941-48 M16 & M17. Early 2R16 & 2R17. .... **\$45.00 ea.**

**666007** Left tie rod end. Truck: 1941-48 M16 & M17. Early 2R 16 & 2R 17. .... **\$45.00 ea.**

**666193** Right tie rod end. Truck: 1941-62 1/2 ton & all truck models 12-15 1949-64. Pictured above. .... **\$38.00 ea.**

**666194** Left tie rod end. Truck: 1941-62 1/2 ton & all truck models 12-15 1949-64. .... **\$49.50 ea.**

**666292** Right rod end. Truck: M15-M15A. .... **\$40.00 ea.**

**666293** Left tie rod end. Truck: M15-M15A. .... **\$45.00 ea.**

**684163** Right tie rod end. Truck: late 2R16 & 2R17. 1954-64 models 25-45. .... **\$55.00 ea.**

**684164** Left tie rod end. Truck: late 2R16 & 2R17. 1954-64 models 25-45. .... **\$55.00 ea.**

**1553703** Rod with clamps. Late 1962-66 car all models & 1963-85 Avanti... **\$19.50 ea.**

**1554236** Outer tie rod end, long. Late 1962-63 car, all models. .... **\$120.00 ea.**

**1561767** Outer tie rod end, long. 1964-66 car, all models & 1964-85 Avanti. . **\$89.00 ea.**

**1561769** Inner tie rod end, short. 1964-66 car all models & 1964-85 Avanti. . **\$46.50 ea.**

**1554236**



## Auxiliary Tie Rod Assemblies & Ends For cars with 3-tie rod setup.



**193134** Assembly. All 1938-39 cars except Champion. .... **\$103.80 ea.**

**197157** Assembly. 1939-40 Champion. .... **\$95.00 ea.**

**198579** Assembly. 1940-42 Commander & President. .... **\$65.00 ea.**

**198588** Assembly. 1941-46 Champion. Pictured above. .... **\$65.00 ea.**

**199207** Left end, only. All 1939 & early 1940 Champion. .... **\$40.00 ea.**

**199208** Right end, only. All 1939 & early 1940 Champion. .... **\$80.00 ea.**

**520345** Left end, only. 1938-49 Commander & President. .... **\$38.00 ea.**

**520346** Right end, only. 1938-49 Commander & President. .... **\$45.00 ea.**

**520438** Right end, only. 1947-49 Champion. .... **\$25.00 ea.**

**520439** Left end, only. 1947-49 Champion. .... **\$80.00 ea.**



## FRONT STABILIZER BAR RELATED PARTS

**419932** Link bushing for 1545231. 1958-early 1963 car and Avanti to #1815..... **\$4.00 ea.**

**522518** Rubber bushing. 1950 Champion & Commander 1947-50. Takes 2..... **\$10.00 ea.**

**522673** Grommet, control arm stabilizer shaft link. 1947-50 Commander & 1950 Champion. Takes 8. .... **\$3.00 ea.**

**529391** Retainer for sway bar bushings on all 1951-66 cars. Takes 4. Used. .... **\$20.00 ea.**

**529392** Rubber bushing. 1951-57 car all models. Takes 4. . **\$9.50 ea.**

**801362** Front stabilizer bar 1" Diameter. 1951-66 cars. Comes with new bushings. Must use 1963-66 mounting hardware. Not original but a nice addition for greater stability. .... **\$299.00 ea.**

**1539470** Front stabilizer bar. 1961-66 6-cylinder. .... **\$60.00 ea.**

**1539472** Rubber bushing. 1958-66 car all models & 1963-83 Avanti. Takes 4. **\$9.50 ea.**



**1545231** Center link assembly. 1958- early 1963 car & Avanti to #1815. Includes top bushing & sleeve. Lower section. **\$35.00 ea.**

**1558373** Bracket to frame. 1963-66 Lark, Hawk & 1963-85 Avanti. .... **\$46.50 ea.**

**1702181** Rubber bushing. 1984-85 Avanti with 1" bar. Takes 4. .... **\$16.50 ea.**

**1702280** Rubber bushing. 1984-85 Avanti with 7/8" bar. Takes 4. .... **\$12.50 ea.**

## HEAVY DUTY STABILIZER BAR CONVERSION KIT

**800710** Provides firmer handling and improves suspension. Kit includes 1" front sway bar, 3/4" rear sway bar and all necessary brackets and bushings. 1963-85 Avanti ..... **\$530.00 kit**

## Rear Stabilizer Bar Kits

Already assembled - Reduces lean on corners & improves ride. All 1953-66 Sedan and 1953-64 C & K. Includes Hawk.\*

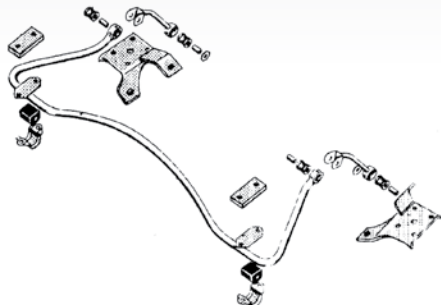

**801447** 1953-58 car, all models. Does not include lower spring plate. .... **\$375.00/kit**

**801448** 1959-62 Lark. Includes lower spring plate. .... **\$485.00/kit**

**801820** 1959-62 Hawk. Includes lower spring plate. .... **\$485.00/kit**

**801821** 1963-66 Lark. Includes lower spring plate. .... **\$485.00/kit**

**801822** 1963-66 Hawk. Includes lower spring plate. .... **\$485.00/kit**

\*Kit comes complete with all mounting hardware.

## Rear Traction Bar Kits

Add traction bars (radius rods) to your Studebaker to eliminate wheel hop and spring wrap-up under hard acceleration.

### Kit includes

- **800537** rear axle bracket, left
- **800538** rear axle bracket, right
- **800539** or **800540** frame bracket (2)
- **1557384** or **1560526-7** traction bar (2)
- **1557385** rubber bushing (4)
- **1557388** bushing spacer (2)

### 1953-66 SEDAN (Includes Lark)

**Total of all parts if purchased separately:** ..... **\$316.00**

**800786 Special package price** ..... **\$290.00/kit**

### 1953-64 C & K (Includes Hawk)

**Total of all parts if purchased separately:** ..... **\$281.00**

**801446 Special package price** ..... **\$260.00/kit**

## REAR STABILIZER BAR Related Parts 1947-64

**198685** Inner bushing. 1947-64 all models except Avanti. Link bushing. Takes 4. .... **\$4.50 ea.**

**522518** Outer bushing. 1947-64 all models & 1963-85 Avanti Takes 2. .... **\$10.00 ea.**

**529392** Inner bushing. 1963-85 Avanti. Takes 2. .... **\$9.50 ea.**

**1554004** Shaft link grommet. 1963-85 Avanti. Takes 4. .... **\$3.50 ea.**

**1557476** Outer bushing retainer. 1947-64 all models & 1963-85 Avanti. Takes 2. .... **\$19.50 ea.**

## REAR TRACTION BAR RELATED PARTS

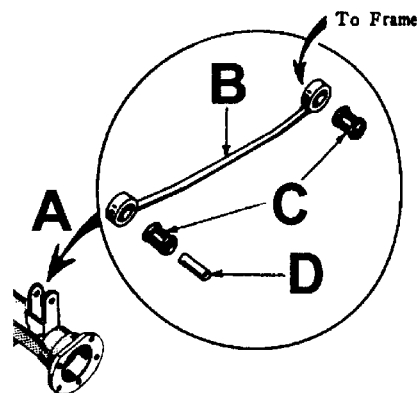

**(A) 800537** Rear axle bracket, left. 1963-64 Lark, Hawk & 1963-85 Avanti. .... **\$40.00 ea.**

**(A) 800538** Rear axle bracket, right. 1963-64 Lark, Hawk & 1963-85 Avanti. .... **\$40.00 ea.**

**800539** Frame bracket. 1963-64 Hawk & 1963-85 Avanti. .... **\$40.00 ea.**

**800540** Frame bracket. 1963-64 Lark. .... **\$40.00 ea.**

**(B) 1557384** Traction bar. 1963-85 Avanti & Hawk. .... **\$45.00 ea.**

**(B) 1560526** Traction bar, right. 1963-64 Lark. .... **\$62.50 ea.**

**(B) 1560527** Traction bar, left. 1963-64 Lark. .... **\$62.50 ea.**

**(C) 1557385** Rubber bushing, takes 4. 1963-64 Lark, Hawk & 1963-85 Avanti. .... **\$5.00 ea.**

**(D) 1557388** Bushing spacer. 1963-64 Lark, Hawk & 1963-85 Avanti. Takes 2. .... **\$5.50 ea.**

## REAR AXLE SHAFT BEARING PARTS

- 127013** Cup. 1928-29 Dictator "GE" ..... **\$28.00 ea.**
- 130408** Cup. 1929-30 Dictator 6 & 8, 1931-33 Studebaker 6, 1932 Rockne "41", 1931-32 Dictator 8 & 1933 Commander 8. **\$16.00 ea.**
- 165048** Cup. 1932-33 Rockne 65 & 67. 1934-37 Dictator 6. .... **\$27.00 ea.**
- 165167** Cup. 1929 Commander 6, 1929-30 Dictator 6 Delivery. All 1929-32 Dictator 8 plus 1933 President, 1939-50 Champion & 1951-64 car, all models & 1963-64 Avanti with tapered axle. Truck: 2E-4E 10, 11, 12. Takes 2. .... **\$13.00 ea.**
- 174330** Bearing. 1932 Rockne "41", 1932-33 Studebaker 6, 1932 Dictator 8, 1933 Commander 8. .... **\$29.00 ea.**
- 187627** Cup. 1936-37 President. **\$26.00 ea.**
- 192238** Cup. 1938-50 Commander & Coupe Express. 1938-42 President. Truck: M5 & 2R-2E 5, 6, 7 & 3E-6E 1-3, 5-7 & 7E-8E 5-7. .... **\$18.50 ea.**
- 192239** Bearing. 1938-50 Commander & Coupe Express & 1938-42 President. Truck: M5 & 2R-2E 5, 6, 7 & 3E-6E 1-3, 5-7 & 7E-8E 5, 7. .... **\$35.00 ea.**
- 194826** Bearing. 1939-50 Champion. New production bearing. .... **\$169.50 ea.**
- 510728** Bearing. 1932-33 Rockne 30 & 31. 1934-37 Dictator. .... **\$36.00 ea.**
- 511664** Bearing. 1934 Commander 8. .... **\$40.00 ea.**
- 530451** Bearing. 1951-64 car, all models & 1963-64 Avanti with tapered axle. **\$40.55 ea.**
- 1562421** Bearing. 1965-66 car all models & 1964-70 Avanti with flanged axle. **\$41.50 ea.**

## REAR AXLE HOUSING COVERS & COVER GASKETS

- 194839** Cover. 1939-64 all models with 23 or 27 rear axle. .... **\$25.85 ea.**
- 511674** Gasket. 1936-50 Dictator, Commander & Coupe Express, 1934 Commander 8, 1938-42 President. Truck: M5, 2R5 & early 6. .... **\$8.50 ea.**
- 1560244** Cover. 1965-66 with 27 rear axle. .... **\$22.80 ea.**
- 1560245** Gasket. 1939-66 car, all models with #23 or #27 differential. .... **\$10.00 ea.**
- 1561783** Gasket. 1951-66 car, all models & 1963-70 Avanti with #44 differential. Truck: 2R-8E: 1, 2, 3, 5, 6, 7. .... **\$10.00 ea.**

## REAR AXLE SEALS

- 197216** Felt insert, only. For outer rear wheel seal. 1939-50 Champion. 1951-66 car all models & 1963-70 Avanti with tapered axle. .... **\$2.75 ea.**
- 197591** Felt insert, only. For outer rear wheel seal. 1941-64 1/2 ton pickups & 1947-50 Commanders. .... **\$4.25 ea.**
- 533161** Seal & gasket. 1939-50 Champion. 1951-66 car all models & 1963-70 Avanti with tapered axle. Includes #197436 gasket. .... **\$20.00 ea.**

## Special Differential Seal Kit

1951-64 Car all models & 1963-70 Avanti (With tapered axles)

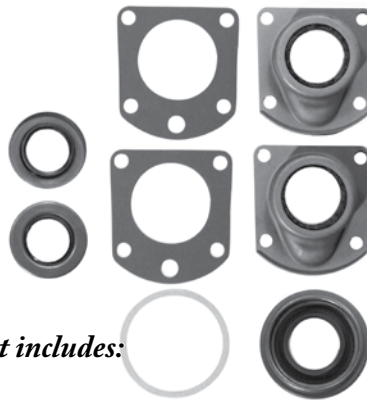
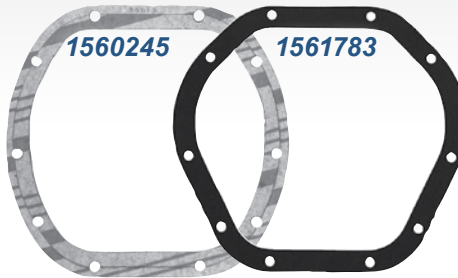

### Kit includes:

- 4 **197436**.....Gasket, outer seals
- 1 **199379X1 & 184161**. Pinion seal set
- 2 **533161**..... Outer axle seals
- 2 **530573**..... Inner axle seals
- 1 **1560245 ( #23 or #27) or 1561783 (#44)**..... Rear cover gasket

Total of all parts listed if purchased separately.....\$107.00

**801041R**  
SPECIAL PACKAGE PRICE .....**\$96.00/kit**

NOTE: SPECIFY DANA #23, #27 OR #44 DIFFERENTIAL WHEN ORDERING.

NUMBER IS CAST ON RIGHT LOWER REAR CORNER OF DIFFERENTIAL BELOW THE COVER.

Specify year & model when ordering.

No substitutions or deletions.



## REAR AXLE SHIMS

1939-50 Champion. 1951-66 car all models & 1963-70 Avanti with tapered axles.

- 194844** .005..... **\$4.25 ea.**
- 194845** .010..... **\$4.25 ea.**
- 194846** .030..... **\$4.25 ea.**

## REAR AXLE PINION SEALS

- 199379X1 & 184161** Seal & gasket set. 1947-66 car, all models & 1963-70 Avanti. 1939-46 Champion & 1938-42 Commander & President. 1935-37 Dictator. 1937-39 Coupe Express. Truck: M5 & 2R-8E 1, 2, 3, 5, 6, 7. .... **\$16.00 set**
- 630680** Truck: 1941-48 M15 & M16, 2R, 14, 15, 16, 28 with split type rear axle. .... **\$20.00 ea.**
- 640666** Truck: 1941-56 with 2-speed. .... **\$32.00 ea.**
- 677658** Truck: 1949-55 3/4-ton. .... **\$25.00 ea.**
- 678138** Truck: 1949-61 16-28 with banjo-type rear end. .... **\$25.00 ea.**
- 683328** Truck: 1954-56 13-14-15 & 1957-58 models 16 & 28 with banjo-type rear end. .... **\$28.00 ea.**
- 911600** Truck: 1957-64 model 40 with heavy duty rear axle. .... **\$25.00 ea.**
- 1685551** Truck: 1956-64, 3/4-ton. Spicer. .... **\$28.00 ea.**
- 1686005** Truck: 1957-61 with 2 speed rear axle. .... **\$20.00 ea.**
- 1688762** Truck: 1957-64 model 40 with standard rear axle. .... **\$28.00 ea.**
- 1689046** Truck: 1962-64 7E & 8E models 40 & 45 with 2 speed rear axle. .... **\$38.00 ea.**
- 1691942** Truck: 1962-64 13 & 15 with Timken axles. .... **\$20.00 ea.**

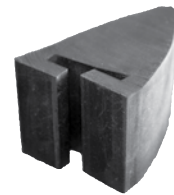

## REAR AXLE BUMPERS

- 433812** 1958-64 Hawk & 1961-64 Lark with 4-speed, 1962-66 Lark 4-door. .... **\$12.00 ea.**
- 530333** 1951-57 Champion, all. 1958 Champion except C & K, 1951-54 Commander, all & 1956-57 Station wagon. Trucks: Late 2R5-8E 5, 6, 7, 10, 11, 12. .... **\$10.00 ea.**
- 1547536** 1953-66 most models and 1963-85 Avanti. .... **\$8.00 ea.**

## REAR AXLE HARDWARE

- 63X33** Nut. 1934-50 Commander, President, Dictator. .... **\$8.00 ea.**
- 194841** Shaft key. 1947-50 Champion & 1951-66 car all models & 1963-64 Avanti. **\$5.00 ea.**
- 510516** Nut. 1951-64 car. 1934-37 Dictator. 1934 Commander & 1951-64 car all models & 1963-64 Avanti. .... **\$10.65 ea.**
- 537906** Nut. 1939-50 Champion... **\$8.00 ea.**





## REAR AXLE SEALS INNER

- 197436** Gasket, differential to brake backing plate. 1939-50 Champion. 1951-66 car all models & 1963-70 Avanti with tapered axle. .... **\$1.50 ea.**
- 516329** 1938-50 Commander. 1938-42 President. Truck: M5 & 2R, 3R & E 5, 6, 7. .... **\$18.50 ea.**
- 516330** 1939-50 Champion. .... **\$20.00 ea.**
- 530573** 1951-66 car, all models & 1963-70 Avanti with tapered axle. .... **\$18.00 ea.**
- 665620** 1941-48 M16-M17 Truck & all big trucks thru 1964. .... **\$15.00 ea.**
- 677318** Truck: 2R-2E 10, 11, 12 **\$21.50 ea.**
- 1685410** Truck: 2E: 5, 6, 7 & 3E-6E: 1, 2, 3, 5, 6, 7 & 7E, 8E: 5, 7. .... **\$25.50 ea.**
- 1685869** Truck: late 2E, 3E-6E: 10, 11, 12 & 7E-8E: 10, 12. .... **\$20.50 ea.**

## FRONT WHEEL GREASE SEALS

- 191703** 1938-49 Commander & President. Truck: M5 & 2R 5 (early). .... **\$11.50 ea.**
- 194288** 1939- early 48 Champion. .... **\$5.90 ea.**



- 524096** 1950 Commander. Truck: (late) 2R-6E 1, 2, 3, 5, 6, 7, & 7E-8E 5, 7. ... **\$16.00 ea.**
- 665604** Truck: M16, 17 & 2R-6E; 16, 17, 28, 38 & 7E-8E 25, 28, 35. .... **\$18.50 ea.**
- 677314** Late 1948-55 Champion & 1951-55 Commander & President. Truck: 2R-2E: 10-12. .... **\$14.00 ea.**
- 1539027** 1956-66 car, all models & 1963-83 Avanti. .... **\$9.00 ea.**

## WHEEL STUDS & NUTS

- 196308** Lug nut, right hand thread. 1939-50 Champion. 1951-66 car, all models. Truck: 2E-6E 10, 12 & 3E, 4E 4WD 2, 3, 6, 7 & 7E 10, 12. .... **\$1.25 ea.**



- 196309** Lug nut, left hand thread. 1939-50 Champion & 1951-58 car, all models. .... **\$1.50 ea.**



- 196930** Wheel stud, right hand thread. 1939-50 Champion & 1951-63 car, all models except those with disc brakes. Exact duplicate of original with correct shoulder. .... **\$2.50 ea.**



- 196931** Wheel stud, left hand thread. 1939-50 Champion & 1951-58, cars, all models. .... **\$3.50 ea.**

- NEW Listing - 511300** Nut. Fits 523702 stud. .... **\$3.75 ea.**

- NEW Listing - 511301** Nut. Fits 523703 stud. .... **\$3.75 ea.**

- 523702** Wheel stud, right hand thread. All 1938-50 cars except Champion. Truck: all 1/2-ton 1941-64. .... **\$3.75 ea.**

- 523703** Wheel stud, left hand thread. All 1938-50 cars except Champion. Truck: all 1/2-ton 1941-58. .... **\$2.50 ea.**

- 1557509** Wheel stud front, all disc brake cars. 1963-66 & Avanti 1963-83. .... **\$3.50 ea.**



- 1561095** Wheel stud. 1963-66 Lark & Hawk with front disc & 1963-64 Avanti rear. .. **\$4.50 ea.**

## Front Wheel Bearing & Grease Seal Kit



- |     |                     |         |     |                     |         |
|-----|---------------------|---------|-----|---------------------|---------|
| • 2 | <b>194211</b> ..... | Cup     | • 2 | <b>194215</b> ..... | Bearing |
| • 2 | <b>194214</b> ..... | Cup     | • 2 | <b>194288</b> ..... | Seal    |
| • 2 | <b>194212</b> ..... | Bearing |     |                     |         |

- 801831** 1939-40 Champion models 10-piece kit includes inner and outer bearings, cups and grease seals for both sides of vehicle. .... **\$250.00/kit**

## FRONT WHEEL BEARINGS & RELATED PARTS

- 130980** Inner cup. 1938-49 Commander. Truck: M5 & early 2R 5. .... **\$21.50 ea.**

- 130983** Outer cup. 1941-early 48 Champion & 1934-49 Commander. Truck: M5, M15 & early 2R 5. .... **\$17.50 ea.**

- 130984** Outer bearing. 1941-early 1948 Champion & 1934-49 Commander. Truck: M5, M15 & early 2R 5. .... **\$41.00 ea.**



- 130986** Lock washer, front wheel bearing. 1941-46 Champion & 1947-55 car, all models. .... **\$4.50 ea.**

- 165052** Outer bearing. 1934-37 President & 1934 Commander. Truck: M15, 15A & 2R-2E 13, 14, 15 & 3E-4E 10-14 & 7E - 8E 10, 12, 13, 15. .... **\$49.50 ea.**

- 167480** Inner bearing. 1938-49 Commander. Truck: M5 & early 2R 5. .... **\$33.50 ea.**



- 188102** Dust cap. 1930-31 Rockne, 1939-46 Champions. All cars 1934-55 except Presidents prior to 1938. Trucks: All 1/2 ton 1941-64 & some 7E & 8E 3/4 ton. .... **\$15.00 ea.**

- 194211** Inner cup. 1939-early 48 Champion. .... **\$21.00 ea.**

- 194212** Inner bearing. 1939 - early 1948 Champion. .... **\$38.25 ea.**

- 194214** Outer cup. 1939-40 Champion. .... **\$20.50 ea.**

- 194215** Outer bearing. 1939-40 Champion. .... **\$50.75 ea.**

- NEW Listing - 194290** Dust cap. 1939-40 Champion. .... **\$15.00 ea.**

- 473256** Outer bearing. 1956-66 car all models & 1963-83 Avanti. Truck: 4E-6E 1, 2, 3, 5, 6, 7 & 7E-8E 5, 7. .... **\$12.50 ea.**

- 473257** Outer cup. 1956-66 car all models & 1963-83 Avanti. Truck: 4E-6E 1, 2, 3, 5, 6, 7 & 7E-8E 5, 7. .... **\$6.50 ea.**

- 473258** Inner bearing. 1956-66 car all models & 1963-83 Avanti. Truck: 4E-6E 1, 2, 3, 5, 6, 7 & 7E-8E 5, 7. .... **\$14.00 ea.**

- 473259** Inner cup. 1956-66 car all models & 1963-83 Avanti. Truck: 4E-6E 1, 2, 3, 5, 6, 7 & 7E-8E 5, 7. .... **\$8.25 ea.**

- 510278** Inner cup. 1934-37 Dictator & 1937 Coupe Express. Truck: M15-17 & 2R-6E 16, 17, 28, 38 & 7E-8E 25, 28, 35. .... **\$18.00 ea.**

- 510279** Inner bearing. 1934-37 Dictator & 1937 Coupe Express. Truck: M15. .... **\$29.75 ea.**

- 661346** Outer bearing. Truck: M15 & 2R 14, 15. .... **\$56.90 ea.**

- 677308** Inner bearing. Late 1948-55 Champion & 1950-55 Commander. Truck: 2R-2E 5, 6, 7, 10, 11, 12 & 3E 1, 5, 6, 7. (Late 2R5). .... **\$23.50 ea.**

- 677309** Inner cup. Late 1948-55 Champion & 1950-55 Commander. Truck: 2R-2E 5, 6, 7, 10, 11, 12 & 3E 1, 5, 6, 7. (Late 2R5). .. **\$11.00 ea.**

- 677310** Outer cup. 1948-55 Champion & 1950-55 Commander. Truck: 2R-2E 5, 6, 7, 10, 11, 12 & 3E 1, 5, 6, 7. (Late 2R5). .. **\$12.50 ea.**

- 677311** Outer bearing. 1948-55 Champion & 1950-55 Commander. Truck: 2R-2E 5, 6, 7, 10, 11, 12 & 3E 1, 5, 6, 7. (Late 2R5). . **\$27.00 ea.**

- 1539025** Dust cap. 1956-66 car all models & 1963-83 Avanti. .... **\$13.50 ea.**

- 1543223** Spindle nut. 1934-66 car, most models. 1963-83 Avanti. Truck: M5 & 2R-8E most models. .... **\$6.00 ea.**



## SHOCK ABSORBER RELATED PARTS

**170200** Front shock bushing. 1931-32 Rockne, 1930-31 Studebaker 6, 1934 Dictator "A", 1941-48 M5 & early 2R5 & 2R10 pickups with lever action shocks. Takes 4. ... **\$2.50 ea.**

**170200** Rear shock bushing. Late 1932 Rockne 65, 1933 Rockne, 1930-31 Studebaker 6, 1934 Dictator "A", 1941-48 M5 & early 2R5 & 2R10 pickup with lever action shocks. Takes 4. .... **\$2.50 ea.**

**193878** Front shock grommet. 1947-49 Champion & 1947-50 Commander. Takes 4. . **\$3.00 ea.**



**195284** Rear shock bushing. 1939-49 Champion & 1947-50 Commander. Takes 4. **\$3.25 ea.**



**198685** Rear shock bushing. 1941-42 Commander & President. Takes 4. .... **\$4.50 ea.**

**510568** Metal retainer for front shock grommet. 1950 Champion and all 1951-66 car except Avanti & 1961-66 car with original heavy duty adjustable Gabriel shocks. Takes 8 thru early 1957 & 4 thereafter. .... **\$1.00 ea.**



**522673** Front shock grommet. 1950 Champion & all 1951-66 car except Avanti & 1961-66 car with original heavy duty adjustable Gabriel shocks. Takes 8 thru early 1957 & 4 thereafter. .... **\$3.00 ea.**

**522777** Metal seat for front shock grommet. 1950 Champion and all 1951-66 cars except Avanti & 1961-66 car with original equipment heavy duty Adjustable Gabriel shocks. 1950-early 1957 takes 4, thereafter takes 2. .... **\$2.00 ea.**

**523300** Spacer for front shock grommet on all 1947-49 cars & 1950 Commander. Also used on rear of 1947-49 Champion. .... **\$2.00 ea.**

**523301** Spacer for rear shock grommet on 1947-50 Commander. .... **\$3.95 ea.**

**524831** Rear shock upper mounting stud for 1950 Champion & all 1951-early 1957 car. .... **\$7.50 ea.**

**524832** Rear shock upper spacer on 1950 Champion & all 1951-early 1957 car. .... **\$4.00 ea.**

**524833** Spacer, lower rear shock. 1950 Champion..... **\$4.00 ea.**



**524834** Spacer, upper rear shock. 1950 Champion. .... **\$5.50 ea.**

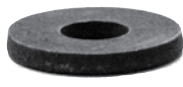

**531075** Special front shock mounting bolt for late 1957 & all 1958-66 car & Avanti thru 1985. .... **\$3.50 ea.**

**1546133** Front shock bushing. 1937-38 car and early 1939 Commander. Rear, 1950 Champion & all 1951- early 1957 car with original equipment shocks. Takes 8. .... **\$3.50 ea.**



## Gabriel Classic Gas Shock Absorbers\*

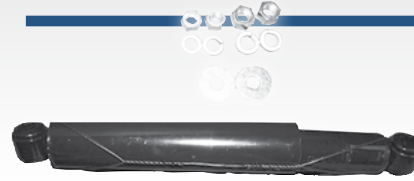

### FRONT SHOCK ABSORBERS

Gabriel was an original Studebaker & Avanti shock absorber for many years. These high quality shocks enable your Studebaker & Avanti to perform like new.

**\*800693** 1950 Champion & 1951-early 57 all models ..... **\$34.95 ea.**

**\*800694** Late 1957-66 all models & 1963-85 Avanti ..... **\$34.95 ea.**

### REAR SHOCK ABSORBERS

**\*\*800697** 1950 Champion & 1951-56 all models and early 1957. .... **\$34.95 ea.**

**\*800698** 1963-66 Lark & Hawk & late 1963-85 Avanti ..... **\$34.95 ea.**

**800930** Late 1957-62 all models and early 1963 Avanti. .... **\$34.95 ea.**



NOTE: MOUNTING HARDWARE FURNISHED W/ THE SHOCKS MAY NOT DUPLICATE THE ORIGINAL FACTORY PIECES, AND MAY REQUIRE MODIFICATION OR REPLACEMENT TO ENSURE PROPER FIT. \*\* INCLUDES BUSHINGS, NUTS & METAL RETAINERS.\* INCLUDES MOUNTING STUDS, NUTS & WASHERS.

### TRUCK SHOCK ABSORBERS

**800942** Truck: 1950-60, front & rear ..... **\$39.95 ea.**

**NEW Listing - 1697581** 1961-64 Truck. Hydraulic. NOS. .... **\$60.00 ea.**

## Lever Type Shocks

**518009** Right rear. Early 1947 Commander, except Convertible. .... **\$55.00 ea.**

**518010** Left rear. Early 1947 Commander except Convertible. .... **\$55.00 ea.**

**523497** Right or left rear. Late 1947 & all 1948 Commander except 1947 & early 1948 Convertibles. .... **\$80.00 ea.**

**523538** Right rear. 1947 & early 1948 Commander Convertible. .... **\$120.00 ea.**

**523539** Left rear. 1947 & early 1948 Commander Convertible. .... **\$120.00 ea.**

**526092** Right front. 1950 Commander. .... **\$40.00 ea.**

**526093** Left front. 1950 Commander. .... **\$40.00 ea.**

**526148** Right rear. 1950 Commander. .... **\$80.00 ea.**

**526149** Left rear. 1950 Commander. .... **\$80.00 ea.**

**676683** Left front. Truck: Early 2R 5,10. .... **\$120.00 ea.**

## UNIVERSAL JOINTS



**516059** 1936-66 all models & 1963-85 Avanti. Truck: 1949-60 various models. Spicer. .... **\$20.00 ea.**

**679937** Truck: M5 with 4 speed & early M15's. .... **\$45.00 ea.**

**1559481** 1963-64 all models with Mechanics front. .... **\$31.00 ea.**

**1559482** 1963-64 all models with Mechanics rear. .... **\$36.60 ea.**

**1687069** Truck: 1957-64 with Cleveland. .... **\$25.00 ea.**

NOTE: 1964 LARKS & HAWKS USE BOTH SPICER & MECHANICS U-JOINTS. BE SURE TO CHECK YOURS AS TO THE TYPE BEFORE ORDERING.

The following truck U - Joints are available, check your truck parts book for year & model.

**670774** ..... **\$46.00 ea.**

**674156** ..... **\$46.00 ea.**

**682027** ..... **\$27.00 ea.**

**1687083** ..... **\$78.00 ea.**

**1687253** ..... **\$46.00 ea.**

**1687692** ..... **\$25.00 ea.**

**1690409** ..... **\$25.00 ea.**

**1691761** ..... **\$27.00 ea.**

**1691762** ..... **\$67.00 ea.**

From Chicago, Illinois, Richard Salach's 1940 Champion 2 door Sedan with a peek at the front end of his 1931 Packard 833 Roadster.



**677156** Right rear. Truck: 2R-3 E 13, 14, 15, 16, 28, 38. .... **\$140.00 ea.**

**677157** Left rear. Truck: 2R-3 E 13, 14, 15, 16, 28, 38. .... **\$140.00 ea.**

**678630** Right front. Truck: 2R-2E 6, 7, 11,12, 3-E, 5, 6, 7, 10, 11, 12. .... **\$95.00 ea.**

**678631** Left front. Truck: 2R-2E late 2R 6, 7, 11, 12, 3-E, 5, 6, 7, 10, 11, 12. .... **\$95.00 ea.**

**678632** Right rear. Truck: 2R-2E late 2R 6, 7, 11, 12, 3-E, 5, 6, 7, 10, 11, 12. .... **\$95.00 ea.**

**678036** Right front. Truck: 2R-2E 13,14,15, 3E 13,14. .... **\$120.00 ea.**

**678037** Left front. Truck: 2R-2E 13, 14, 15, 3E 13, 14. .... **\$120.00 ea.**

NOTE: LEVER SHOCKS ARE NOS EVEN THOUGH THE SHOCKS ARE "NEW", THE SEALS ARE OLD & CARRY NO WARRANTY AGAINST LEAKAGE.

\* WE HAVE OTHER LEVER TYPE SHOCKS TOO. PLEASE INQUIRE.



## DRIVE SHAFT CENTER SUPPORT BEARING

**517450** Bearing. All 1947-49 Cars & early Production 1950 Canadian Champion.

.....\$47.50 ea.

**664443** Bearing. All 1950-57 Cars (US made) & late 1950 Canadian Champions. Truck: M15, 15A, 16, 17 & 2R-8E all models. Pictured, above. ....\$46.50 ea.



## DRIVE SHAFT CENTER SUPPORT CUSHION

**519175** 1947-1957 car, all models. Takes 2. ....\$5.50 ea.

**664444** Truck: 1941-48 M15, 16 & 17 trucks with original equipment center support.

.....\$10.00 ea.

**679292 & 679293** Truck: 1941-64 with two piece drive shaft. ....\$6.00 set/4



## Special Drive Shaft Rebuild Kit

For 1947-57 car all models

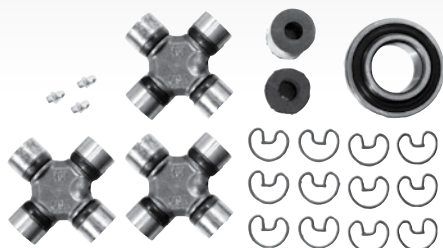

### Kit includes:

- 3 516059 U - Joints. Spicer
- 2 519175 Center support cushion
- 1 517450 or 664443 Center support bearing

### 1947-1949 CARS

US made & early 1950 Canadian Champion

Total of all parts listed if purchased separately.....\$118.50

**801042R**

SPECIAL PACKAGE PRICE .....\$105.00/kit

U.S. MADE **1950-57 CARS**  
& late 1950 Canadian Champion

Total of all parts listed if purchased separately.....\$117.50

**801043R**

SPECIAL PACKAGE PRICE .....\$110.00/kit

*NOTE: Specify year & model when ordering. No substitutions or deletions.*

## Differential & Pinion Bearings

**127013** Cup, rear pinion bearing. Car: 1929-30 Commander 8, GT & FD. 1929-30 Dictator delivery, GL with tapered shaft & key before serial # 3,760,797. ....\$28.00 ea.

**127013** Cup, pinion shaft front bearing. 1929-30 Dictator delivery with spline pinion shaft after serial #3,760,797. Also used on GE 1928-29 Dictator & 1932-33 Studebaker 55 & 56. 8-cyl applications are FC & FD 1929-30 Dictator with spline pinion shaft, 1929-30 President, 1932 Dictator 8, 1930-33 Commander 8, 1931-33 President & 1935 Commander & President 8.

.....\$28.00 ea.

**156682** Bearing rear pinion for cars. GE 1928-29 Dictator with single unit or split carrier with pinion 1 5/8" diameter at drive end. 1934 President with axles dated before 4/11/34.

.....\$42.00 ea.

**156684** Cup, rear pinion bearing. Car: 1929-30 Dictator delivery after serial# 3,760,797 with tapered shaft. GE 1928-29 Dictator, 1932-33 Rockne 55 & 56, 1929-30 Dictator & Commander 8, 1932 Dictator 8, 1930-33 Commander 8, 1933 President 8 and 1935 Commander & President 8. ....\$23.00 ea.

**165133** Bearing, rear pinion. Car: GJ 1929 Commander & GL 1929-30 Dictator with tapered pinion shaft & key before serial #3,760,797. Also FD 1929-30 Commander 8 with tapered pinion shaft before serial #8,019,661. ....\$47.00 ea.

**177644** Bearing rear pinion. Car: 1933 Studebaker model 56, 1933 & 1935 Commander & President 8. ....\$72.00 ea.

**183903** Bearing, rear pinion. Car: 1934 President with axle dated after 4/11/34 and all 1936-37 President. ....\$42.00 ea.

**183904** Cup, rear pinion bearing. Car: 1934 President with axles dated after 4/11/34 & all 1936-37 Presidents. ....\$23.00 ea.

**190032** Cup, pinion front. 1965-66 with #44 differential. 1947-58 car, all models & 1963-70 Avanti. Truck: M5 & 2R-8E 1, 2, 3, 5, 6, 7, 1936 Dictator & all other 1936-46 cars.

.....\$17.50 ea.

**190033** Bearing, pinion front. 1965-66 with #44 differential. 1959-64 car, all models with #23 or #44 differential. 1947-58 car, all models & 1963-70 Avanti. Truck: M5 & 2R-8E 1, 2, 3, 5, 6, 7. Late 1936 Dictator & all 1937-46 Commander, Dictator, Champion & 1938-42 President. ....\$40.50 ea.

**190035** Cup, pinion rear. 1947-58 car, all models. 1959-64 car all models with #23 or #44 differential. 1965-66 with #44 differential & 1963-70 Avanti. Truck: M5 & 2R-8E 1, 2, 3, 5, 6, 7. 1936-46 Dictator & Commander, Coupe Express, Champion & 1938-42 President.

.....\$18.65 ea.

**190036** Bearing, rear pinion. 1947-58 car, all models & 1963-70 Avanti. 1959-64 car all models with #23 or #44 differential. 1965-66 with #44 differential & 1963-70 Avanti. Truck: M5 & 2R-8E 1, 2, 3, 5, 6, 7. Late 1934 Dictator & all 1935-45 Dictator, Commander, Coupe Express & 1938-42 President. ....\$51.00 ea.

**190047** Cup, differential bearing. 1947-54 Commander. 1955-59 V-8. 1958 Champion. 1959-64 car all models & 1963-70 Avanti. Truck: M5 & 2R-8E 1, 2, 3, 5, 6, 7. Late 1936 Dictator & all 1937-42 Dictator, Commander, Coupe Express & 1938-42 President. Takes 2. ....\$23.50 ea.

**190048** Bearing differential. 1947-54 Commander. 1955 car, all models & 1963-70 Avanti. Truck: M5 & 2R-8E 1, 2, 3, 5, 6, 7. Late 1936 Dictator & all 1937-42 Dictator, Commander, Coupe Express & 1938-42 President. Takes 2. ....\$51.00 ea.

**192238** Cup, truck differential & rear axle bearing. 1941-64 1/2 ton, all. ....\$18.50 ea.

**192239** Bearing, truck differential & rear axle. 1941-64 1/2 ton, all. ....\$35.00 ea.

**196286** Cup, differential bearing. 1939-58 Champion. 1959-60 with #23 differential.

.....\$51.00 ea.

**196287** Bearing, differential. 1939-58 Champion & 1959-60 with #23 differential.

.....\$49.75 ea.

**510693** Cup, rear pinion bearing. Car:

1929-30 Dictator 6, 1930-31 Studebaker 6, 1930-32 Rockne, 1935-36 Dictator and 1934-37 Commander & President 8.

Also -cup, pinion shaft front bearing. Car: 1932-33 Rockne 30 & 31, 1934 - early 36 Dictator, 1934 Commander & President 8 and 1936-37 President. ....\$24.00 ea.

**510694** Bearing, rear pinion for cars. 1932-33 Rockne (30&31); 1934-35 Dictator. Bearing front pinion. 1934-36 Canadian-made Dictator.

.....\$50.00 ea.

**1549625** Cup, pinion shaft front bearing. 1960-66 with #27 differential. ....\$11.00 ea.

**1549626** Bearing, pinion front. 1960-66 with #27 differential. ....\$48.00 ea.

**1549627** Cup, rear pinion. 1960-66 with #27 differential rear axle. ....\$15.50 ea.

**1549628** Bearing, rear pinion. 1960-66 with #27 rear differential. ....\$38.50 ea.

**1549645** Cup, differential bearing. 1960-66 with #27 differential. ....\$36.90 ea.

**1690219** Bearing differential. 1960-66 with #27 differential. ....\$25.25 ea.

**6484102** Bearing, differential. 1965-66 #44 flanged differential. ....\$33.75 ea.

NOTE: THE FOLLOWING DIFFERENTIAL & AXLE BEARINGS FOR THE LARGER TRUCKS ARE AVAILABLE. PLEASE CONSULT YOUR FACTORY PARTS BOOK FOR EXACT YEAR & MODEL APPLICATION.

**181794** Bearing .....\$33.00 ea.

**630703** Bearing.....\$50.00 ea.

**630728** Cup.....\$32.00 ea.

**631956** Cup.....\$22.00 ea.

**631959** Bearing.....\$29.50 ea.

**634304** Bearing.....\$48.00 ea.

**636343** Cup.....\$32.00 ea.

**636346** Bearing.....\$50.00 ea.

**639182** Cup.....\$56.00 ea.

**640080** Bearing.....\$38.00 ea.

**662777** Cup.....\$30.00 ea.

**664736** Cup.....\$24.00 ea.

**674450** Cup.....\$24.00 ea.

**677296** Bearing.....\$38.00 ea.

**677297** Cup.....\$19.50 ea.

**1685901** Bearing.....\$31.00 ea.

**1685902** Bearing .....\$42.00 ea.

**1685908** Cup .....\$30.00 ea.

**1687471** Bearing .....\$65.00 ea.

**1690124** Bearing.....\$65.00 ea.

## NOS - LEAF SPRINGS for Trucks

TRUCK REAR SPRINGS WERE AVAILABLE IN EITHER SINGLE OR TWO STAGE CONFIGURATION, AND WITH OR WITHOUT AUXILIARY SPRINGS. WE HAVE INCLUDED THE FACTORY PARTS BOOK ILLUSTRATION NUMBERS (IN PARENTHESIS) ON ALL TRUCK SPRINGS LISTED FOR EASE OF IDENTIFICATION. REFER TO FACTORY BOOKS.

**673887X** Rear main spring. 2R 16 heavy duty. 2R17 standard duty prior to serial # R16A-17,194 and R17A-9,943. (1518-1) .....**\$795.00 pr.**

**676849X** Rear main spring. Standard duty. 2R models 5 & 6. All 2R5's and 2R6's prior to serial # R6-11,867. (1518-1) .....**\$795.00 pr.**

**677056X** Front spring. Heavy duty on 2R through E models 13, 14, 15. Also standard duty on 2E models 13 & 14. (1510-1) ...**\$750.00 pr.**

**677057X** Front spring. Standard duty 2R through E models 16 & 28. ....**\$750.00 pr.**

**677058X** Front spring. Standard duty. 2R through E models 17 & 38. Standard duty on 2E models 38 models with 131" wheelbase. Also heavy duty on 2R through E 16 & 28 models. (1510-1).....**\$775.00 pr.**

**677274X** Front spring. Standard duty. 2R through E models 13, 14, 15. Also standard duty on 2E models 13 & 14. (1510-1) .....**\$725.00 pr.**

**677526X** Front spring. Standard duty type-A, 2R5 & 2R10 prior to serial # R5-13,771 & R10-5,382. (1510-1) .....**\$595.00 pr.**

**677528X** Front spring. Heavy duty type-A, 2R5 & 2R10 prior to serial # R5-14,641 & R10-5,961. (1510-1) .....**\$650.00 pr.**

**678734X** Rear main spring. Late 2R 10 after serial # R-10, 19265 and all 2R11 & 12, 15 through 2E 10, 11 & 12. (1518-1). **\$745.00 pr.**

**678842X** Rear main spring. Late 2R15 and all 2R 13 & 14 through 2E 13, 14, & 15. 2R15's after serial # R15-7,072. (1518-1) **\$765.00 pr.**

**678846X** Rear main spring. Late 2R15 after serial # R15-8,768 and all 2R through 2E 13, 14, & 15 with 131" wheelbase. (1518-1) .....**\$765.00 pr.**

**679131X** Front spring. Heavy duty. 2E models 28 & 38. Also heavy duty on 2E 38 with 131" wheelbase and standard duty on other 2E38's. (1510-1) .....**\$795.00 pr.**

**679852X** Rear spring. Light duty. 2R5 & 2R6. 2R 5 after serial # R5-46,122. 2R6 from serial # R6-202 to R6-11,867. (1518-2) ...**\$595.00 pr.**

**679859X** Rear spring. 2-stage light duty late 2R10 after serial # R-10 21,512 & all 2R 11 & 2R 12 through E-10, 11, & 12. (1518-2) .....**\$695.00 pr.**

**681192X** Rear main spring. Heavy duty. 2R16 after serial # R16-39,498. Also 2R16 & 17. Standard duty after serial # R16A-38,770 and R17A-31,034. 3R through E models 16, 17, 28, 38. Heavy duty on models 16 & 28. Lastly, heavy duty on 2E 28. (1518-1).....**\$845.00 pr.**

**681195X** Rear main spring. 2R17 and extra heavy duty on 2R16. 3R16 through 38, heavy duty on 2R16 & 28. Heavy duty on E17 & 38. And standard duty on 2E 38. (1518-1) **.\$845.00 pr.**

**681903X** Rear main spring. Standard duty. 3R through 2E models 5, 6, 7. (1518-1) .....**\$595.00 pr.**

**681904X** Rear main spring. 2-stage, light duty. 2R models after serial # R6-11,867. Also 3R and 2 E models 5, 6, 7. (1518-2) .....**\$695.00 pr.**

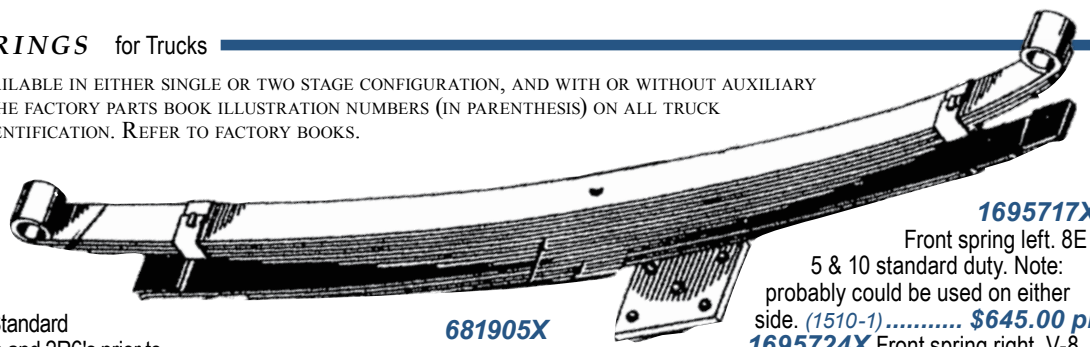

### 681905X

Rear spring. 2-stage, heavy duty. 2R6 models after serial # R6-11,867. Also 3R and E models 5, 6, 7. (1518-2) .....**\$695.00 pr.**

**684053X** Rear main spring. Standard duty. E-series models 16 & 28 and 2E model 28. (1518-1) .....**\$795.00 pr.**

**684056X** Rear main spring. Heavy duty. E16, 17, 28 & 38. (1518-1) .....**\$845.00 pr.**

**684332X** Rear main spring. 2-stage, heavy duty. E models 16, 17, 28, 38. Also 2E 38 model. (1518-2).....**\$845.00 pr.**

**1685100X** Rear spring. 2-stage heavy duty. 2E models 5, 6, 7. (1518-2) .....**\$745.00 pr.**

**1685104X** Rear spring. 2-stage heavy duty 2E models 10,11,12. (1518-2) ....**\$845.00 pr.**

**1685189X** Rear spring. 2-stage, light duty 2E models 13 & 14 truck. (1518-2) ..**\$850.00 pr.**

**1687598X** Front spring. Heavy duty, on 3E 16 & 28 models and 3E 17 & 38 models with 131" wheelbase. Standard duty on all 3E 17 & 38 models except those with 131" wheelbase and also standard duty on 3E through 8E 35, 40 & 45 models. Lastly, heavy duty on 7E & 8E 25 & 38 models. (1510-1) .....**\$795.00 pr.**

**1687673X** Front spring. Standard duty. 3E through 8E 13 & 14 models. (1518-1) (1510-1) .....**\$725.00 pr.**

**1687678X** Rear spring. 2-stage standard duty 3E through 8E models 13, 14, 16, 28 and 25. (1518-2).....**\$795.00 pr.**

**1687684X** Rear spring. 2-stage standard duty. 3E thru 8E, 25, 28, 35, 40, 45, 16, 17, 38. Heavy duty on 25 & 28. (1518-2) .....**\$845.00 pr.**

**1687701X** Rear spring. Auxiliary standard duty. 2E through 8E models 16,25,28. (1518-3) .....**\$895.00 pr.**

**1687705X** Rear main spring. Auxiliary, extra heavy duty. 2E through 8E models 16,25, 28,35, 40, 45. (1518-3) .....**\$945.00 pr.**

**1691609X** Front spring. Heavy duty. 4E through 8E models 40 & 45. (1518-1) .....**\$795.00 pr.**

**1691610X** Front spring. Extra heavy duty. 4E through 8E models 40 & 45. (1510-1) .....**\$895.00 pr.**

**1693302X** Rear spring, 2-stage standard duty. 6E (1961) through 8E (1964) models 5 & 7. (1518-2) .....**\$595.00 pr.**

**1693361X** Rear spring. 2-stage heavy duty. 6E (1961) through 8E (1964) models 5 & 7. Also standard duty on 6E through 8E models 10 & 12 3/4-ton truck. (1518-2)..... **\$695.00 pr.**

**1693853X** Front spring. Heavy duty. 7E 5 & 10 models. Also standard duty on 7E models 7 & 12. (1510-1)..... **\$695.00 pr.**

**1695716X** Front spring, right. 8E 5 & 10 standard duty. Note: probably could be used on either side. (1510-1) ..... **\$645.00 pr.**

### 1695717X

Front spring left. 8E 5 & 10 standard duty. Note: probably could be used on either side. (1510-1)..... **\$645.00 pr.**

**1695724X** Front spring right. V-8

1/2-ton truck 8E 7. (1510-1) ..**\$550.00 pr.**  
**1695725X** Front spring left. V-8 1/2-ton truck 8E 7. (1510-1).....**\$550.00 pr.**

Note: 1695724X and 1695725X should be interchangeable.

**1696382X** Front spring right. Heavy duty. 8E 7 & 12 truck.(1510-1) ..... **\$695.00 pr.**

**1696383X** Front spring left. Heavy duty. 8E 7 & 12 truck. (1510-1)..... **\$695.00 pr.**

Note: 1696382X and 1696383X should be interchangeable.

**1697206X** Rear spring. Postal Zip Van 8E 5-FC. (1518-2).....**\$595.00 pr.**

**1697210X** Front spring. Postal Zip Van 8E 5-FC. (1510-1).....**\$550.00 pr.**

## NOS - REAR LEAF SPRINGS for cars

**1540059X** 1956 All with A/C except 56 GH. ....**\$595.00 pr.**

**1541917X** 1957 Champion 6-cyl. 2-door & 4-door Sedan. ....**\$550.00 pr.**

**1544352X** 1957 Champion Scotsman 2-door & 4-door Sedan. ....**\$550.00 pr.**

**1545112X** 1958 Champion All body styles except Station Wagon. ....**\$550.00 pr.**

**1545113X** Standard duty. 1958 V-8 Sedan & J-Body Hardtops. ....**\$550.00 pr.**

**1545115X** 1958 4-door Champion Taxi. ....**\$550.00 pr.**

**1545116X** 1958 Champion 2-door Scotsman Wagon. ....**\$550.00 pr.**

**1547534X** Heavy duty. 1959-61 Station Wagon. ....**\$595.00 pr.**

**1547535X** Standard duty. 1959-61 Station Wagon. ....**\$550.00 pr.**

**1548320X** 1955-61 6-cyl. Hawk. ....**\$550.00 pr.**

**1552181X** 1961 Cruiser V-8. **\$550.00 pr.**

**1554563X** Standard duty. 1962 Lark all except Station Wagon. Probably all 1963-66 also. ....**\$550.00 pr.**

**1555712X** 1962 6-cyl. & V-8 Lark Taxi. ....**\$550.00 pr.**

**1556534X** 1962-64 Taxi. ....**\$550.00 pr.**

**1559758X** Standard duty. 1963-66 Lark all models except Station Wagon. ..**\$550.00 pr.**

**1560439X** Heavy duty. 1963-66 Station Wagon. ....**\$595.00 pr.**

### Note: NOS Leaf Springs

AVAILABILITY IS LIMITED TO STOCK ON HAND WHICH IN SOME INSTANCES IS EXTREMELY LIMITED. IF DEMAND WARRANTS, WE MAY CONSIDER REPRODUCTION OF CERTAIN UNITS.



**NEW - PRODUCTION**  
**REAR LEAF SPRINGS** for cars

- 536410** Standard. 1953-57 all models. ....**\$595.00 pr.**  
**536513** Heavy duty. 1953-57 all models. ....**\$610.00 pr.**  
**1545112** Standard. 1958 all Sedans except President. ....**\$595.00 pr.**  
**1545113** Standard. 1958 President. ....**\$595.00 pr.**  
**1545114** Standard. 1958 Station Wagon & 1959-61 Hawk. ....**\$595.00 pr.**  
**1545116** Heavy duty. 1958 all Sedans. ....**\$610.00 pr.**  
**1545117** Heavy duty. 1958-61 Station Wagon & Hawk. ....**\$610.00 pr.**  
**1547532** Heavy duty. 1959-61 Lark except Station Wagon. ....**\$610.00 pr.**  
**1547533** Standard. 1959-61 Lark except Station Wagon. ....**\$595.00 pr.**  
**1547534** Heavy duty. 1959-61 Lark Station Wagon. ....**\$610.00 pr.**  
**1547535** Standard. 1959-61 Lark Station Wagon. ....**\$595.00 pr.**  
**1554563** Standard. 1962-64 Lark except Station Wagon. ....**\$595.00 pr.**  
**1554565** Heavy duty. 1962-64 Lark except Station Wagon. ....**\$610.00 pr.**  
**1557249** Standard. 1963-85 Avanti. ....**\$595.00 pr.**  
**1557378** Heavy duty. 1963-85 Avanti. ....**\$610.00 pr.**  
**1557636** Heavy duty. 1962-64 Hawk. ....**\$610.00 pr.**  
**1557637** Standard. 1962-64 Hawk. ....**\$595.00 pr.**  
**1559758** Standard. 1965-66 Lark except Station Wagon. ....**\$595.00 pr.**  
**1559760** Heavy duty. 1962-64 Lark Station Wagon. ....**\$610.00 pr.**  
**1559760** Heavy duty. 1965-66 Lark except Station Wagon. ....**\$610.00 pr.**  
**1560440** Standard. 1962-66 Lark Station Wagon. Heavy duty for 1965-66 Lark except Station Wagon. ....**\$610.00 pr.**

**COIL SPRINGS PARTS**

**1560480** Front coil spring spacer 1/2". 1951-61 car all models & 1963-85 Avanti ...**\$22.50 ea.**



**526249** Front coil spring end pad, 1950-66 car all models, (Takes 4) ....**\$8.25 ea.**



**526830** Front coil lining spacer 1/8" thick, All **\$10.00 ea.**

NOTE: THE PRIOR INSTALLATION HEIGHT OF ANY SPRING HAS NO BEARING ON THE INSTALLED HEIGHT. GENERALLY, THE WEAKER SPRINGS ARE TALLER, THE COIL STOCK IS SMALLER, AND THE DISTANCE BETWEEN COILS IS GREATER THAN A SPRING THAT IS MADE FOR HEAVIER APPLICATIONS.

**FRONT & REAR LEAF SPRING** Related Parts

Note: Additional rear spring U-bolts are listed on page 295  
**194401** Rear leaf spring U-bolt. 5 1/4" 1939-42 Champion. ....**\$7.00 ea.**



**196638** Front spring bumper. 1939-40 Champion. Upper front on '37 Dictator 6A, '37 President, all 1938 cars, '39 Coupe Express and early 1939 Commander. ....**\$13.00 ea.**



**196712** Front leaf spring U-bolt. 5 1/4" 1939-40 Commander, 1939-42 President. ....**\$9.50 ea.**

**515274** Front spring bumper U-bolt. 1942 Commander & President. ....**\$13.00 ea.**  
**518976** Front leaf spring U-bolt, 4 1/16" 1947-49 Commander. ....**\$13.45 ea.**

**520415** Pad, rubber insulator leaf spring. All 1947-49 cars. Takes 2. ....**\$32.00 ea.**



**521517** Front leaf spring U-bolt, 3 13/16" 1947-49 Champion. ....**\$13.45 ea.**



**526675** Rear spring bumper, 1950 car. Front spring bumper, 1947-49 car. ....**\$12.00 ea.**



**529168** 4-1/2" end/end shackle, 1953-66 car ....**\$7.50 ea.**

**529169** 4" end/end shackle, 1953-66 plus 1963-85 Avanti. ....**\$7.50 ea.**  
**678730** Rear spring bumper, 1949-64 big truck. Model #13 & larger. ....**\$14.00 ea.**  
**770206** Rear spring U-bolt kit. 1951-66 all models & 1963-85 Avanti with #44 rear axle ....**\$48.00 set/4**  
**770206X1** Rear spring U-bolt kit, 1947-66 Al models w/ #23 or #27 rear axle. ..**\$72.00 set/4**  
**770210** Rear spring shackle bolt kit includes 6 bolts & nuts. 1951-57 all models. ....**\$24.00 set**  
**770210X** Rear spring shackle bolt kit includes, 6 bolts & nuts. 1958 and later cars including Avanti. ....**\$24.00 set**

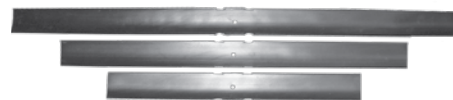

**801627** Rear spring liner kit, 1953-61 cars. Fits between rear leaf springs to reduce noise. Includes 6 liners enough for 2 springs. Will also work on later model cars to keep springs quiet. ....**\$35.00 set/6**

**1554542** Insulator pad. 1962-66 & 1963 - 85 Avanti. ....**\$2.00 ea.**

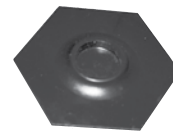

**1554546** Strap. 1962-66 various models car and 1963-85 Avanti. ....**\$12.50 ea.**



**1554550** Rubber liner for 1554546 strap. ....**\$2.50 ea.**



**1554620** Insulator pads, rear spring. 1962-66 car all models & 1963-70 Avanti. Takes 4. ....**\$3.50 ea.**



**Front Coil Springs** Car

Others available - Please call!



**526122** Front coil spring, heavy duty. 1953-66 car all models except Avanti. ....**\$205.00 pr.**  
**526127** 1955 V-8 Coupe & Hardtop and early 1956 V-8 Hawks. Except G. H. ....**\$195.00 pr.**  
**526133** 1955-58 6-cyl. Station Wagon, all and 1958 Scotsman Wagon ....**\$195.00 pr.**  
**526135** Front coil spring. 1963-85 Avanti. ....**\$205.00 pr.**  
**1539500** Most 1956 - early 1957 Champion. Except Station Wagons. ....**\$195.00 pr.**

**1541865** Late 1957 Champion. ....**\$195.00 pr.**  
**1541866** 1957 V-8 Sedan and 1958 Champion with A/C. ....**\$195.00 pr.**  
**1541868** 1958 6-cylinder Champion. All body styles with A/C. ....**\$195.00 pr.**  
**1547373** 1959-60 6-cyl. cars. Some depending on serial number. ....**\$195.00 pr.**  
**1555081** 1962 6 cylinder without air conditioning. ....**\$195.00 pr.**  
**1555082** 1962-63 Lark 6 cylinder without air conditioning, 1963 Station Wagon without A/C. 1963 6-cyl. Hawk. Europe. ....**\$195.00 pr.**  
**1555084** 1963 6-cyl. Convertible with air conditioning, 1963 sliding roof 6-cyl. Wagon with A/C. 1963 Sliding roof V-8 Wagon without A/C. 1963 Non sliding roof wagon with A/C and all 1963 V-8 Larks with A/C. ....**\$195.00 pr.**  
**1561664** Front coil spring standard duty, 1953-66 V8's all except Avanti. ....**\$242.00 pr.**

**Leaf & Coil Springs**

## FRONT SPRING BUSHINGS - Trucks Typical Front Springs

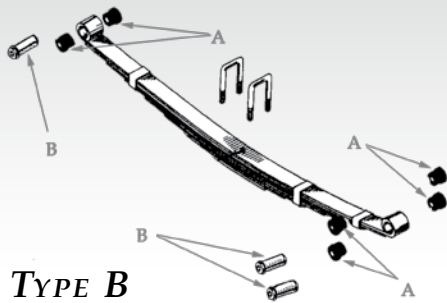

### TYPE A MODELS (12 per vehicle)

- Model M5, M15, M15A, M16, M17
- Model 2R-2E 5, 6, 7, 10, 11, 12, 13, 14, 15, 16, 17, 28, 38
- Model 3E-7E 5, 7, 10, 12

- 196643** 1941-48 M5 ..... **\$2.50 ea.**
- 524976** 1949-62 Models 5-12 .... **\$3.00 ea.**
- 677071** 1941-48 M15, 15A, 16, 17... **\$3.75 ea.**
- 677272** 1949-56 Models 13-38... **\$3.00 ea.**

### TYPE B MODELS (6 per vehicle)

- MODEL 3E-8E 13, 14, 16, 17, 25, 28, 35, 38, 40, 45
- MODEL 8E 5, 7, 10, 12

- 685029** 1957-64 Models 13-45. **\$13.50 ea.**
- 1695854** 1963-64 Models 5-12 **\$16.00 ea.**

## REAR SPRING BUSHINGS - Trucks Typical Rear Springs

### TYPE A MODELS

- Model M5, M15, M15A, M16, M17
- Model 2R5-5E 1, 2, 3, 5, 6, 7
- Model 2R-8E 13-15

- 196643** 1941-48 M5. Takes 12. .. **\$2.50 ea.**
- 524976** 1949-52 early 5 & 6 models. Takes 8. .... **\$3.00 ea.**
- 665121** 1941-48 M15. Takes 4. .... **\$8.00 ea.**
- 677223** 1949-64 2R-8E 13-45. Takes 4. .... **\$10.00 ea.**
- 677272** 1949-53 2R5 all & early 2R6. Takes 4. .... **\$3.00 ea.**
- 677272** Late 2R6, 3R 1, 2, 3, 5, 6, 7, 2R-E 10, 11, 12. Takes 12. .... **\$3.00 ea.**

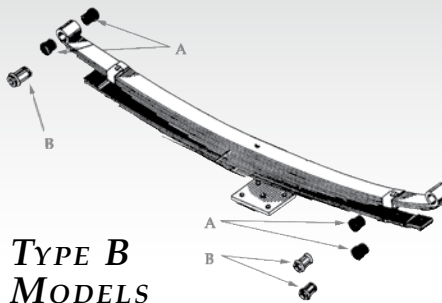

### TYPE B MODELS

- Model 2E-8E 10, 11, 12
- Model 6E-8E 5, 7
- Model 3E-4E 2, 3, 6, 7 with 4WD

- 685029** 1956-64 2E-8E Models 10, 11, 12 also 1961-64 6E-8E 5, 7, also 1957-58 3E& 4E Models 2, 3, 6 and 7 with 4WD. Takes 6. .... **\$13.50 ea.**

## CAR SPRING BUSHINGS

- (A) **196643** Rubber bushing. 1939-48 Champion & 1940-48 Commander, front & rear. 1940-42 President. .... **\$2.50 ea.**
- (A) **524976** Rubber bushing. 1949-50 car, all models, rear spring rear. .... **\$3.00 ea.**
- (B) **536517** Bushing, front of rear spring. 1955-57 car most models. 1-3/8 OD. .... **\$14.00 ea.**
- (B) **1539484** Bushing, front of rear spring. 1958-66 car, most models & 1963-85 Avanti. 1-1/2 OD. .... **\$15.00 ea.**
- (D) **1695854** Bushing, front spring. 1963-64 1/2 & 3/4 ton pickup. Takes 6. **\$16.00 ea.**

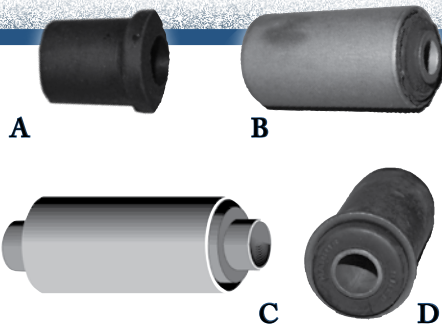

- (C) **524977** Bushing, front of rear spring. All 1949-50 cars. Takes 2. .... **\$14.00 ea.**
- (C) **1544481** Bushing, 1951-66 car, all models & 1963-85 Avanti. 7/8 OD. .... **\$12.00 ea.**

NOTE: WHEN ORDERING REAR SPRING FRONT BUSHINGS FOR CARS 1955 - 1961 (I.E. 536517, 1539484, & 1544481) IT IS RECOMMENDED THAT YOU MEASURE THE O.D. OF YOUR OLD BUSHINGS.

## SPECIAL FRONT SUSPENSION KITS FOR 1951-66 CAR ALL MODELS & 1963-85 AVANTI

### Kit includes:

- 2 king pins rebuilt with upper & lower bushings.\* 1953-60, NOS.
- 1 king pin rebuild kit containing all bearings, bushings, shims and seals for both sides\*
- 4 tie rod ends
- 2 tie rods with clamps
- 1 rebuilt center bellcrank with new pin and bearings\*\*
- 2 upper outer pin kits
- 2 lower outer pin kits
- 4 upper inner a-arm bushings
- 4 lower inner a-arm bushings
- 1951-52 only - Inner a-arm bushing kit
- 2 upper a-arm bumpers
- 2 lower a-arm bumpers
- 1 Extra long Zerk fitting

### 1951-52 CAR

**Total of all parts listed if purchased separately** ..... \$1422.00

**Special kit price** ..... **\$1351.00/kit**

—15% quantity discount. See page 4. . \$202.65

**801390R Your cost** ..... **\$1148.35/kit**

### Early 1953 - 1960 CAR & 1961 HAWK

**Total of all parts listed if purchased separately** ..... \$1282.00

**Special kit price** ..... **\$1220.00/kit**

—15% quantity discount. See page 4. . \$183.00

**801050R Your cost** ..... **\$1037.00/kit**

### 1961 LARK

### EARLY 1962 LARK & HAWK

**Total of all parts listed if purchased separately** ..... \$1341.00

**Special kit price** ..... **\$1275.00/kit**

—15% quantity discount. See page 4. . \$191.25

**802294R Your cost** ..... **\$1083.75/kit**

### Late 1962 - 66 & 1963-85 AVANTI

**Total of all parts listed if purchased separately** ..... \$1388.00

**Special kit price** ..... **\$1320.00/kit**

—15% quantity discount. See page 4. . \$198.00

**801051R Your cost** ..... **\$1122.00/kit**

**NOTE: When ordering specify year and model of car. No substitutions, or deletions.**

CORE CHARGE IS NOT DISCOUNTABLE. INVOICE MUST BE INCLUDED WITH CORE FOR REFUND.

\* REFUNDABLE CORE CHARGE OF \$200.00 APPLIES.

\*\* REFUNDABLE CORE CHARGE OF \$150.00 APPLIES.



# A-Arm Bushings, Pins, & Bumpers



**182920** Bushing. Upper inner a-arm. 1938- early 39 Commander, 1935 Commander 8, 1938-40 President. Takes 8. .... **\$6.00 ea.**

**185792**

Bushing. Upper outer a-arm pins. 1936-37 Dictator 4A & 6A, 1938-early 39 Commander & 1938-40 President. Takes 4. .... **\$24.00 ea.**

**191679** Pin. Upper outer a-arm. 1936-37 Dictator 4A & 6A, 1938-early 39 Commander, 1938 Coupe Express & 1938-40 President. Takes 2. .... **\$32.00 ea.**

**194247** Bushing. Upper inner a-arm. Late 1939 & all 1940 Commander, 1939 Coupe Express & 1939-40 President. Takes 8. .... **\$5.00 ea.**

**194347** Bushing. Upper outer a-arm pins. Late 1939 Commander, all 1939 Coupe Express, 1940 Commander & 1939-40 President. Takes 8. .... **\$6.00 ea.**

**194392** Bushing. Upper outer a-arm pin. 1939-40 Champion with #196046 pin. Takes 4. .... **\$5.00 ea.**



**195897** Pin. Upper outer a-arm. Late 1939-40 Commander & Coupe Express. Takes 2. .... **\$15.00 ea.**

**196046** Pin. Upper outer a-arm. 1939-40 Champion. Plain. Takes 2. .... **\$24.00 ea.**

**199378** Bushing. Upper outer a-arm pin. 1941-42 car, 1939-40 Champion with threaded pins & 1946 Champion. Takes 4. .... **\$15.00 ea.**

**199385** Seal, Lower pin (531192), 1951-85 car. Takes 4. .... **\$2.50 ea.**

**199388** Bushing. Upper inner a-arm. 1941-42 car except Champion. Takes 8... **\$4.50 ea.**

**199430** Pin. Upper outer a-arm. 1941-46 car. Takes 2. .... **\$24.00 ea.**

**514166** Pin. Upper outer a-arm. 1939-40 Champion. Threaded. Takes 2. .... **\$35.00 ea.**

**517563** Bumper, upper a-arm rebound. 1947-49 Champion & Commander. .... **\$28.00 ea.**

**519369** Bushing. Upper inner a-arm. 1939-46 Champion. Takes 8. .... **\$4.50 ea.**



**519877** Bumper, front spring jounce. 1947-49 all models. Takes 2. .... **\$18.00 ea.**



1963-85 Avanti. .... **\$16.50 ea.**

**524230** Bumper, lower a-arm. 1950-1966 car all models &

**525035** Seal. Upper pins (531190), 1951-85 car. Takes 4. .... **\$2.50 ea.**

**526337** Bumper, upper a-arm 1950- early 1955. .... **\$18.00 ea.**

**531179** Pin kit. Upper outer. 1950 car, all models. Includes pin, bushing & seals, zirks. .... **Use 531190**



**531180** Pin kit. Upper outer. 1947-49 car, all models. Includes pin, bushing & seals, zirks. Right or Left, check Chassis parts book. .... **\$52.00 ea.**

**531181** Right or Left, Pin kit. Upper outer. 1947-49 car, all models. Includes pin, bushing & seals, zirks. Right or Left, check Chassis parts book. .... **\$52.00 ea.**

**531182** Pin kit. Upper inner. 1947-49 car, all models. Includes pin, bushing & seals, zirks. .... **\$35.00 ea.**

**531183** Pin kit, upper Inner. 1950 Champion. Includes pin, bushing & seal, zirks. .... **\$45.00 ea.**

**531184** Pin kit. Upper Inner. 1950 Commander. Includes pin, bushing & seal, zirks. .... **\$45.00 ea.**

**531185** Pin kit. Lower Outer. 1947-50 car, all models. Includes pin, bushing & seal, zirks. .... **\$65.00 ea.**



**531186**

**531186** Pin kit. Lower inner. 1947-49 car, all models. Includes pin, bushing & seal, zirks. Pictured above. .... **\$120.00 ea.**

*If you don't see the part you want, please call (317) 462-3124 and inquire.*



**531187** Pin kit. Lower Inner. 1950 all models. Includes pin, bushing & seal, zirks. .... **\$75.00 ea.**

**531190** Pin kit. Upper Outer. 1951-66 car, all models & 1963-85 Avanti. Includes pin, bushing & seal, zirks. Pictured, above. .... **\$75.00 ea.**



**531191** Pin kit. Upper inner 1951-52 car, all models. Includes pin, bushing & seals, zirks. .... **\$75.00 ea.**

**531192** Pin kit. Lower Outer. 1951-66 car, all models & 1963-85 Avanti. Pictured, above. .... **\$75.00 ea.**

**531193** Pin kit. Lower inner 1951-52 car, all models. Includes pin, bushing & seals, zirks. .... **\$60.00 ea.**

**532181** Upper a-arm, 1953-66 car all & 1965-85 Avanti. .... **\$185.00 ea.**

**533164**



**1553430** Bushings. Lower a-arm, inner. 1953-66 car, all models & 1963-85 Avanti. Set of 4. .... **\$70.00 set/4**

**1553430** Bushings. Upper a-arm, inner. 1953-66 car, all models & 1963-85 Avanti. Set of 4. Pictured above .... **\$60.00 set/4**

**537461** Bumper. Upper a-arm. Late 1955-66 car, all models & 1963-85 Avanti. Takes 2. .... **\$12.50 ea.**



**J-2044** Spreader tool for installing pins in upper and lower a-arms. .... **\$44.00 ea.**

# A-Arm Bushings, Pins & Bumpers

## KING PIN BUSHING & BEARING SETS (Less Pins)

- S-333X1** All 1938 car & early 1939 Commander, less plugs & shims. **\$.80.00 ea.**  
**S-334X1** Late 1939-40 Commander & 1939-40 President, less shims & gaskets. All 1941-42 Commander & President. **\$.80.00 ea.**  
**S-335X1** 1934-37 Dictator & Coupe Express (A,1A, 3A,5A & J5), less gaskets & shims. **\$.80.00 ea.**  
**S-336X1** Bushing & Bearing set without plugs, shims & gaskets. 1936-37 Dictator & President 4A, 6A, 2C & 3C. **\$.80.00 ea.**  
**S-358X1** 1939-40 Champion with king pins having forging #197744/197745. Less gasket & shims. **\$.80.00 ea.**  
**S-367X1** 1941-46 Champion, less gaskets. **\$.80.00 ea.**  
**522042X1** 1947-49 Champion. **\$.80.00 ea.**  
**522043X1** Early 1947 Commander less gaskets & shims. **\$.80.00 ea.**  
**523657X1** Late 1947 & early 1948 Commander less gaskets. **\$.80.00 ea.**  
**525668X1** Late 1948 & all 1949 Commander less gaskets. **\$.80.00 ea.**  
**526844X1** 1950 Champion. .... **\$.90.00 ea.**  
**526845X1** 1950 Commander less gaskets. **\$.80.00 ea.**

## MINOR KING PIN REBUILD KIT



- 800157** 1951-66 car, all models & 1963-85 Avanti. Includes all bearings, bushings, shims & seals to rebuild both sides. **\$.105.00 ea.**

## KING PIN BUSHINGS & BEARINGS

- 140706** Upper thrust bearing. 1939-50 Champion. Late 1947-49 Commander, Truck: M16-17 & 2R-6E 16, 17, 28, 38, 40 & 7E-8E 25, 28, 35, 40 & 45. **\$.22.50 ea.**  
**165010** Upper thrust bearing. 1934-37 Dictator & 1935, 38-39 Commander & 1937-38 Coupe Express & 1935-38 President. Truck: 2R-8E 1, 2, 3, 5, 6, 7 & 2R-4E 10, 11, 12. **\$.17.50 ea.**  
**196859** Lower bearing. 1939-50 Champion, & 1951-66 all models & 1963-85 Avanti. **\$.14.00 ea.**  
**519483** King pin seal, 1947-50 Champion, 1951-66 car, all models & 1963-85 Avanti. **\$.1.50 ea.**  
**526815** Upper bushing. 1950 Champion. **\$.7.20 ea.**  
**636965** Upper thrust bearing. 1951-64 all models & 1963-85 Avanti. **\$.16.00 ea.**  
**661403** Upper thrust bearing. Truck: M15, 15A, 2R-3R 14, 15 5E-8E 10, 11, 12. **\$.24.25 ea.**

# King Pin Kits

**Kits include: Pins, bearings, & bushings to rebuild both sides.** (Unless otherwise noted)

### CAR (NOS Unless otherwise noted)



- S-334** Kit comes without gaskets. Late 1939 Commander, all 1939 Coupe Express & President, all 1940 cars except Champion. **\$.130.00/kit**  
**S-349** Early 1939 Champion with king pins having forging number: 195196/195197. Less gaskets. **\$.170.00/kit**  
**S-358** 1939-40 Champion with King pins having forging number: 197744/45. Less gaskets. Pictured, left. **\$.165.00/kit**

### CAR NOS Unless otherwise noted

- S-367** 1941-46 Champion. Less gaskets. **\$.170.00/kit**  
**S-368** 1941-42 all except Champion. **\$.180.00/kit**  
**522042** 1947-49 Champion. .... **\$.230.00/kit**  
**522043** Early 1947 Commander. **\$.105.00/kit**  
**525668** Late 1947 & all 1948-49 Commander. **\$.160.00/kit**  
**526844** 1950 Champion. Includes rebuilt king pins (2) with new upper & lower sleeves, all bearings, bushings, shims & seals for both sides. Old king pins must be sent first. **\$.450.00/kit**  
**526845** 1950 Commander. Less gaskets. **\$.160.00/kit**  
**\*529057** 1951-52 car all models. **\$.395.00/kit**  
 Refundable core charge. .... **\$.200.00 core**  
**\*800331** 1961-66 car, all models except 1961 Hawk) & 1963-85 Avanti. Includes rebuilt king pins (2) with new upper and lower sleeves, all bearings, bushings shims & seals for both sides. **\$.465.00/kit**  
 Refundable core charge\*..... **\$.500.00 core**  
**1553352** 1953-1960 car, all models & 1961 Hawk. **\$.395.00/kit**

### TRUCK

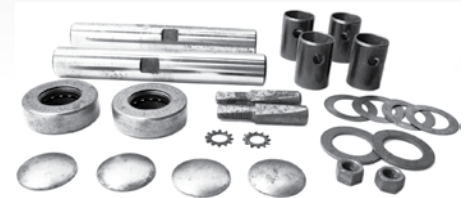

- 674533X1** Early M5 bearing & bushings only. No pins. **\$.45.00/kit**  
**674534** 1941-48. M15, early 15A. **\$.68.00/kit**  
**674535** 1941-55 M16, M17 & 2R-E 16, 17, 28, 38. **\$.90.50/kit**  
**676587** Late M15A & 1949-54 2R & 3R 14, 15, E14, 7E & 8E 13, 15. **\$.95.00/kit**  
**678171** (Pictured) Late M5 1949-64, 2R-2E 5, 7, 10-12, 3E-6E 1-3, 5-7, 3E-4E 10-12, 7E-8E 5, 7. **\$.74.00/kit**  
**684492** 1955-61 E & 2E 13, 14, 15, 3E & 4E 10, 11, 12, 13, 14, 5E & 6E 13, 14. **\$.94.60/kit**  
**684493** 1955-64 E-6E 16, 17, 28, 38, 7E & 8E 25, 28,35. **\$.110.00/kit**  
**1692875** 5E and 6E 10, 11, 12. 7E 10, 11. Pictured, above. **\$.239.00/kit**  
**1689073** 7E and 8E 40, 45 with standard front axle. **\$.93.50/kit**

**\* NOTE: Invoice must be included with core for a refund.**



# Steering Gear

## PRE-WAR STEERING

### GEAR Twin Lever Type late 1936-46

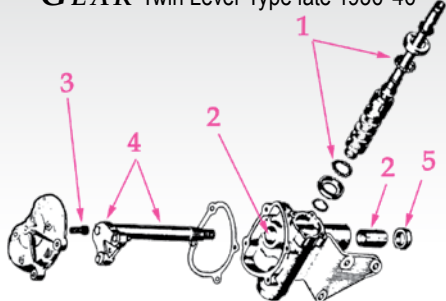

- (1) **G145641** Ball bearing. 1936-1946 all models. .... **\$6.25 set/25**
- (2) **680211** Sector shaft bushing. 1939-46 Champion. Takes 2. .... **\$11.00 ea.**
- (2) **680212** Sector shaft bushing. 1936-42 Dictator & Commander. Takes 2... **\$12.50 ea.**
- (3) **190277** Screw, adjusting. 1937-40 all except Champion. .... **\$4.95 ea.**
- (4) **198436** Sector shaft. 1940-42 Commander. .... **\$93.00 ea.**
- (5) **190276** Oil seal. 1937-42 President. .... **\$17.50 ea.**
- (5) **197106** Oil seal. 1939-46 Champion. .... **\$12.75 ea.**
- (5) **523010** Oil seal. 1936-39 car. Except President & Champion. .... **\$16.50 ea.**
- (5) **1694898** Oil seal. 1940-42 Commander. .... **\$11.00 ea.**

## Steering Gear Models 14A,15A,16A 1947-49 Commander

- (2) **196821** Nut. .... **\$12.00 ea.**
- (3) **196378** Spring. .... **\$2.20 ea.**
- (4) **521742** Bearing. 1947-48. .... **\$19.25 ea.**
- (4) **525662** Bearing. 1949. .... **\$19.25 ea.**
- (5) **515548** Cover. .... **\$17.05 ea.**
- (7) **189143** Gasket. .... **\$1.20 ea.**
- (8) **189144** Shim. .003. .... **\$2.20 ea.**
- (8) **189145** Shim. .010. .... **\$2.20 ea.**
- (9) **G114496** Nut. .... **\$1.20 ea.**
- (10) **G103865** Plug. .... **\$1.75 ea.**
- (11) **520883** Screw. .... **\$3.30 ea.**
- (12) **525907** Cover. .... **\$13.20 ea.**
- (13) **198441** Gasket. .... **\$4.95 ea.**
- (14) **521192** Sector shaft. ... **\$115.50 ea.**
- (20) **680212** Bushing. Takes 2. .... **\$12.50 ea.**

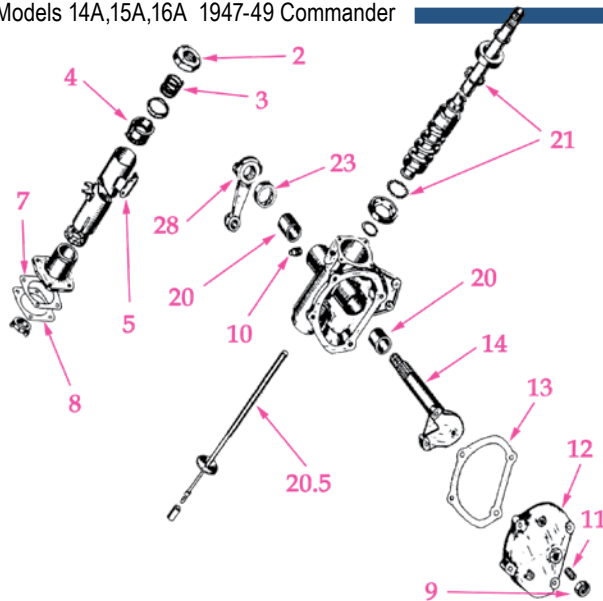

- (21) **G145641** Ball. .... **\$6.25 set/25**
- (23) **523036** Seal. Early 1947. .... **\$11.00 ea.**
- (23) **517091** Seal. Late 1947-1950. .... **\$13.20 ea.**
- (28) **521071** Arm. .... **\$31.35 ea.**
- (20.5) **1544555** Cover & tube. ... No Stock

## Steering Gear Models 6G,7G,8G 1947-49 Champion

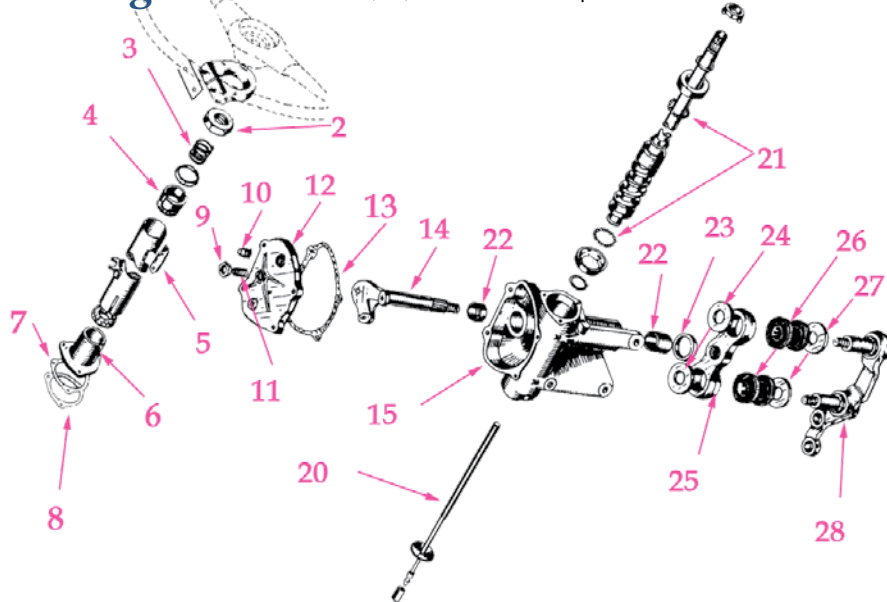

- (2) **196821** Nut. All models. .... **12.00 ea.**
- (3) **196378** Spring. All models. ... **\$2.20 ea.**
- (4) **521742** Bearing. All models. **\$19.25 ea.**
- (5) **515548** Cover. All models. ... **\$17.05 ea.**
- (5) **521979** Cover. All models. . **\$13.20 ea.**
- (7) **197108** Gasket. All models. ... **\$2.00 ea.**
- (8) **197109** Shim, (.003). .... **\$1.20 ea.**
- (8) **197110** Shim, (.010). .... No Stock
- (9) **G272121** Nut. .... **\$1.65 ea.**
- (10) **G103865** Plug. .... **\$1.75 ea.**
- (11) **197042** Screw. .... **\$4.95 ea.**
- (12) **522632** Cover. .... **\$13.70 ea.**
- (13) **521095** Gasket. .... **\$3.30 ea.**
- (14) **521092** Shaft. .... **\$104.50 ea.**
- (15) **521093** Housing. .... **\$83.60 ea.**
- (20) **521096** Cover & tube. Limited supply. .... No Stock
- (21) **G145641** Ball. .... **\$6.25 set/25**
- (22) **680211** Bushing. Takes 2. **\$11.00 ea.**
- (23) **197106** Seal. .... **\$12.75 ea.**
- (24) **523208** Upper washer. Takes 2. .... **\$2.00 ea.**
- (25) **519245** Adapter. .... **\$22.00 ea.**
- (26) **519627** Bushing. Takes 2. .... **\$7.70 ea.**
- (27) **523207** Lower washer. Takes 2. .... **\$2.00 ea.**
- (28) **519244** Arm. .... **\$71.50 ea.**

## PRE-WAR STEERING GEAR

### Pitman Arm & Adapter



- (1) **197801** Arm with studs. 1939-40 Champion. .... **\$38.50 ea.**
- (1) **199394** Arm with studs. 1941-46 Champion. .... **\$38.50 ea.**
- (2) **198123** Arm. 1939-40 Commander & President. .... **\$38.50 ea.**
- (3) **190260** Arm. Late 1936 Dictator 4A & 1937 Dictator 6A. .... **\$44.00 ea.**
- (4) **191968** Arm. 1938 Commander & Coupe Express. .... **\$42.35 ea.**
- (5) **197787** Adapter. 1939-46 Champion. .... **\$19.25 ea.**
- (6) **198127** Adapter & studs. 1940-42 Commander. .... **\$38.60 ea.**
- (7) **197789** Insulator. 1940-42 Commander, President & 1939-46 Champion. Takes 4. .... **\$3.85 ea.**

NOTE: FOR PRE-WAR STEERING PARTS NOT LISTED, PLEASE INQUIRE AS TO PRICE & AVAILABILITY. PART NUMBERS MUST BE FURNISHED.

# Steering Gear

## Steering Gear

Model 9G 1950 Champion

- (1) **196821** Nut. .... \$12.00 ea.
- (3) **196378** Spring. .... \$2.20 ea.
- (4) **521742** Bearing. Champion with standard trans. .... \$19.25 ea.
- (4) **525662** Bearing. Champion with automatic trans. .... \$19.25 ea.
- (7) **197108** Gasket. .... \$2.00 ea.
- (8) **197109** Shim. (.003)..... \$1.20 ea.
- (8) **197110** Shim. .010. .... No Stock
- (9) **G272121** Nut. .... \$1.65 ea.
- (10) **G103865** Plug. .... \$1.75 ea.
- (11) **197042** Screw. .... \$4.95 ea.
- (12) **527052** Cover. .... \$24.20 ea.
- (13) **679255** Gasket. .... \$4.95 ea.
- (14) **527048** Sector shaft. ... \$155.00 ea.
- (16) **527022** Housing. .... \$104.50 ea.
- (20) **521096** Cover & tube. .... No Stock
- (21) **G145641** Ball. .... \$6.25 set/25
- (22) **680210** Bushing. Requires modification. Takes 2. .... \$22.00 ea.
- (23) **679257** Seal. .... \$8.00 ea.
- (24) **523207** Upper washer. Takes 2. .... \$2.00 ea.

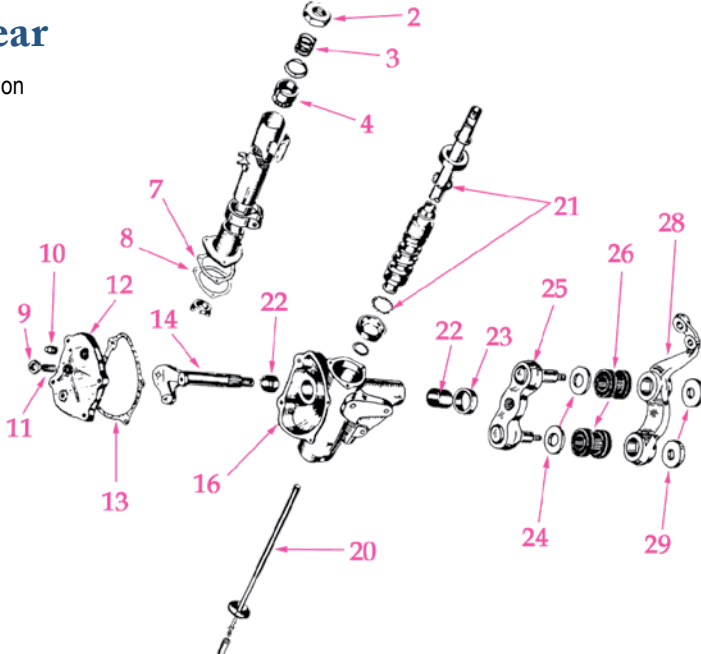

- (25) **526291** Adapter. .... \$38.50 ea.
- (26) **519627** Bushing. Takes 2. .. \$7.70 ea.
- (28) **526288** Arm. .... \$38.50 ea.
- (29) **523208** Lower washer. Takes 2. .... \$2.00 ea.

## Type "S" Steering

1951-56 car &  
1957 Champion w/3-spoke wheel

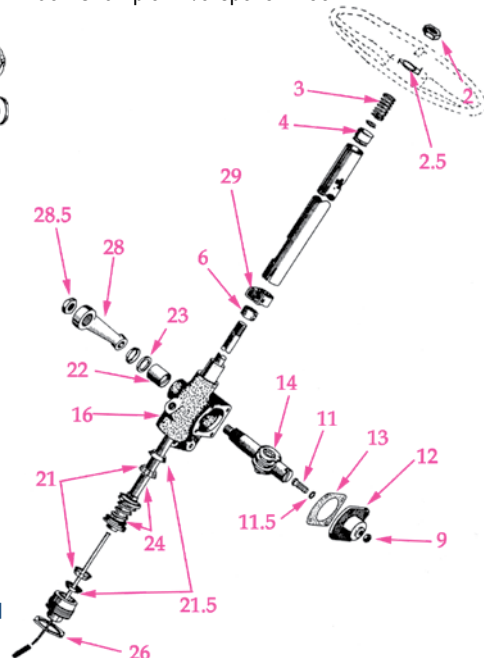

- (2) **196821** Nut. All models. .... \$12.00 ea.
- (2.5) **534451** Lock. 1953-57. .... \$4.95 ea.
- (3) **196378** Spring. 1951-52. .... \$2.20 ea.
- (3) **534227** Spring. 1953-57. .... \$2.20 ea.
- (4) **521742** Bearing. 1951 custom before serial #1,111,6111. .... \$19.25 ea.
- (4) **525662** Bearing. Late 1951 custom & all other 1951-52 car. .... \$19.25 ea.
- (4) **532449** Bearing. 1953-57. .... \$20.35 ea.
- (6) **533697** Cam. 1953-57. .... \$6.05 ea.
- (9) **G272121** Nut. .... \$1.65 ea.
- (11) **531149** Screw. All models. .... \$10.45 ea.
- (11.5) **531150X1** .063 shim. .... \$4.95 ea.
- (11.5) **531150X2** .065 shim. .... \$4.95 ea.
- (11.5) **531150X3** .067 shim. .... \$4.95 ea.
- (11.5) **531150X4** .069 shim. .... \$4.95 ea.
- \*(12) **531144** Cover. Includes bearing. .... No Stock
- (13) **531147** Gasket. .... \$4.95 ea.
- (14) **531148** Shaft. All models. .... \$150.00 ea.
- (16) **532580** Housing. All models. .... \$69.85 ea.
- (21) **531142** Bearing. All. Takes 2. .... \$13.20 ea.
- (21.5) **531141** Cup. All models. Takes 2. .... \$18.15 ea.
- (22) **531140** Bushing. All models. .... Substitute 680209 & modify.
- (23) **531351** Seal. All models. .... \$7.70 ea.
- (24) Steering shaft. .... Call for Availability
- (26) **531121** Lock nut. All models .... \$7.70 ea.
- (28) **531136** Arm. 1951-52. .... \$52.80 ea.
- (28) **532526** Arm. 1953-57 except C & K. .... \$41.80 ea.
- (28.5) **510746** Nut. .... \$4.95 ea.
- (29) **532885P** Clamp. All models. .... \$4.95 ea.

## Steering Gear Model 17A 1950 Commander & Land Cruiser

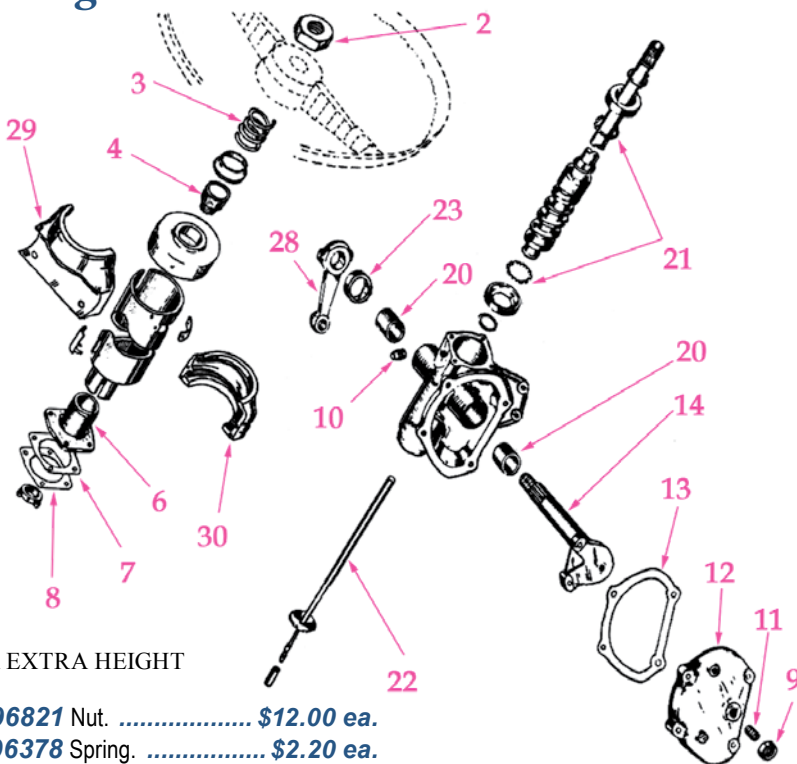

\* FOR EXTRA HEIGHT

- (2) **196821** Nut. .... \$12.00 ea.
- (3) **196378** Spring. .... \$2.20 ea.
- (4) **525662** Bearing. .... \$19.25 ea.
- (6) **527413** Cover. .... \$19.25 ea.
- (7) **189143** Gasket, (.002). .... \$1.20 ea.
- (8) **189144** Shim, (.003). .... \$2.20 ea.
- (8) **189145** Shim, (.010). .... \$2.20 ea.
- (9) **G114496** Nut. .... \$1.20 ea.
- (10) **G103865** Plug. .... \$1.75 ea.
- (11) **520883** Screw. .... \$3.30 ea.
- (12) **525907** Cover. .... \$13.20 ea.
- (13) **189133** Gasket. .... \$4.95 ea.
- (14) **521192** Shaft. .... \$115.50 ea.
- (20) **680212** Bushing. Takes 2. .... \$12.50 ea.
- (21) **G145641** Ball. .... \$6.25 set/25
- (22) **1544555** Cover & Tube. .... No Stock
- (23) **1694898** Seal. .... \$11.00 ea.
- (28) **526103** Arm. .... \$31.35 ea.
- (29) **291590** Bracket. Chrome. .... \$71.50 ea.
- (29) **291060\*** Bracket. Chrome. .... \$71.50 ea.
- (30) **291059** Bracket. Chrome. .... \$71.50 ea.

\* 680209 BUSHING CAN ALSO BE SUED TO REPLACE THE BUSHING IN YOUR OLD COVER.



## Standard Steering Gear Type SL 1957-64

- (1) **3091X2** Nut. .... **\$3.85 ea.**
- (2) **1541970** Bearing. 1957-59 shift lever support. .... **\$16.50 ea.**
- (2) **1550908** Bearing. 1960 & all 1961-64 with type-C shift lever support. ... **\$19.25 ea.**
- (3) **1541967** Bracket with bearing. 1957-59 car & 1960. with type -B shift lever support. .... **\$43.45 ea.**
- (3) **1550904** Bracket with bearing. 1960 car with type-C shift lever support. ... **\$43.45 ea.**
- (3) **1553319** Bracket with bearing. All 1961-64 car. .... **\$63.25 ea.**
- (4) ..... Call for Availability & price
- (5) **532885P** Clamp. All models. **\$4.95 ea.**
- (6) **532994P** Bracket. 1957-60 all models, 1961-64 Hawk. .... **\$10.45 ea.**
- (7) **189143** Gasket. All models. Brass. .... **\$1.20 ea.**
- (8) **189144** Shim, (.003). all models **\$2.20 ea.**
- (8) **189145** Shim, (.010). all models. **\$2.20 ea.**
- (9) **1542673** Post. 1957-64 Hawk. .... **\$150.00 ea.**
- (10) **1542662** Housing. 1958-60 V-8 Lark & sedan and 1960 6-cylinder convertible. .... **\$71.50 ea.**
- (10) **1542663** Housing. 1957-64 Hawk. .... **\$71.50 ea.**

- (11) **G444734** Plug. All models. **\$1.10 ea.**
- (12) **1541938** Arm. 1957-60 V-8 all models, 1959 6-cylinder Hawk & convertible. 1553208 arm, 1961 6-cylinder Lark. .... **\$42.35 ea.**
- (12) **1551387** Arm. 1961-64 Hawk. .... **\$42.35 ea.**
- (13) **168093** Nut. All models. .... **\$4.95 ea.**
- (14) **190276** Seal. All models. .... **\$17.50 ea.**
- (15) **680209** Bushing. All models. Requires modification. Takes 2. .... **\$16.50 ea.**
- (16) **1543133** Sector shaft. All models. Includes stud. & rollers. .... **\$126.50 ea.**
- (17) **1542670** Gasket. All models. .... **\$4.95 ea.**
- (18) **1542669** Cover. All models. .... **\$31.35 ea.**
- (19) **630651** Screw. All models. .... **\$2.20 ea.**
- (20) **G124934** Nut. .... **\$1.10 ea.**
- (21) **1543135** Stud & roller kit. .... Call for availability & price
- (22) **1544555** Cover & tube. All models No Stock
- 1541790** Complete Steering Gear for 1957-64 Hawk. Numbers 9 through 22. .... **\$650.00 ea.**

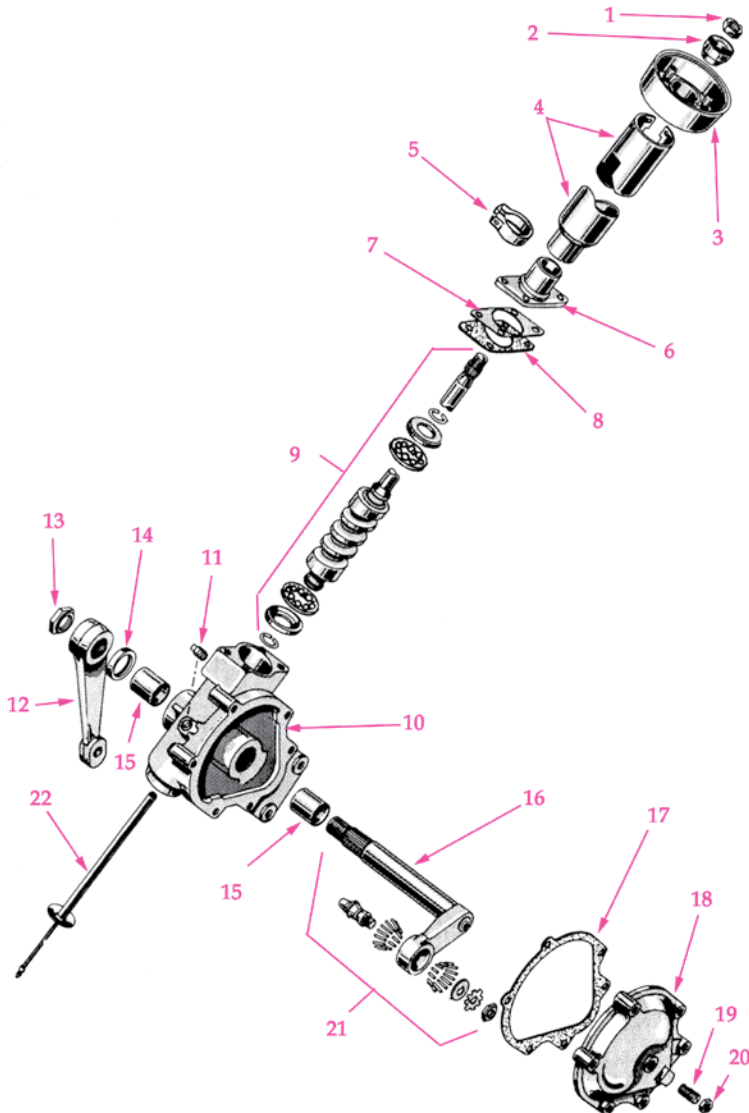

## Steering Gear Types: TA-TL, "TA" used in 1951-54 Car "TL" used in 1951-56 CAR, All & 1957-58 Champion

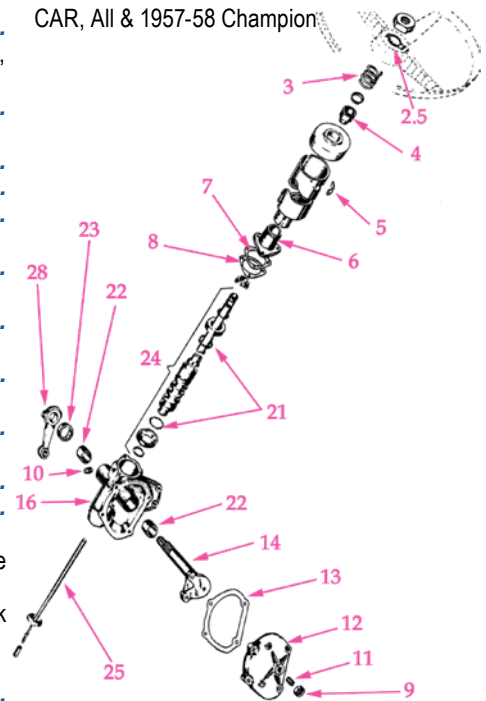

- (2) **196821** Nut. 1951-58. .... **\$12.00 ea.**
- (2.5) **534451** Lock plate. 1953-58. .... **\$4.95 ea.**
- (3) **196378** Spring. 1951-52. .... **\$2.20 ea.**
- (3) **534227** Spring. 1953-58. .... **\$2.20 ea.**
- (4) **521742** Bearing. 1951 customs before serial #G1,111,611. .... **\$19.25 ea.**
- (4) **525662** Bearing. 1951 customs after serial #G1,111,611 & all other 1951-52 car. ... **\$19.25 ea.**
- (5) **515548** Cover. 1951 custom before serial #G1,111,61. .... **\$17.05 ea.**
- (5) **530062P** Cover. Late 1951 custom & all other 1951-52 car. .... **\$6.60 ea.**
- (6) **532473** Flange. 1953-58. .... **\$13.20 ea.**
- (7) **197108** Gasket. All models. .... **\$2.00 ea.**
- (8) **197109** .003 shim. All models. .... **\$1.20 ea.**
- (8) **197110** .010 shim. All models. No Stock
- (9) **G272121** Nut. TA. .... **\$1.65 ea.**
- (9) **G114496** Nut. TL. .... **\$1.20 ea.**
- (11) **197042** TA screw for 530902 shaft. .... **\$4.95 ea.**
- (11) **630651** TL screw for 532273 shaft. .... **\$2.20 ea.**
- (12) **530912** Cover. TA. 1951-54. all models .... **\$24.20 ea.**
- (12) **530914** Cover. TL. 1951-54. all models. .... **\$28.05 ea.**
- (13) **679255** Gasket. TA. 1951-54. .... **\$4.95 ea.**
- (13) **530916** Gasket. TL. 1951-58. .... **\$4.50 ea.**
- (14) **530902** Shaft. TA. 1951-54. Champion except C & K. .... **\$93.50 ea.**
- (14) **532273** Shaft. TL. 1951 all models, 1952 Commander & '53-'58 all models '53 & '54 Champion C & K only. .... **\$95.00 ea.**
- (21) **G145641** Ball, set of 25. All models. .... **\$6.25 set/25**
- (22) **680210** Bushing, all models. Requires modification. Takes 2. .... **\$22.00 ea.**
- (23) **679257** Seal, all models. ... **\$8.00 ea.**
- (24) Steering shaft. .... Call
- (25) **530907** Cover & tube, TL box only. 1951-58. .... **\$10.45 ea.**
- (28) **529327** Arm. TA & TL. 1951-52. .... **\$38.50 ea.**
- (28) **532525** Arm. TA & TL. 1953-58. .... **\$43.45 ea.**

# Steering Gear

# Steering Gear

## Standard Steering Gear Type S 1961-66 Lark

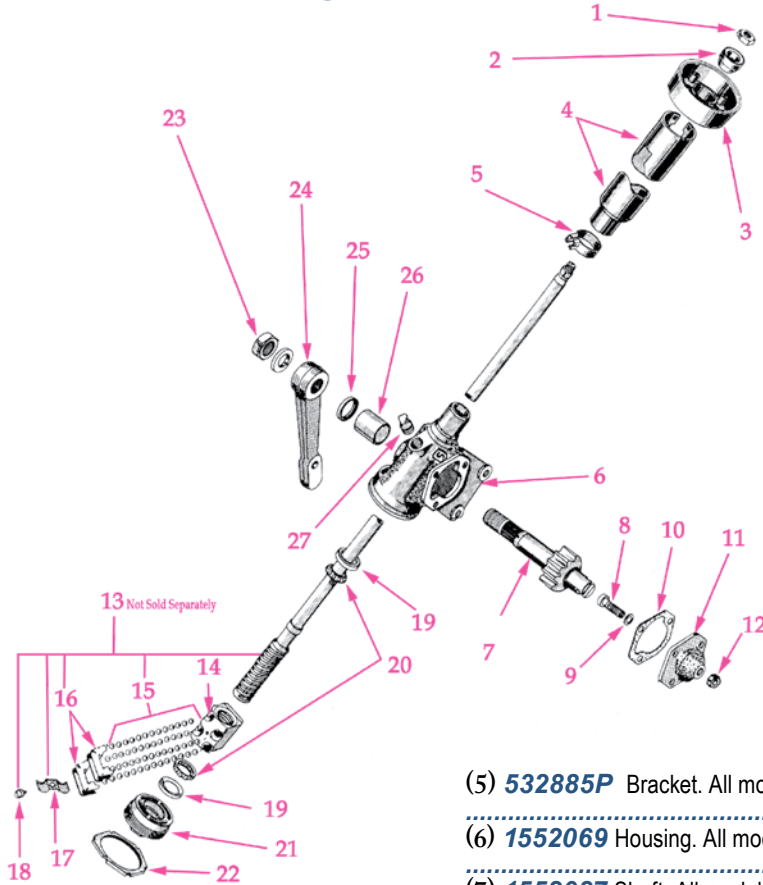

- (1) **3091X2** Nut. .... **\$3.85 ea.**
- (2) **1550908** Bearing. All models.. **\$19.25 ea.**
- (3) **1553319** Bracket. All models.. **\$63.25 ea.**
- (4) Jacket. .... Call

- (5) **532885P** Bracket. All models. .... **\$4.95 ea.**
- (6) **1552069** Housing. All models. .... **\$71.50 ea.**
- (7) **1552087** Shaft. All models. .... **\$93.50 ea.**
- (8) **531149** Screw. All models. .... **\$10.45 ea.**
- (9) **1552086** Shim kit. All models. .... **\$10.45 ea.**
- (10) **1552076**..... No Stock
- (11) **1552075** Cover with bushing. .... **\$27.50 ea.**
- (12) **G272121** Nut. .... **\$1.65 ea.**

- (13) **1552077** Shaft 20:1 ratio. 1961-66 6-cylinder with power steering. .... No Stock
- (13) **1552078** Shaft 24:1 ratio. 1961-66 V-8 w/o power steering. .... **\$86.75 ea.**
- (14) **1552079** Ball nut goes with 1552077 shaft 20:1 ratio. .... **\$55.00 ea.**
- (14) **1552080** Ball nut goes with 1552078 shaft 24:1 ratio. .... **\$46.20 ea.**
- (15) **1552496** Ball set. All models. .... **\$27.50 ea.**
- (16) **1552081**..... No Stock
- (16) **1552082** Guide goes with 1552078 shaft 24:1 ratio. Takes 4. .... **\$3.30 ea.**
- (17) **1552084** Clamp. 1961-66 V-8 without power steering. .... **\$4.95 ea.**
- (18) **G187385** Screw. 1961-66 6-cylinder & 1961-66 V-8 with power steering. .... **60¢**
- (18) **1552085** Screw. 1961-66 V-8 without power steering. .... **\$4.95 ea.**
- (19) **1552072** Thrust bearing. All models except early 1961 V-8. Takes 2. .... **\$7.70 ea.**
- (20) **1552073** Cup, thrust bearing. 1961-66 All models except early 1961 V-8. Takes 2. .... **\$13.20 ea.**
- (21) **1565140** Adjustor. 1961-66 All models except early 1961 V-8. .... **\$33.00 ea.**
- (22) **1552071** Adjustor nut. All models. .... **\$7.70 ea.**
- (23) **1553103** Nut. All models. .... **\$7.70 ea.**
- (24) **1553208** Pitman arm. 1961-64 V-8 except sliding roof wagon. .... **\$42.35 ea.**
- (24) **1551387** 1961-64 V-8 convertible & 1963-64 sliding roof wagon ..... **\$42.35 ea.**
- (25) **1552088** Seal. All models. .... **\$11.25 ea.**
- (26) **531140** Bushing. All models. .... Substitute 680209 & modify.
- (27) **G444746** Plug. All models. .... **\$2.75 ea.**

## Steering Linkage Models 14A, 15A, 16A, 1947-49 Commander

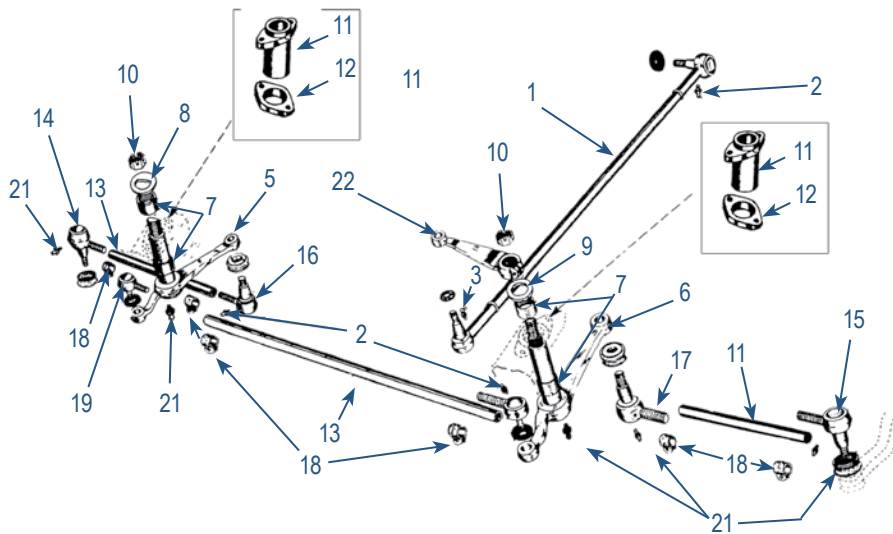

- (1) **520115** Drag Link. 1947-49 All. .... **\$52.00 ea.**
- (2) **718-04** (G110347) Grease fitting. .... **\$1.95 ea.**

- (3) **738-04** (G110309) Grease fitting. .... **\$2.75 ea.**

- (5) **519110** Bellcrank. Right. .... **\$83.60 ea.**
- (6) **519111** Bellcrank. Left. Not perfect. .... Call
- (7) **518390** Bearing. Takes 4. ... **\$19.25 ea.**
- (8) **184808** Thrust washer. .... **\$4.95 ea.**
- (9) **519470** Thrust washer. .... **\$11.55 ea.**
- (10) **260-12** (G6427639) Nut. ... **\$6.60 ea.**
- (11) **522523** Bracket. Includes 2 #518390 BRGS. .... **\$53.35 ea.**
- (12) **522492** Collar. .... **\$16.50 ea.**
- (13) **518904** Rod. .... **\$22.00 ea.**
- (14) **520110** End, outer right tie rod. .... Substitute 520111
- (15) **520111** End, outer left tie rod **\$90.00 ea.**
- (16) **520112** End, inner right tie rod. .... **\$45.00 ea.**
- (17) **520113** End, inner left tie rod **\$45.00 ea.**
- (18) **510487** Clamp, less bolt and nut. .... **\$4.40 ea.**
- (19) **520345** Auxiliary rod end. Right. .... **\$38.00 ea.**
- (20) **520346** Auxiliary rod end. Left. .... **\$45.00 ea.**
- (21) **716-02** (G443753) Grease fitting. .... **\$1.65 ea.**
- (22) **521070** Lever. .... **\$43.00 ea.**



# Tie Rods & Related Parts

1940-42 Commander & President & late 1940-46 Champion

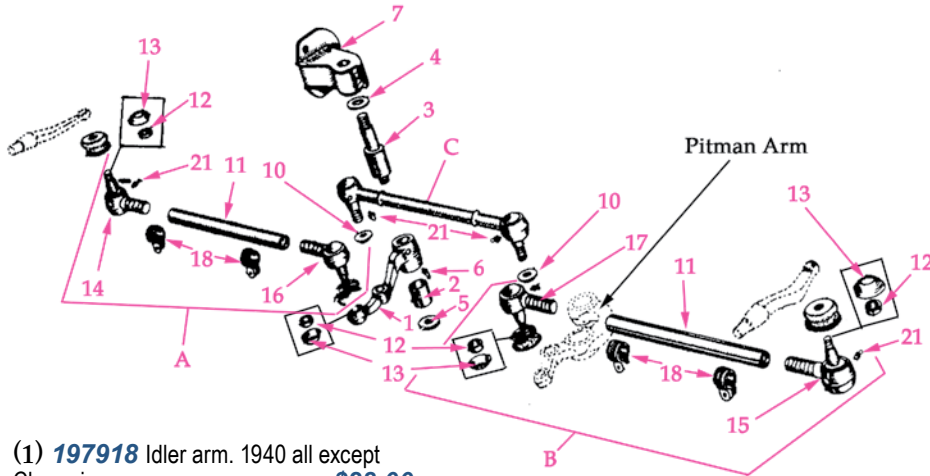

- (1) **197918** Idler arm. 1940 all except Champion. .... **\$28.00 ea.**  
*NOTE: ORDER 196591 WASHER ALSO AT \$2.50.*
- (1) **198074** Idler arm. Late 1940 Champion. .... **\$32.00 ea.**
- (1) **513502** Idler arm. 1941-46 Champion all models. .... **\$22.00 ea.**
- (1) **513508** Idler arm. 1941 Commander, late 1941 President & all 1942 cars except Champion. .... **\$24.00 ea.**
- (1) **513519** Idler arm. 1941 Commander and early 1941 President. ....  
Sub 513508 arm & one 513504 shaft. ....
- (2) **196592** Bushing, idler arm. 1940 all car except Champion. .... **\$9.90 ea.**
- (2) **198076** Bushing, idler arm. Early 1941 Commander, late 1940 Champion & all 1941 Champion. .... **\$5.50 ea.**
- (3) **197426** Pin. 1940 all cars except Champion. .... **\$9.90 ea.**
- (3) **198077** Shaft. Late 1940 Champion, early 1941 Champion & early 1941 Commander. .... **\$14.30 ea.**
- (3) **513504** Shaft. Late 1941 Commander & President, 1942 Commander & President all, late 1941 Champion & all 1942-46 Champion. .... **\$27.50 ea.**

- 513505** Bushing, idler arm. Late 1941-42 Commander, 1941-46 Champion and 1939-40 Champion with type A auxiliary arm kit. .... **\$22.00 ea.**
- (4) **195275** Thrust washer. 1940 all except Champion. .... **\$3.30 ea.**
- (4) **198078** Thrust washer. All 1941-46 car. .... **\$3.30 ea.**
- (5) **198079** Thrust washer. 1941-46 cars all models. .... **\$3.85 ea.**
- (6) **634069** Grease fitting, 67 1/2. All 1940 car except Champion ..... No Stock
- (6) **G191350** Grease fitting. All 1939-46 Champion. .... **\$2.65 ea.**
- (7) **197924** Bracket. 1940 Commander & President. .... **\$44.00 ea.**
- (7) **199861** Bracket. 1941-46 all. .... **\$27.50 ea.**
- (A) **513301** Left, tie rod assembly, complete. 1941-42 all except Champion. .... **\$135.00 ea.**
- (A) **513450** Tie rod assembly, complete. Right side. 1940 all except Champion. .... **\$109.50 ea.**
- (A & B) **198180** Tie rod assembly, complete. Right or left side, 1940-46 Champion ..... **\$105.00 ea.**

- (B) **513302** Tie rod assembly, complete. Left side. 1941-42 all except Champion. .... **\$135.00 ea.**
- (B) **513451** Tie rod assembly, complete. Left side. 1940 all except Champion. .... **\$109.50 ea.**
- (C) **198579** Tie rod and ends. 1940-42 all except Champion. .... **\$65.00 ea.**
- (C) **198588** Tie rod and ends. 1941-46 Champion. .... **\$65.00 ea.**
- (10) **192903** Seal, ball stud. 1940-42 all except Champion. .... **\$3.85 ea.**
- (11) **198020** Rod only. 1940 Commander. .... **\$24.75 ea.**
- (11) **198082** Rod only. 1940-46 Champion. .... **\$22.00 ea.**
- (11) **198258** Rod only. 1941-42 all except Champion. .... **\$27.50 ea.**
- (11) **513455** Rod only. 1940 President. ....  
No Stock
- (12) **194373** Rubber seal or washer. 1940-46 Champion. .... **\$2.20 ea.**
- (13) Cover. .... Not Available
- (14) **520112** Tie rod end, outer right. 1940-42 all except Champion. .... **\$45.00 ea.**
- (15) **520113** Tie rod end, outer left. 1940-42 all except Champion. .... **\$45.00 ea.**
- (14 & 15) **199207** End, right or left outer. 1940-46 Champion. .... **\$40.00 ea.**
- (16) **520110** Tie rod end, inner right. 1940-42 all except Champion. .... Substitute 520111
- (17) **520111** Tie rod end, inner left. 1940-42 all except Champion. .... **\$90.00 ea.**
- (16 & 17) **199208** End, right or left inner. 1940-46 Champion. .... **\$80.00 ea.**
- (18) **510487** Clamp. 1940-42 all except Champion. .... **\$4.40 ea.**
- (21) **G109350** Grease fitting. 1940-42 all except Champion. .... **\$1.95 ea.**
- (21) **G110347** Grease fitting. 1941-42 all except Champion. .... **\$1.95 ea.**
- (21) **G191350** Grease fitting. All 1939-46 Champion. .... **\$2.65 ea.**
- (21) **G443753** Grease fitting. Straight. 1940-42 all except Champion. .... **\$1.65 ea.**

# Tie Rods & Related Parts

1938 All Cars & early 1939 Commander

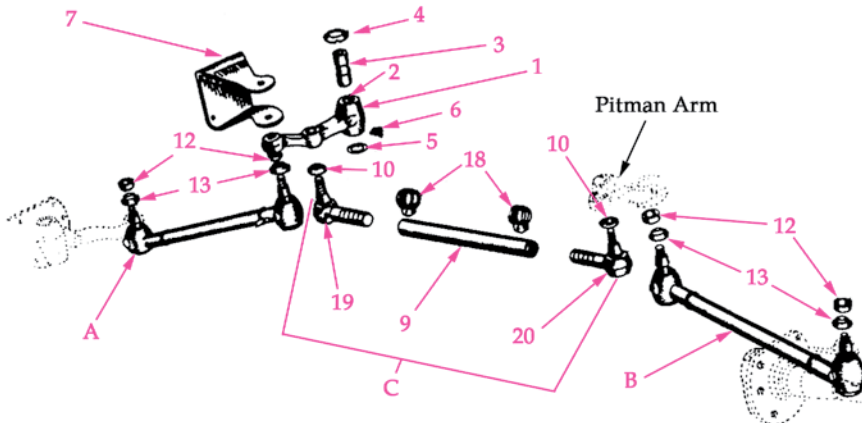

- (1) **191833** Arm with bushing. 1938 all & early 1939 Commander ..... **\$32.00 ea.**
- (2) **516768** Auxiliary arm bushing. 1938 all & very early 1939 cars. .... **\$13.20 ea.**
- (2) **193884** Bushing. Early 1939 Commander. .... **\$14.30 ea.**

- (3) **191804** Pin. 1938 all & early 1939 cars. .... **\$13.20 ea.**
- (4) **191805** Washer, upper. 1938 all & early 1939. .... **\$4.40 ea.**
- (5) **191806** Washer, lower. 1938 all & early 1939. .... **\$4.40 ea.**

- (6) **634049** Grease fitting. 67 1/2". All. ....  
No Stock
- (7) **191971** Bracket. All. .... **\$44.00 ea.**
- (A) **193383** Rod with ends, right. 1938-39 all ..... Call
- (B) **193384** Rod with ends, left. 1938-39 all. .... Call
- (C) **193134** Rod with ends. 1938-39 all. .... **\$103.80 ea.**
- (9) **192268** Rod only. 1938-39 all. ....  
No Stock
- (10) **192903** Seal, tie rod end. 1938-39 all. .... **\$3.85 ea.**
- (12) **184234** Seal. 1938-39 all. .... No Stock  
*NOTE: AVAILABLE ONLY WITH TIE ROD*
- (13) **184177** Cover. 1938-39 all ..... No Stock  
*NOTE: AVAILABLE ONLY WITH TIE ROD*
- (18) **510487** Clamp. 1938-39 all. ....  
Takes 2. .... **\$4.40 ea.**
- (19) **520345** End, complete. Right side. 1938-39 all. .... **\$38.00 ea.**
- (20) **520346** End, complete. Left side. 1938-39 all. .... **\$45.00 ea.**

# Tie Rod Assemblies

(317) 462-3124 • FAX (317) 462-8891

## Tie Rods & Related Parts 1939 All (Except early 1939 Commander & early 1940 Champion)

NOTE: SOME 1939 & EARLY 1940 CHAMPIONS HAVE BEEN UPDATED TO 1941 & LATER STANDARDS. THESE CARS WILL REQUIRE LATER PARTS.

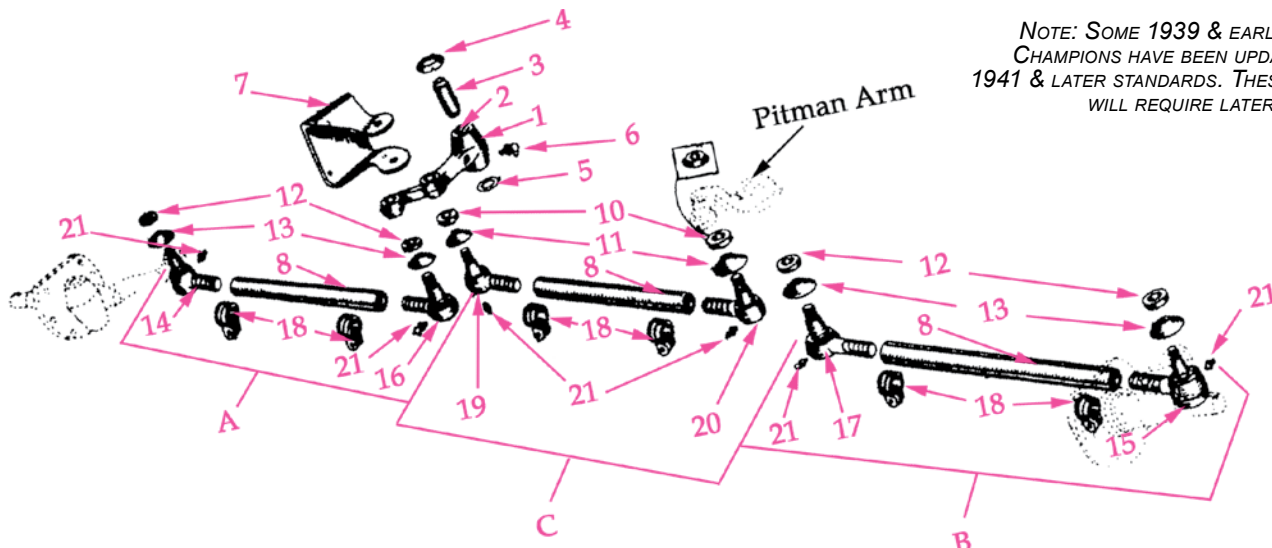

(1) **196593** Arm with bushing. Late 1939 Commander, Coupe Express, all, & President. **\$28.00 ea.**

Note: Order 196591 washer also at \$2.50.

(1) **197650** Arm with bushing. Early 1939 Champion, & 1940 Champion, all. **\$24.00 ea.**

(2) **196592** Bushing. Late 1939 car all except Champion **\$9.90 ea.**

(2) **197654** Bushing. 1939 Champion all & early 1940 Champion. **\$4.95 ea.**

(3) **197426** Pin. Late 1939 Commander & 1939 President & Coupe Express all **\$9.90 ea.**

(3) **195208** Pins. Early 1939 Champion **Not Available**

(3) **197655** Pin. Late 1939 Champion & early 1940 Champion. **\$21.95 ea.**

(4) **196591** Washer. Late 1939 Commander & 1939 President & Coupe Express all **\$3.85 ea.**

(4) **197385** Washer. 1939 Champion all & early 1940 Champion **\$3.30 ea.**

(5) **195275** Washer. 1939 car all models except Champion **\$3.30 ea.**

(5) **195211** Washer. 1939 Champion all & early 1940 Champion **\$3.85 ea.**

(6) **634069** Grease fitting. 1939 all except Champion. **No Stock**

(6) **G191350** Grease fitting. 1939-46 Champion, 1941-42 Commander & President. **\$2.65 ea.**

(7) **197736** Bracket Kit. Late 1939 Commander, 1939 President & Coupe Express all. Includes small parts. **\$60.50 ea.**

(7) **199861** Bracket. 1939-40 Champion all **\$27.50 ea.**

(A) **513446** Tie rod & ends. Right side. Late 1939 Commander, 1939 President & Coupe Express all. **\$115.00 ea.**

(B) **513447** Tie rod & ends. Left side. Late 1939 Commander, all 1939 President & Coupe Express. **\$115.00 ea.**

(A & B) **198180** Tie rod, with ends. 1939-46 Champion all. Takes 2. **\$105.00 ea.**

(8) **198082** Rod only. 1939-40 Champion all **\$22.00 ea.**

(8) **513455** Rod only. Late 1939 Commander, 1939 President & Coupe Express all. **No Stock**

(9) **192268** Rod only. 1939 all cars except Champion. **No Stock**

(10) **192903** Seal only. Auxiliary tie rod ends. 1939 cars all models except Champion. Takes 2. **\$3.85 ea.**

(10) **194373** Seal, auxiliary tie rod end. 1939-40 Champion all. Takes 2. **\$2.20 ea.**

(11) **197090** Cover, ball stud, 1939-40 Champion all. Takes 2. **Call**

(11) **193831** Cover, ball stud. Late 1939 Commander, 1939 President & Coupe Express all. Takes 2. **Call**

(12) **193832** Seal, tie rod. Late 1939 Commander, 1939 Coupe Express all **No Stock**

(13) **193831** Cover, ball stud. Late 1939 Commander, 1939 President & Coupe Express all. Takes 4. **Call**

(13) **197090** Cover, ball stud. 1939-40 Champion all. Takes 4. **Call**

(14) **520112** Tie rod end. Outer right. Late 1939 Commander, 1939 President & Coupe Express all. **\$45.00 ea.**

(15) **520113** Tie rod end. Outer left. Late 1939 Commander, 1939 President & Coupe Express all. **\$45.00 ea.**

(14 & 15) **199207** End. Right & left outer. Champion 1939-40 all. **\$40.00 ea.**

(16) **520110** Tie rod end. Inner right. Late 1939 Commander, 1939 President & Coupe Express all. **Substitute 520111**

(17) **520111** Tie rod end. Inner left. Late 1939 Commander, 1939 President & Coupe Express all. **\$90.00 ea.**

(16 & 17) **199208** End. Right & left inner. 1939-40 Champion all. **\$80.00 ea.**

(18) **510487** Clamp. Late 1939 Commander, all 1939 President & Coupe Express. **\$4.40 ea.**

(C) **193134** Auxiliary tie rod assembly with ends. 1939 all cars except Champion. **\$103.80 ea.**

(C) **197157** Rod, includes ends. 1939 Champion & early 1940 Champion. **\$95.00 ea.**

(C) **198588** Rod, includes ends. Late 1940 Champion. **\$65.00 ea.**

(19) **520345** End, right auxiliary. 1939 all cars except Champion. **\$38.00 ea.**

(20) **520346** End, left auxiliary. 1939 all cars except Champion. **\$45.00 ea.**

(19) **199207** End, right auxiliary. Early 1939-40 Champion. **\$40.00 ea.**

(20) **199208** End, left auxiliary. Early 1939-40 Champion. **\$80.00 ea.**

(21) **G109350** Fitting. 67-1/2°. All except Champion. **\$1.95 ea.**

(21) **G443753** Fitting. Straight. All except Champion. **\$1.65 ea.**

(21) **G191358** Fitting. 1939-40 Champion. **\$2.65 ea.**

### FRONT AXLE - STEERING KNUCKLE, CONTROL ARMS, & KING PINS

1936-37 Dictator & President Models 4A, 6A - 2C, 3C. Pictured - Right

(1) **S-336X1** Bushing & bearing kit. Less pins, shims & gaskets. Enough for both sides. **\$80.00 ea.**

(2) **127047** Plug, all. Takes 4. **No Stock**

(3) **510869** Bushing. 1937 Dictator 6A & all 1936-37 Presidents. Takes 4. **\$12.00 ea.**

(4) **171513** .051 - .054 shim. All. **\$2.20 ea.**

(5) **165010** Bearing. All. Takes 2. **\$17.50 ea.**

(6) **510141** Key. All. Takes 2. **\$6.50 ea.**

(7) **182920** Rubber bushing. All. Takes 8. **\$6.00 ea.**

(8) **191679** Pin. All. Takes 2. **\$32.00 ea.**

(9) **185792** Bushing. All. Takes 4. **\$24.00 ea.**

(10) **G443753** Grease fitting. Takes 2. **\$1.65 ea.**

(11) **130986** Washer. All. Takes 2. **\$4.50 ea.**

(12) **510292** Nut. 1936-37 Dictator & 1937 President. **\$6.60 ea.**



# Driveshaft Center Support Individual Pieces & Complete Kits

## 1947-49 CARS - ALL MODELS & 1950 CHAMPION (Early Canadian production)

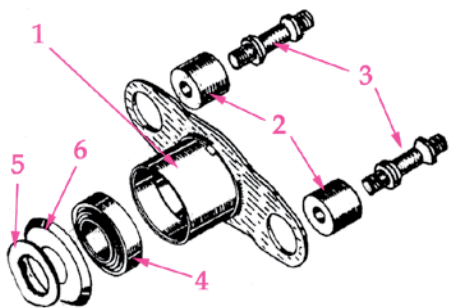

- (1) **519171** Support ..... \$24.00 ea.
- (2) **519175** Support cushion. Takes 2. .... \$5.50 ea.
- (3) **524184** Support stud. Takes 2. .... \$22.00 ea.
- (4) **517450** Bearing ..... \$42.00 ea.
- (5) **519176** Dust shield ..... \$6.00 ea.

### DRIVESHAFT CENTER SUPPORT KIT

Includes all of the following:

- (1) **519171** Support (1)
- (2) **519175** Support cushion (2)
- (3) **524184** Support stud (2)
- (4) **517450** Bearing (1)
- (5) **519176** Dust shield (1)

**Total of all parts if purchased separately.** ..... \$132.50

**801823**  
**Special kit price** ..... \$121.00/kit

*Please use your customer number when ordering. Found on the upper left hand corner of the address label on this catalog.*

## 1950 ALL MODELS (Except early Canadian-built champions)

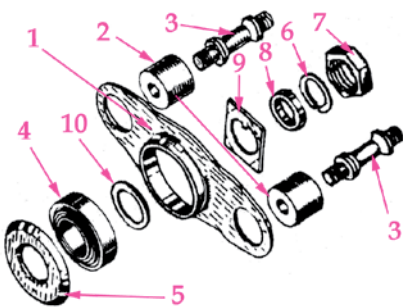

- (1) **526842** Support ..... \$23.00 ea.
- (2) **519175** Support cushion. Takes 2. .... \$5.50 ea.
- (3) **524184** Support stud. Takes 2. .... \$22.00 ea.
- (4) **664443** Bearing ..... \$46.50 ea.
- (5) **523000** Dust shield ..... \$6.00 ea.
- (6) **522051** Nut ..... \$7.55 ea.
- (7) **522054** Retainer ..... No stock
- (8) **522053** Washer ..... No Stock
- (9) **522052** Lock plate ..... No stock
- (10) **527024** Spacer ..... No stock

### DRIVESHAFT CENTER SUPPORT KIT

Includes all of the following:

- (1) **526842** Support (1)
- (2) **519175** Support cushion (2)
- (3) **524184** Support stud (2)
- (4) **664443** Bearing (1)
- (5) **523000** Dust shield (1)
- (6) **522051** Nut (1)
- (7) **522054** Retainer. No stock (0)
- (9) **522052** Lock plate. No stock (0)
- (10) **527024** Spacer. No stock (0)

**Total of all parts if purchased Separately.** ..... \$138.05

**801825**  
**Special kit price** ..... \$131.00 /kit

## 1951-57 CARS

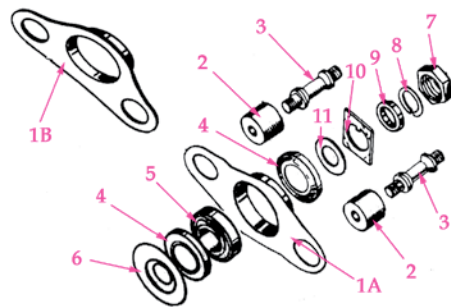

- (1A) **531746** Support, 1951-52 all. .... \$23.00 ea.
- (1B) **532009** Support, 1953-57 all ..... \$23.00 ea.
- (2) **519175** Support cushion. Takes 2. .... \$5.50 ea.
- (3) **524184** Support stud. Takes 2. .... \$22.00 ea.
- (4) **531016** Dust shield, inner. Takes 2 ..... \$4.35 ea.
- (5) **664443** Bearing, drive shaft support . .... \$46.50 ea.
- (6) **530421** Dust shield, outer. .... \$4.35 ea.
- (7) **522051** Nut ..... \$7.55 ea.
- (8) **522054** Retainer ..... No Stock
- (9) **522053** Washer ..... No Stock
- (10) **522052** Lock plate ..... No Stock
- (11) **527024** Spacer ..... No stock

### DRIVESHAFT CENTER SUPPORT KIT

Includes all of the following (A or B):

- (1A) **531746** Support, 1951-52 (1)
- or (1B) **532009** Support, 1953-57 (1)
- (2) **519175** Support cushion (2)
- (3) **524184** Support stud (2)
- (4) **531016** Dust shield, inner (2)
- (5) **664443** Bearing, drive shaft support (1)
- (6) **530421** Dust shield, outer (1)
- (7) **522051** Nut (1)
- (8) **522054** Retainer No stock (0)
- (10) **522052** Lock plate. No stock (0)
- (11) **527024** Spacer. No stock (0)

**Total of all parts if purchased separately.** ..... \$145.10  
**801824**  
**Special kit price** ..... \$138.00/kit

# Front Axle - Steering Knuckle, Control Arms, & King Pins

1936-37 Dictator & President Models 4A. 6A - 2C. 3C

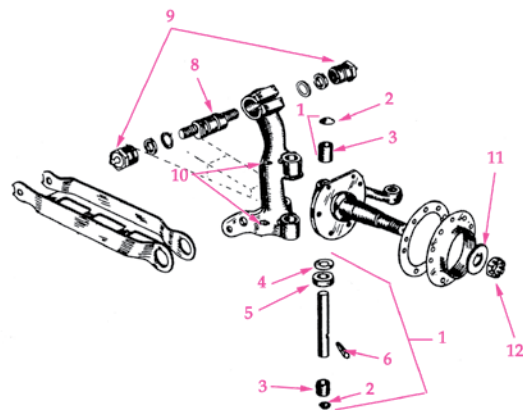
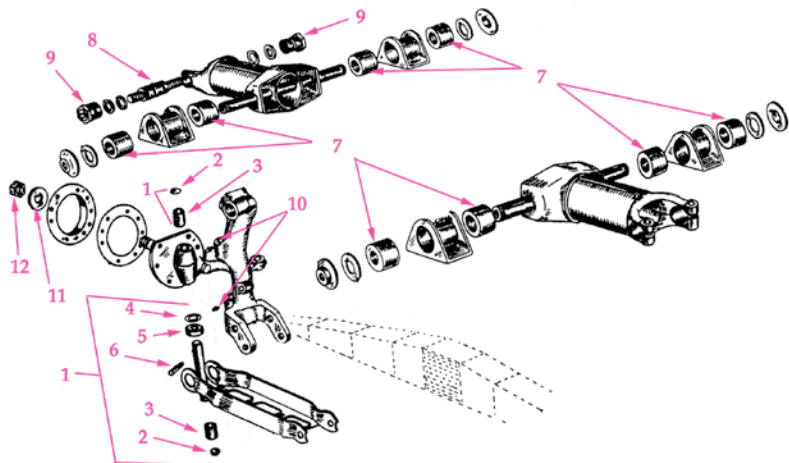

Driveshaft Center Support

### Front Axle & Steering

1934-37 Dictator & Coupe Express Models A, 1A, 3A, 5A & J-5

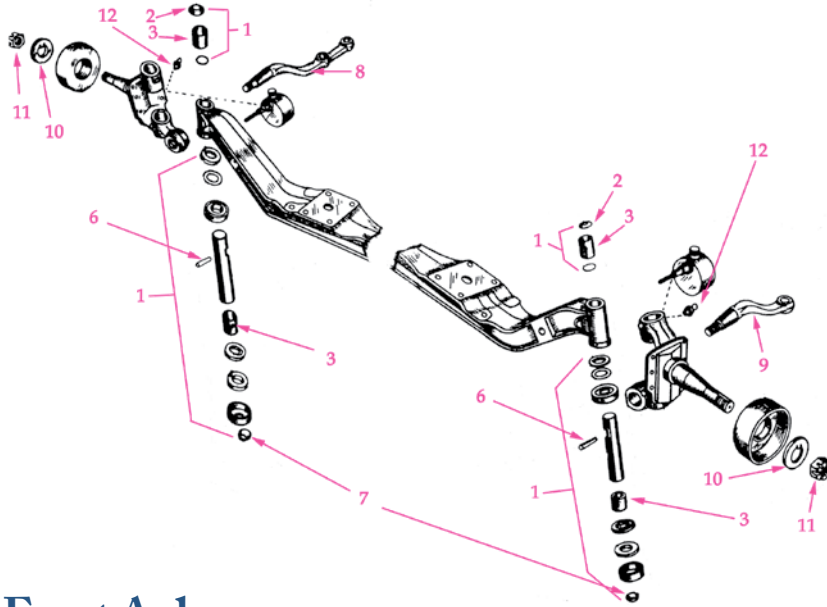

- (1) **S-335X1** Bushing & bearing kit. Less pins, gaskets, keys & most shims. Fits 1934-37 models A, 1A, 3A, 5A & J-5. .... **\$80.00 ea.**
- (2) **510144** Welch plug. Upper. Takes 2 ..... **\$1.65 ea.**
- (3) **510869** Bushing. Takes 4... **\$12.00 ea.**
- (4) **170513** Shim, (.053). .... **\$2.20 ea.**
- (5) **165010** Bearing. Takes 2. .... **\$17.50 ea.**
- (6) **510141** Key. Takes 2 ..... **\$6.50 ea.**
- (7) **510145** Welch plug, lower. Takes 2. .... **\$1.65 ea.**
- (8) **183080** Arm. Right side. Limited availability. Fits 1A, 3A, 5A & J-5.. **\$42.00 ea.**
- (9) **511126** Arm. Left side. Limited availability. Fits Model "A" ..... **\$42.00 ea.**
- (9) **511216** Arm. Left side. Limited availability. Fits 1A, 3A, 5A & J-5..... **\$42.00 ea.**
- (10) **130986** Washer. Takes 2.... **\$4.50 ea.**
- (11) **510292** Nut. Takes 2. .... **\$6.60 ea.**
- (12) **G443753** Grease fitting. Takes 2. .... **\$1.65 ea.**

### Front Axle 1949-61 1/2 ton and 3/4 ton truck

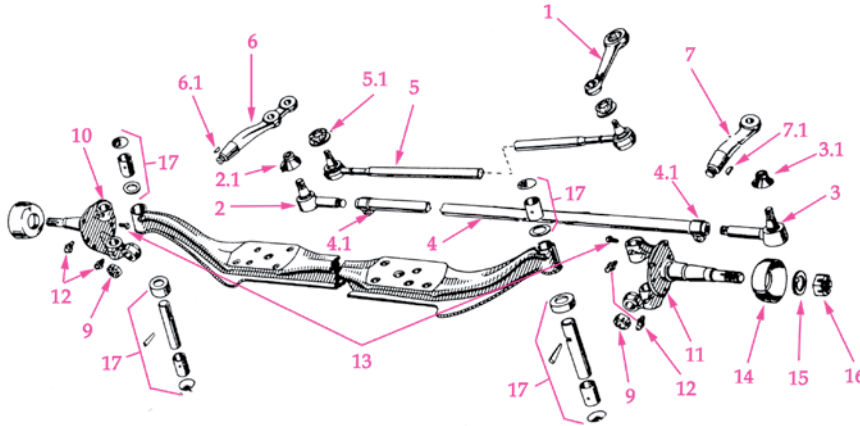

- (1) **676751** Arm. 2R5 & early 2R10 with T12 steering box..... **\$40.15 ea.**
- (1) **678670** Arm. 2R5 & late 2R10 with T12 steering box..... **\$40.15 ea.**
- (1) **679258** Arm. 2R5 & early 2R10, 3R 5, 10 & 11, 3E 1,5, & 10 all with TA12 steering box. .... **\$42.35 ea.**
- (1) **679614** Arm. 2R5 & late 2R10, 2R6, 2R11, 3R - 2E 6,7,11, & 12, 3E 2, 3,6,7,11 & 12, all with TA12 steering box. .... **\$71.50 ea.**
- (1) **680651** Arm. 2R5, 6, 10 & 11 with S-type steering gear..... **\$42.35 ea.**
- (1) **1692208** Arm. 5E & 6E all models. .... No Stock
- (2) **666193** Tie rod end. Right. 2R-6E all ..... **\$38.00 ea.**
- (3) **666194** Tie rod end. Left. 2R-6E all ..... **\$49.50 ea.**
- (2.1 & 3.1) **530202** Rubber boot, tie rod end. 2R-6E all..... **\$2.50 ea.**
- (4) **676692** Tie rod. Rod only. 2R5 - 2R10 (early) 48 3/4" long ..... **\$71.50 ea.**
- (4) **678666** Tie rod. Rod only. 2R5 - late 2R10. Also 3R-4E all models except 3E 10,11 & 12 with heavy duty axle. .... No Stock
- (4) **1692091** Tie rod. Rod only. 5E & 6E 5,6,7 ..... No Stock
- (4) **684147** Tie rod, rod only. 3E & 4E models 10,11,12 with heavy duty front axle. .... Call

- (4.1) **510487** Clamp. Tie rod. 2R-6E all models. Takes 2. .... **\$4.40 ea.**
- (5) **1689408** Reach rod or drag link. Includes ends. 2R-4E all models. .... **\$250.00 ea.**
- (5) **520111** End. Reach rod or drag link. Left hand thread. Has leather cover used on early version of drag link with removable ends. 2R-2E all models. Takes 2. .... **\$90.00 ea.**
- (5) **1689384** End. Reach rod or drag link. Right hand thread. 3E-6E all models. Takes 2. .... **\$42.60 ea.**
- (6) **676696** Arm. Right steering knuckle. 2R5 & early 2R10 . .... **\$91.30 ea.**
- (6) **678668** Arm. Right steering knuckle. 2R5 & late 2R10 and all 2R6, 2R11 and 2R12 trucks. Also 3R-4E all models except 4E 10,11,& 12 with heavy duty front axle. Used on 5E & 6E models 5,6,7. .... **\$82.50 ea.**
- (6) **684144** Arm. Right steering knuckle. 3E & 4E 10, 11,12 with heavy duty axle. Also 5E, 6E, 10,11,12 all ..... **\$95.50 ea.**
- (7) **677607** Arm. Left steering knuckle. 2R5 & early 2R10. .... No Stock
- (7) **678672** Arm. Left steering knuckle. 2R5 & late 2R10 and all 2R6, 2R11 and 2R12 trucks. Also 3R-4E all models except 4E 10,11, & 12 with heavy duty front axle. Used on 5E & 6E models 5,6,7. .... **\$82.50 ea.**

- (6) **684145** Arm. Left steering knuckle. 3E & 4E 10, 11,12 with heavy duty axle. Also 5E, 6E, 10,11,12 all ..... **\$94.60 ea.**
- (6.1 & 7.1) **G106751** Key. 2R-4E all models except 3E & 4E 10,11, and 12 with heavy duty front axle. Also used on 5E-6E 5,6,7 (Takes 2) ..... No Stock
- (6.1 & 7.1) **7X34** Feather key. 3E & 4E 10,11, 12 with heavy duty front axle & 5E and 6E 10,11,12 all..... No Stock
- (9) **510292** Nut, steering knuckle arm. 2R-4E all except 3E & 4E 10, 11,12 with heavy duty front axle also used on 5E & 6E 10,11,12 all ..... **\$6.60 ea.**
- (9) **684146** Nut, steering knuckle arm. 3E & 4E 10,11,12 with heavy duty front axle and all 5E & 6E 10,11,12..... **\$7.70 ea.**
- (10) **677604** Steering knuckle. Right. 2R-early 2E all models late 2 E- 6E all models 1-7 only. .... Call
- (10) **1685860** Steering knuckle. Right. Late 2E & all 3E and 4E 10,11,12 with standard front axle ..... **\$148.50 ea.**
- (10) **684134** Steering knuckle. Right. 3E & 4E 10,11,12 with heavy duty front axle.. **\$148.50 ea.**
- (11) **677605** Steering knuckle. Left. 2R-early 2E all models late 2 E- 6E all models 1-7 only.. Call
- (11) **1685861** Steering knuckle. Left. Late 2E & all 3E and 4E 10,11,12 with standard front axle. .... **\$148.50 ea.**
- (11) **684135** Steering knuckle. Left. 3E & 4E 10,11,12 with heavy duty front axle. **\$162.80 ea.**
- (12) Grease fitting. .... No Stock
- (13) **G102895** Set screw. 2R-4E all except 3E & 4E 10,11,12 with heavy duty front axle. Also used on 5E & 6E models 1-7. Takes 2. .... **\$1.10 ea.**
- (14) **191202** Oil slinger. 2R-6E models 1-7 (Takes 2) ..... **\$7.70 ea.**
- (15) **130986** Washer, with tang. 2R-2E all models except late 2E 10,11,12. Also used on 3E-6E 1,2,3,5,6,7. Takes 2 ..... **\$4.50 ea.**
- (16) **510292** Nut, front wheel bearing. 2R-6E all ..... **\$6.60 ea.**
- (17) **678171** King pin kit. 2R-6E all except 5E & 6E models 10,11,12. .... **\$74.00/kit**
- (17) **1692875** King pin kit. 5E & 6E models 10,11,12 ..... **\$239.00/kit**



## Front Axle Model M5

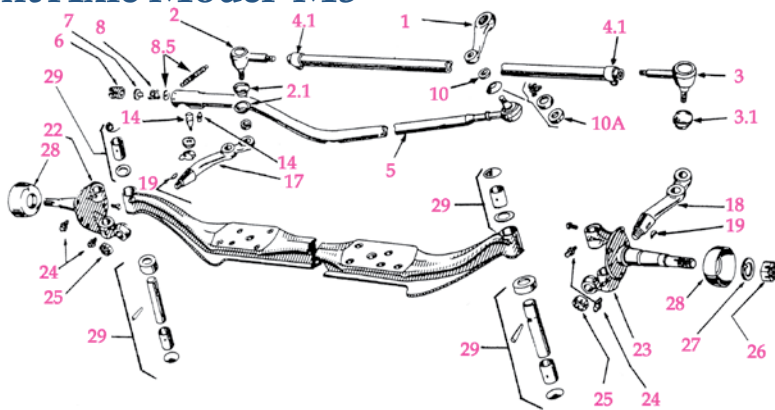

## Front Axle Model M15 Typical

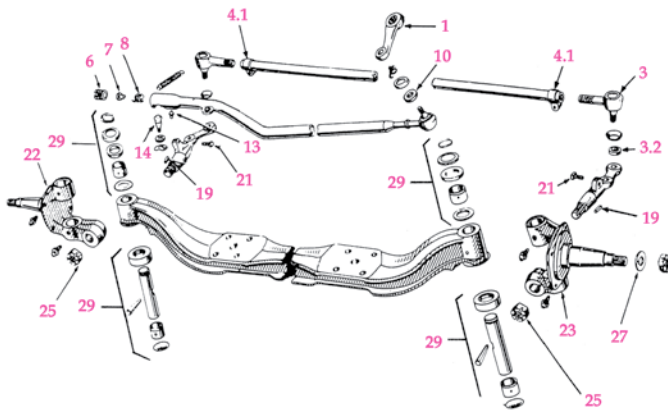

## Front Axle, Steering Knuckle & Linkage Models M16, M17

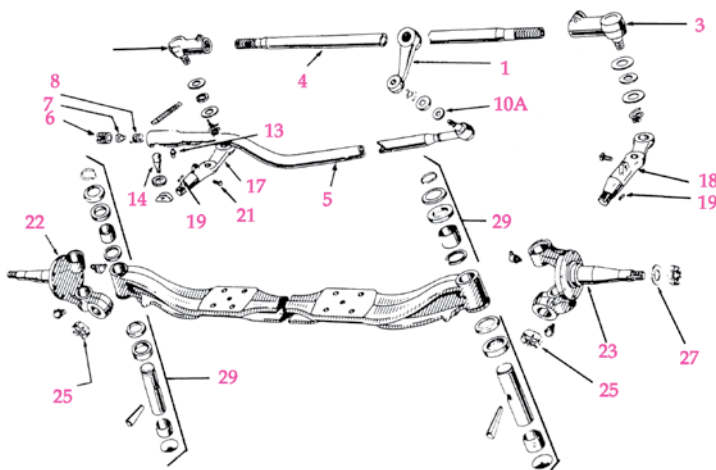

- (1) **665015** Pitman arm. M15, M15A, M16, M17 all models. .... **\$30.80 ea.**
- (1) **676413** Pitman arm. M5's on and after service #M5-3238. .... **\$38.50 ea.**
- (2) **664824** Tie rod end, right. M16 & M17 all. .... **\$45.00 ea.**
- (2) **666193** Tie rod end, right. M5 all. .... **\$38.00 ea.**
- (2) **666292** Tie rod end, right. M15 & M15A. all. .... **\$40.00 ea.**
- (3) **666007** Tie rod end, left. M16 & M17 all. .... **\$45.00 ea.**
- (3) **666194** Tie rod end, left. M5 all. .... **\$49.50 ea.**
- (2) **666293** Tie rod end, left. M15 & M15A all. .... **\$45.00 ea.**

- (2-3.1) **530202** Cover, tie rod end. Rubber. M5, M15, M15A all. .... **\$2.50 ea.**
- (4) **666006** Tie rod. Rod only. M16, M17 all. .... No Stock
- (4.1) **665309** Clamp. M5, M15, M15A all models. .... **\$5.50 ea.**
- (5) **666252** Drag link or reach rod. M5's prior to serial #M5-3238. .... **\$75.00 ea.**
- (5) **666822** Drag link or reach rod. M5's on and after serial #M5-3238. .... No Stock
- (6) **511252** Plug. All. .... Call
- (7) **511255** Seat, reach rod axle end. All. .... **\$3.63 ea.**
- (8) **511256** Spring, reach rod ball seat. M-Series. .... **\$5.50 ea.**

- (10A) **185048** Washer. M5 on and after service #M5-3238, M15, 15A, 16, 17 all. .... **\$3.30 ea.**
- (13) **G191758** Grease fitting. All. .... **\$3.30 ea.**
- (14) **631884** Ball stud. All models. .... Call
- (17) **665295** Arm, right. M5, all. .... **\$47.50 ea.**
- (17) **666013** Arm, right. M16 & M17 all. .... **\$94.60 ea.**
- (18) **665296** Arm, left. M5's all. .... Call
- (18) **666014** Arm, left. M16 & M17 all. .... **\$94.60 ea.**
- (19) **G124549** Key. All. Takes 2. .... **\$2.75 ea.**
- (19) **630836** Key. M15, 15A, 16, 17 all. Takes 2. .... **\$2.20 ea.**
- (20) **510292** Nut. M5 all. Takes 2. .... **\$6.60 ea.**
- (20) **630724** Nut. M15, M15A, M16, M17 all. Takes 2. .... **\$10.45 ea.**
- (21) **630845** Stop screw. M15, 15A, 16, 17. Takes 2. .... **\$7.70 ea.**
- (22) **665291** Knuckle & bushings, right. M5 original equipment casting #100368. .... **\$151.80 ea.**
- (22) **666009** Knuckle & bushings, right. M16 & M17 all. .... **\$154.00 ea.**
- (22) **666277** Knuckle & bushings, right. M15 prior to serial #M15-2001. .... Call
- (22) **673626** Knuckle & bushings, right. M15 after service #M15-2001 & M15A's prior to serial #M15A-14,482. .... **\$151.80 ea.**
- (22) **676553** Knuckle & bushings, right. M15A after serial #M15A-14,482. .... **\$181.50 ea.**
- (22) **677604** Knuckle & bushings, right. M5 replacement casting #102512. .... Call
- (23) **665292** Knuckle & bushings, left. M5 original equipment, casting #100368. .... Call
- (23) **666010** Knuckle & bushings, left. M16 & M17 all. .... **\$154.00 ea.**
- (23) **673627** Knuckle & bushings, left. M15's after serial #M15-2001 & M15A's prior to serial #M15A-14,482. .... **\$151.80 ea.**
- (23) **676278** Knuckle & bushings, left. M15's prior to serial #M15-2001. .... No Stock
- (23) **676554** Knuckle & bushings, left. M15A's after serial #M15A-14,482. .... **\$181.50 ea.**
- (23) **677605** Knuckle & bushings, left. M5 replacement, casting #102512. .... Call
- (24) **634049** Grease fitting. M15, 15A, 16, 17. Takes 4. .... No Stock
- (25) **510292** Nut. M5 all. Takes 2. .... **\$6.60 ea.**
- (25) **630724** Nut. M15, 15A, 16, 17 all. Takes 2. .... **\$10.45 ea.**
- (26) **510292** Nut. M5 all. Takes 2. .... **\$6.60 ea.**
- (27) **130986** Lock washer. All. Takes 2. .... **\$4.50 ea.**
- (28) **191202** Oil slinger. M5 all. Takes 2. .... **\$7.70 ea.**
- (29) **674533X1** King pin kit, bushings and bearings only. M5's with steering knuckles having forging #100368. .... **\$45.00 ea.**
- (29) **674534** King pin kit. M15's and early M15A's. .... **\$68.00 ea.**
- (29) **674535** King pin kit. M16 & M17 all. .... **\$90.50 ea.**
- (29) **676587** King pin kit. M15A's after serial #M15A-14,482. .... **\$95.00 ea.**
- (29) **678171** King pin kit. M5's with replacement steering knuckles having forging #102512. .... **\$74.00 ea.**

# Front Axle - Steering Knuckle, Control Arms, & King Pins

Model 9A before car serials: South Bend - 4,112,701 & Los Angeles - 4,803,802 1938 All Cars & early 1939 Commander - 9A

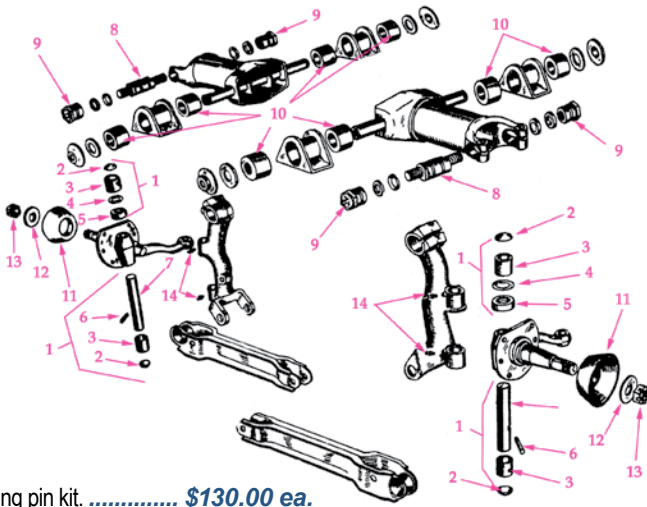

- (1) **S-333** King pin kit. .... **\$130.00 ea.**
- (1) **S-333X1** Bushing & bearing set only. Less pins, keys, shims, & welch plugs. .... **\$80.00 ea.**
- (2) **127047** Welch plug. .... Available in S-333 kit only.

- (3) **510869** Bushing. Takes 4. .... **\$12.00 ea.**
- (4) **181647** Shim. Available in S-333 kit only.
- (5) **165010** Thrust bearing. All. Takes 2. .... **\$17.50 ea.**
- (6) **510141** Key. Also available in king pin kit. Takes 2. .... **\$6.50 ea.**
- (7) **191135-6** King pins. .... Order S-333 Complete king pin kit
- (8) **191679** Pin. All. Takes 2. .... **\$32.00 ea.**
- (9) **185792** Bushing. All. Takes 4. .... **\$24.00 ea.**
- (10) **182920** Bushing. All. Takes 8. .... **\$6.00 ea.**
- (11) **191202** Slinger. All. Takes 2. .... **\$7.70 ea.**
- (12) **130986** Washer. All. Takes 2. .... **\$4.50 ea.**
- (13) **510292** Nut. All. Takes 2. .... **\$6.60 ea.**
- (14) **G443753** Grease fitting. All. Takes 4. .... **\$1.65 ea.**

## Front Axle Steering 1962 (7E) truck and 7E & 8E (1962-64) Models 13,15,25,35,40,45

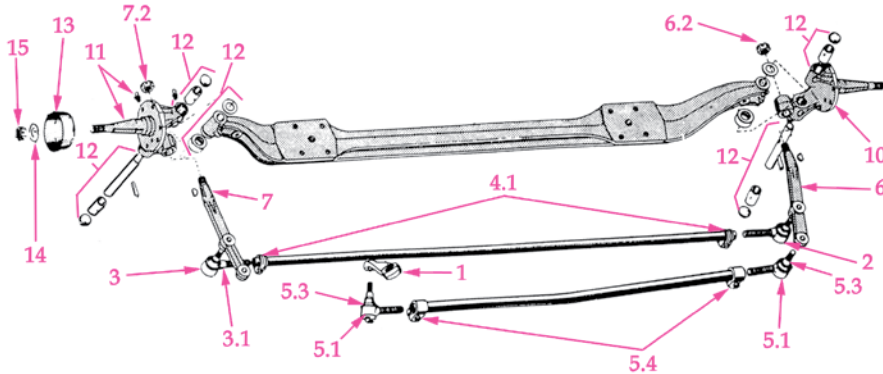

- (1) **679274** Pitman arm. 7E 13 **\$52.80 ea.**
- (1) **679276** Pitman arm. 7E & 8E 25, 28, 35, 40, 45. .... Call
- (1) **1692208** Pitman arm. 7E 5, 7, 10, 12. .... No Stock
- (1) **1696518** Pitman arm. 8E 13,15. .... **\$52.80 ea.**
- (2) **684163** Tie rod end, right. 7E & 8E, 25, 28, 35, 40, 45. .... **\$55.00 ea.**
- (2) **666193** Tie rod end, right. 7E 5, 7 and 7E & 8E, 10,12,13,15. .... **\$38.00 ea.**
- (2) **684164** Tie rod end, left. 7E & 8E,25,28,35,40,45. .... **\$55.00 ea.**
- (2) **666194** Tie rod end, left. 7E 5, 7 and 7E & 8E, 10,12,13,15. .... **\$49.50 ea.**
- (2.1-3.1) **530202** Tie rod rubber boot. 7E 5 & 7 all, 7E-8E 10,12,13,15. Takes 2. .... **\$2.50 ea.**
- (4) **684159** Tie rod. Rod only. 7E-8E 25, 28, 35, also 40 & 45 with standard front axle. .... **\$82.50 ea.**
- (4) **1692580** Tie rod. Rod only. 7E 10 & 12. .... **\$52.80 ea.**
- (4.1) **510487** Clamp. 7E-8E 5, 7, 10, 11, 13,15. Takes 2. .... **\$4.40 ea.**
- (4.1) **684162** Clamp. 7E-8E 25-45. Takes 2. .... **\$7.70 ea.**
- (5.1) **1689384** Reach rod ends. 7E 5-15. Takes 2 on early 7E 5, 7,10,12,13,15 and takes only 1 on late 2E 5,7,10,12. .... **\$42.60 ea.**
- (5.1) **1689389** Reach rod ends. 7E & 8E 25-45. Takes 2. .... **\$82.50 ea.**
- (5.3) **530202** Reach rod end seal. 7E 5-15. Takes 2. .... **\$2.50 ea.**
- (5.4) **1688227** Clamp, reach rod end. Early 7E 5,7,10,12. Also 7E-8E 13 & 15. Takes 2. .... **\$14.75 ea.**
- (5.4) **1695664** Reach rod end clamp. Late 7E 5, 7, 10, 12. Takes 2. .... **\$7.70 ea.**
- (6) **678668** Steering arm, right. 7E 5 & 7E 7. .... **\$82.50 ea.**
- (6) **684144** Steering arm, right. 7E 10 & 12, 7E-8E 13 & 15. .... **\$95.50 ea.**
- (6) **684160** Steering arm, right. 7E-8E 25, 28, 35. .... **\$95.50 ea.**
- (6) **1688088** Steering arm, right. 7E-8E 40 & 45 with standard front axle. .... **\$44.60 ea.**
- (6) **1691100** Steering arm, right. 7E-8E 40 & 45 with heavy duty axle. .... **\$115.50 ea.**
- (7) **678669** Steering arm, left. 7E 5 & 7E 7. .... **\$82.50 ea.**
- (7) **684145** Steering arm, left. 7E 10 & 12, 7E-8E 13 & 15. .... **\$94.60 ea.**
- (7) **684161** Steering arm, right. 7E-8E 25, 28, 35. .... **\$94.60 ea.**
- (7) **1688089** Steering arm, left. 7E-8E 40 & 45 with standard front axle. .... **\$93.50 ea.**
- (7) **1691101** Steering arm, left. 7E-8E 40 & 45 with heavy duty axle. .... **\$115.50 ea.**
- (6.2-7.2) **684146** Nut, arm hex. 7E-8E all except 5 & 7. .... **\$7.70 ea.**
- (6.2-7.2) **1543223** Nut, arm hex. 7E 5 & 7. .... **\$6.00 ea.**
- (10) **684134** Steering knuckle, right. 7E-8E 13 & 15. .... **\$148.50 ea.**

- (10) **684150** Steering knuckle, right. 7E-8E 25, 28, 35. .... **\$176.00 ea.**
- (10) **1688084** Steering knuckle, right. 7E-8E 40 & 45 with standard front axle. .... **\$242.00 ea.**
- (10) **1692592** Steering knuckle, right. 7E 10 & 11. .... **\$225.50 ea.**
- (11) **684135** Steering knuckle, left. 7E-8E 13 & 15. .... **\$162.80 ea.**
- (10) **684151** Steering knuckle, left. 7E-8E 25,28,35. .... **\$176.00 ea.**
- (10) **1691099** Steering knuckle, left. 7E-8E 40 & 45 with heavy duty front axle. .... **\$357.50 ea.**
- (11) **1692593** Steering knuckle, left. 7E 11 & 12. .... **\$225.50 ea.**
- (11) **1694611** Steering knuckle, left. 7E-8E 40 & 45 with air brakes. .... **\$302.50 ea.**
- (12) **678171** King pin kit. 7E 5 & 7. .... **\$74.00 ea.**
- (12) **684492** King pin kit. 7E-8E 13 & 15. .... **\$94.60 ea.**
- (12) **684493** King pin kit. 7E-8E 25, 28, 35. .... **\$110.00 ea.**
- (12) **1689073** King pin kit. 7E-8E 40 & 45 with standard front axle. .... **\$93.50 ea.**
- (12) **1691096** King pin kit. 7E-8E 40 & 45 with heavy duty front axle. .... Call
- (12) **1692875** King pin kit. 7E 10 & 11. .... **\$239.00 kit**
- (13) **191202** Oil slinger. 7E 5 & 7. Takes 2. .... **\$7.70 ea.**
- (14) **1539026** Lock washer. 7E-8E 5-35. .... **\$2.20 ea.**
- (14) **1686179** Lock washer. 7E-8E 40 & 45 with standard front axle and less air brakes. .... **\$7.70 ea.**
- (14) **1691112** Lock washer. 7E-8E 40 & 45 with heavy duty front axle. .... **\$10.45 ea.**
- (15) **1543223** Nut, front wheel bearing. All 7E-8E 5 through 35 having forging # embossed on front axle. .... **\$6.00 ea.**
- (15) **1686180** Nut, front wheel bearing. 7E-8E 40 & 85 having forging # embossed on front axle. With standard axle & without air brakes. .... **\$7.70 ea.**
- (15) **1691111** Nut, front wheel bearing. All 7E-8E 40 & 45 having axle ID embossed on axle and having a heavy duty front axle. .... **\$9.50 ea.**



# Front Axle Series 2R-6E Models 13,14,15

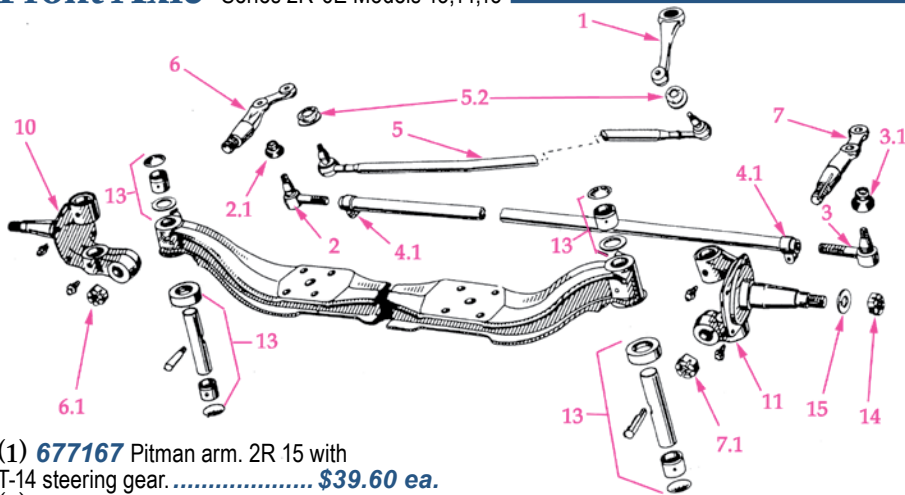

- (1) **677167** Pitman arm. 2R 15 with T-14 steering gear. .... **\$39.60 ea.**
- (1) **679274** Pitman arm. 2R-6E models 13,14,15. .... **\$52.80 ea.**
- (2) **666193** Tie rod end, right. E - 6E 13,14,15. .... **\$38.00 ea.**
- (2) **666292** Tie rod end, right. 2R-3R 14 & 15 all. .... **\$40.00 ea.**
- (3) **666194** Tie rod end, left. E - 6E 13,14,15. .... **\$49.50 ea.**
- (3) **666293** Tie rod end, left. 2R-3R 14 & 15 all. .... **\$45.00 ea.**
- (2.1-3.1) **530202** Tie rod end rubber seal. All. .... **\$2.50 ea.**
- (4) **510487** Clamp. E-6E all. .... **\$4.40 ea.**

- (4) **1688227** Clamp. 2R-3R 14 & 15 all. .... **\$14.75 ea.**
- (5) **1689408** Reach rod or drag link. Actually for the 1/2 ton & 3/4 ton but should work on these models also. .... **\$250.00 ea.**
- (5.1) **520111** Drag link end. Left hand thread attaches to early version of drag link with replaceable ends 2R-6E all. Takes 2. .... **\$90.00 ea.**
- (5.1) **1689384** Drag link end. Right hand thread attaches to later style rod with replaceable ends 2R-6E all. Takes 2. .... **\$42.60 ea.**
- (5.2) **530202** Drag link end rubber seal. 2R-6E all. Takes 2. .... **\$2.50 ea.**

- (6) **677162** Steering knuckle arm, right. 2R-3R 14 & 15. .... **\$105.60 ea.**
- (6) **684144** Steering knuckle arm, right E-6E 13,14,15. .... **\$95.50 ea.**
- (7) **677163** Steering knuckle arm, left. 2R-3R 14 & 15. .... Call
- (6) **684145** Steering knuckle arm, left. E - 6E 13,14,15. .... **\$94.60 ea.**
- (6.1-7.1) **630724** Nut, arm hex. 2R-3R 14 & 15. .... **\$10.45 ea.**
- (6.1-7.1) **684146** Nut, arm hex. E - 6E 13,14,15. .... **\$7.70 ea.**
- (10) **676553** Knuckle, right steering. 2R - 3R 14 & 15. .... **\$181.50 ea.**
- (10) **684144** Knuckle, right steering. E - 6E 13,14,15. .... **\$95.50 ea.**
- (11) **676554** Knuckle, left steering. 2R - 3R 14 & 15. .... **\$181.50 ea.**
- (11) **684135** Knuckle, left steering. E - 6E 13,14,15. .... **\$162.80 ea.**
- (13) **676587** King pin kit. 2R & 3R 14,15. .... **\$95.00 ea.**
- (13) **684492** King pin kit. E & 6E 13,14,15. .... **\$94.60 ea.**
- (14) **510292** Nut, front wheel bearing. E & 6E 13,14,15. .... **\$6.60 ea.**
- (14) **165391** Nut. 2R & 3R 14,15. Also all E-series and some 2E trucks. .... **\$4.50 ea.**
- (14) **130986** Nut, front wheel bearing. 2R & 3R 14,15. .... **\$4.50 ea.**
- (15) **1539026** Lock washer. Some 2E series trucks and all 3E-6E. .... **\$2.20 ea.**

# Front Axle Steering Knuckle & Linkage

Model 8E 1963-64 1/2 ton & 3/4 ton truck

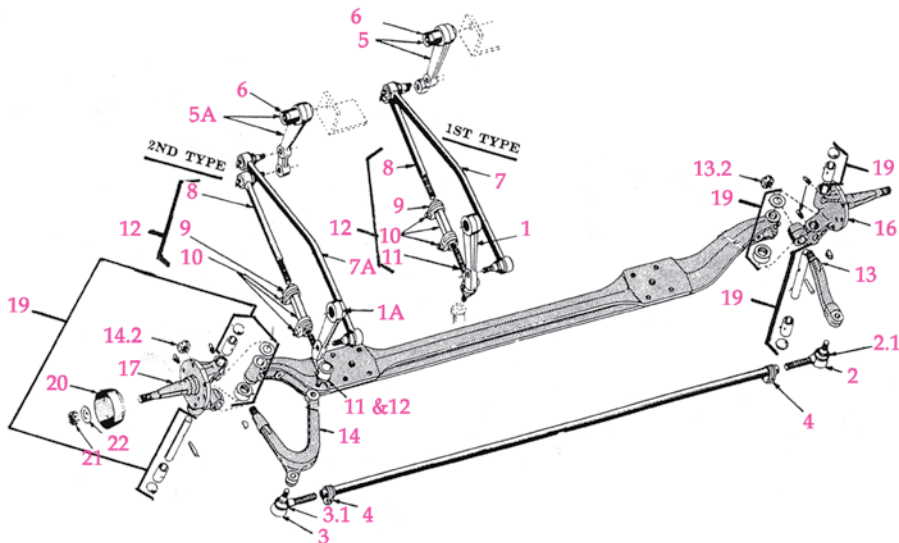

- (1) **1696293** Pitman arm. 8E 10 & 12 prior to serial # E10-39,945 and E12-5,988. **\$41.80 ea.**
- (1) **1696295** Pitman arm. 8E 5 & 7 prior to serial #E5-136,610 and E7-19,245. ... No Stock
- (1A) **1696293** Pitman arm. 8E 10 & 12 after serial #E10-39,945 and #E12-5,988, also 8E 5 & 7 after serial #E5-136,610 and E7-19,245. .... **\$41.80 ea.**
- (2) **1696862** Tie rod end, right. **\$71.50 ea.**
- (3) **1696863** Tie rod end, left. **\$71.50 ea.**
- (2.1-3.1) **530202** Rubber seal for tie rod end. Takes 2. .... **\$2.50 ea.**

- (4) **510487** Clamp. 8E all. .... **\$4.40 ea.**
- (5) **1696278** Idler lever with bushing. Early 8E 5,7,10,12. See Pitman arm for relevant serial numbers. .... **\$69.10 ea.**
- (6) **1696946** Bushing. 8E all. ... **\$15.00 ea.**
- (7) Rod with ends. 1st type. .... Call
- (7A) **1697201** Rod with ends. 2 type. See Pitman arm for relevant serial numbers. .... **\$115.50 ea.**
- (8) **1697037** Reach rod end. Long. .... **\$66.00 ea.**
- (9) **1695664** Clamp. 8E all. .... **\$7.70 ea.**

- (10) **1695663** Rod with clamps. 8E all. .... **\$31.30 ea.**
- (11) **1697036** Reach rod end. Short. 8E all. .... Order complete assembly
- (12) **1696563** Reach rod assembly. Includes both ends, rod, and 2 clamps. 8E all. .... **\$99.00 ea.**
- (13) **1696606** Steering knuckle arm, right. 8E 5 & 7 all. .... **\$115.50 ea.**
- (13) **1696610** Steering knuckle arm, right. 8E 10 & 12 all. .... **\$126.50 ea.**
- (13.2) **684146** Nut, arm hex. 8E 10 & 12 all. Takes 2. .... **\$7.70 ea.**
- (13.2) **1543223** Nut, arm hex. 8E 5 & 7 all. Takes 2. .... **\$6.00 ea.**
- (14) **1696607** Steering knuckle arm, left. 8E 5 & 7 all. .... **\$115.50 ea.**
- (14) **1696611** Steering knuckle arm, left. 8E 10 & 12 all. .... **\$225.50 ea.**
- (16) **1692592** Steering knuckle, right. 8E 10 & 12. .... **\$225.50 ea.**
- (17) **1692593** Steering knuckle, left. 8E 10 & 12. .... **\$225.50 ea.**
- (19) **678171** King pin kit. 8E 5 & 7 all. .... **\$74.00 kit**
- (19) **1692875** King pin kit. 8E 10 & 12 all. .... **\$239.00 kit**
- (20) **191202** Oil slinger. 8E 5 & 7. .... **\$7.70 ea.**
- (21) **1539026** Washer. 8E all. ... **\$2.20 ea.**
- (22) **1543223** Nut. 8E all. .... **\$6.00 ea.**

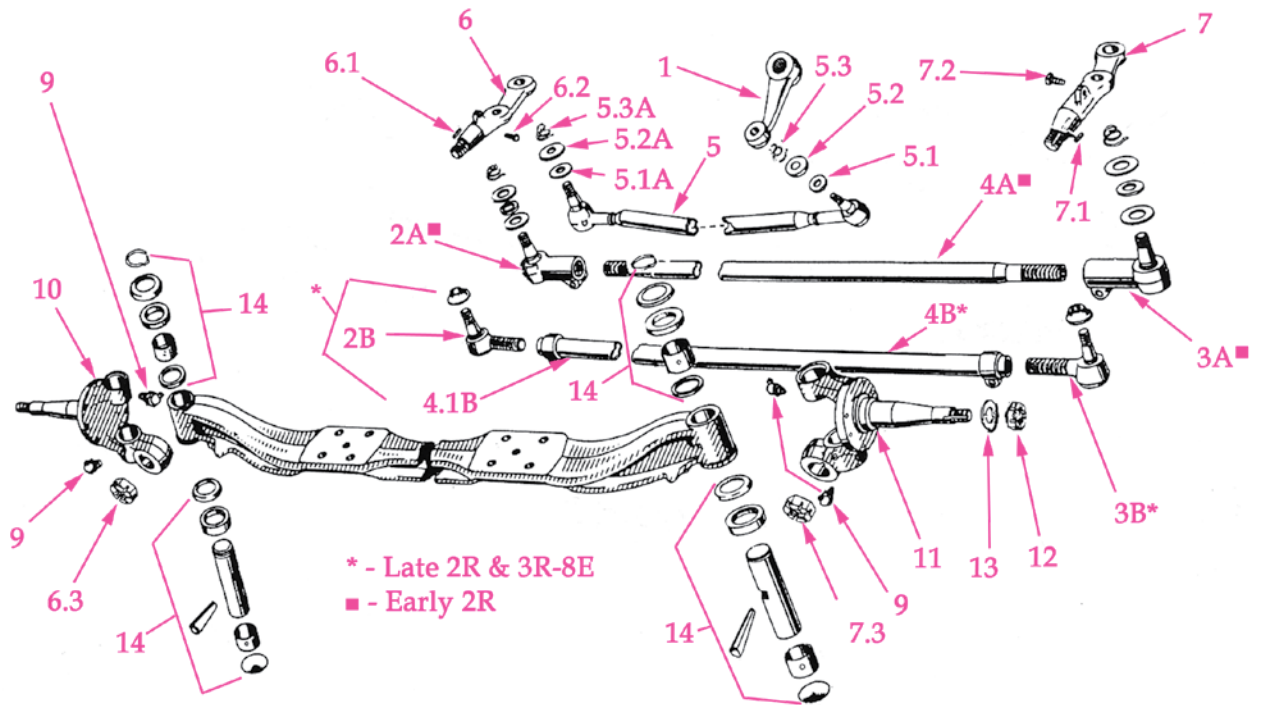

- (1) **676841** Pitman arm. Early 2R 16 & 17 with T-14 steering gear. .... **\$41.80 ea.**
- (1) **679276** Pitman arm. Late 2R 16 & 17 and all 3R-6E trucks models 16-40. .... Call
- (2A) **664824** Tie rod end, right. Early 2R 16 & 17. .... **\$45.00 ea.**
- (2B) **678592** Tie rod end, right. Late 2R 16 & 17 and 2R-5E 28 & 38. .... **\$55.00 ea.**
- (2B) **684163** Tie rod end, right. 2E 28 & 38-6E 16, 17, 28, 38, 40. .... **\$55.00 ea.**
- (3A) **666007** Tie rod end, left. Early 2R 16 & 17. .... **\$45.00 ea.**
- (3B) **678593** Tie rod end, left. Late 2R 16 & 17 and 2R-5E 28, 38. .... **\$55.00 ea.**
- (3B) **684164** Tie rod end, left. 2E 28 & 38-6E 16, 17, 28, 38, 40. .... **\$55.00 ea.**
- (4A) Rod. Early 2R 16 & 17. .... No Stock
- (4B) **678594** Rod only. Late 2R 16 & 17 and all 3R-Series, E-series having front axle with forging #3100-Y-623. .... **\$94.60 ea.**
- (4B) **684159** Rod only. E-series truck with front axle having forging #106479 1A & 2E all -6E. .... **\$82.50 ea.**
- (4.1) **684162** Clamp. Late 2R and all 3R-6E trucks. .... **\$7.70 ea.**
- (5) Drag link assembly. .... Call
- (5.1) **681512** Drag link ends. 2R 16-2E 28 & 38 all. .... **\$52.00 ea.**
- (5.1) **1689389** Drag link ends. 3E-6E 16-40. .... **\$82.50 ea.**
- (6) **684160** Steering knuckle arm, right. E-series trucks having forging #1064791A and 2E-6E all except model 40. .... **\$95.50 ea.**
- (6) **684775** Steering knuckle arm, right. 2R-3R all & E-series having forging #1064711 on front axle. .... No Stock

- (6) **1688088** Steering knuckle arm, right. 3E-6E 40 with standard front axle. ... **\$44.60 ea.**
- (6) **1691100** Steering knuckle arm, right. 4E-6E 40 with heavy duty front axle. **\$115.50 ea.**
- (7) **684161** Steering knuckle arm, left. E series trucks having forging #1064791A and 2E-6E all except model 40. .... **\$94.60 ea.**
- (7) **684776** Steering knuckle arm, left. 2R-3R all & E-series having forging #1064711 on front axle. .... No Stock
- (7) **1688089** Steering knuckle arm, left. 3E-6E 40 with standard front axle. ... **\$93.50 ea.**
- (7) **1691101** Steering knuckle arm, left. 4E-6E 40 with heavy duty front axle. **\$115.50 ea.**
- (6.1- 7.1) **630836** Woodruff key. 2R & 3R all & early E-series having a front axle with forging #3100-Y-623 ..... **\$2.20 ea.**
- (6.3-7.3) **630724** Hex nut. 2R & 3R all and early E-series having a front axle with forging #3100-Y-623. .... **\$10.45 ea.**
- (6.3-7.3) **630724** Hex nut. 3E-6E all. .... **\$10.45 ea.**
- (9) **G109350** Grease fitting. 2R-3R all & E-series with front axle having casting #3100-Y-623. .... **\$1.95 ea.**
- (9) **G191758** Grease fitting. E-series with front axle having casting #106479AA A & all 2E's. .... **\$3.30 ea.**
- (10) **666609** Steering knuckle, right. 2R-E-series models 16, 17, 28, 38. .... **\$154.00 ea.**
- (10) **684150** Steering knuckle, right. 3E-6E 16, 17, 28, 38. .... **\$176.00 ea.**
- (10) **1688084** Steering knuckle, right. 3E-6E model 40 with standard front axle. **\$242.00 ea.**
- (10) **1691098** Steering knuckle, right. 4E-6E model 40 with heavy duty front axle. .... Call

- (11) **666010** Steering knuckle, left. 2R-E-series models 16, 17, 28, 38. .... **\$154.00 ea.**
- (11) **684151** Steering knuckle, left. 3E-6E 16, 17, 28, 38. .... **\$176.00 ea.**
- (11) **1688085** Steering knuckle, left. 3E-6E model 40 with standard front axle. .... No Stock
- (11) **1691099** Steering knuckle, left. 4E-6E model 40 with heavy duty front axle. .... **\$357.50 ea.**
- (12) **510292** Nut, wheel bearing lock E & 2E series all and 3E-6E models 16-38. .... **\$6.60 ea.**
- (12) **1686180** Nut, wheel bearing lock. 3E-6E 40 with standard axle. .... **\$7.70 ea.**
- (13) **130986** Lock washer. 2R-E and some 2E models. .... **\$4.50 ea.**
- (13) **1539026** Lock washer. Late 2E-series. .... **\$2.20 ea.**
- (13) **1686179** Lock washer. 3E-6E 40 with standard front axle. .... **\$7.70 ea.**
- (13) **1691112** Lock washer. 4E-6E 40 with heavy duty front axle. .... **\$10.45 ea.**
- (14) **674535** King pin kit. 2R-3R all and E-series having a front axle with forging #3100-Y-623. .... **\$90.50 ea.**
- (14) **684493** King pin kit. E-series having a front axle with forging #106471A & all 2E-6E models 16-38. .... **\$110.00 ea.**
- (14) **1689073** King pin kit. 3E-6E 40 with standard front axle. .... **\$93.50 ea.**
- (14) **1691096** King pin kit. 4E-6E 40 with heavy duty front axle. .... Call



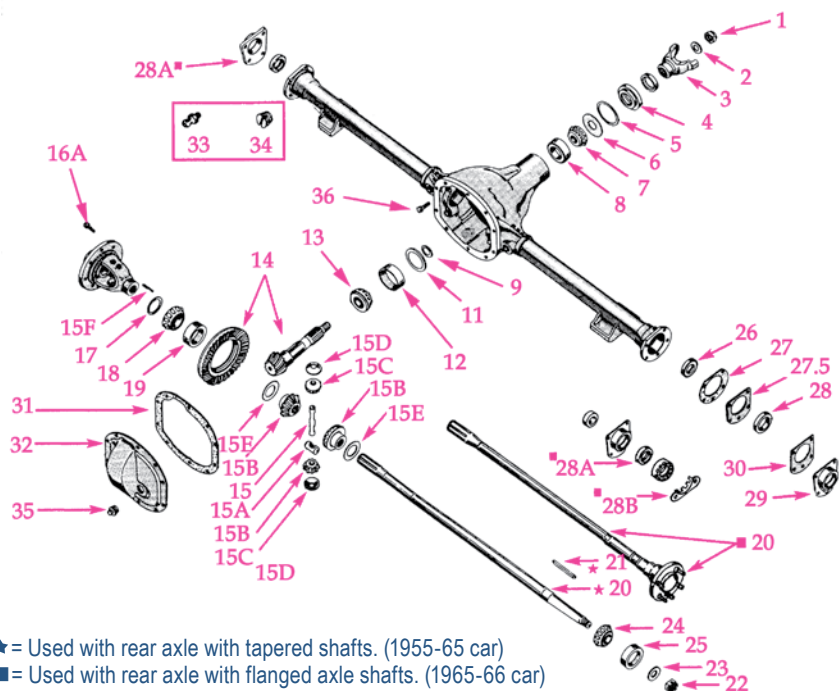

★ = Used with rear axle with tapered shafts. (1955-65 car)  
 ■ = Used with rear axle with flanged axle shafts. (1965-66 car)

- (1) **527432** Nut. 1955-66 all models.  
Used. .... **\$11.00 ea.**
- (2) **196965** Washer. 1955-56 all models.  
..... **\$4.40 ea.**
- (3) **521825** Flange. 1955-60 with #23 rear axle. .... **\$71.50 ea.**
- (3) **1549708** Flange. 1960-66 with #27 rear axle. .... **\$88.00 ea.**
- (4 & 5) **199379X1** & **184161** Pinion seal. 1955-66 all models. .... **\$16.00/set**
- (6) **537678** Slinger. 1956-66 all models.  
..... **\$16.75 ea.**
- (7) **190033** Cone & rollers. 1955-60 with #23 rear axle. .... **\$40.50 ea.**
- (7) **1549626** Cone & rollers. 1960-66 with #27 rear axle. .... **\$48.00 ea.**
- (8) **190032** Cup. 1955-60 with #23 rear axle  
..... **\$17.50 ea.**
- (8) **1549625** Cup. 1960-66 with #27 rear axle.  
..... **\$11.00 ea.**
- (9) **190038-41** Shims .003, .005, .010, .030 with #23 rear axle. .... **\$2.90 ea.**
- (9) **1549630-33** Shims .003, .005, .010, .030. 1960-66 with #27 rear axle.... **\$2.20 ea.**
- (11) **511652-54** Shims .003, .005, .010. 1955-60 with #23 rear axle. .... **\$2.90 ea.**
- (11) **1549634-36** Shims .003, .005, .010. 1960-66 with #27 rear axle. .... **\$2.20 ea.**
- (12) **190035** Cup. 1955-60 with #23 rear axle. .... **\$18.65 ea.**
- (12) **1549627** Cup. 1960-66 with #27 rear axle. .... **\$15.00 ea.**
- (13) **190036** Cone & rollers. 1955-60 all with #23 rear axle. .... **\$51.00 ea.**
- (13) **1549628** Cone & rollers. 1960-66 with #27 rear axle. .... **\$38.50 ea.**
- (14) Ring & Pinion. .... Call (15-15F) **520188** Side bevel gear kit. 1955-60 with #23 rear axle. Used. .... **\$154.00 ea.**
- (15-15F) **1550291** Side bevel gear kit. 1960-65 with #27 tapered axles. **\$121.00 ea.**
- (15) **194835** Shaft. 1955-66 all models.  
..... **\$16.50 ea.**

- (15A) **194854** Thrust block. 1955-65 all with tapered axles. Only available in 520188 kit.
- (15A) **1562419** Thrust block. For flanged rear axles. .... **\$18.40 ea.**
- (15B) **194834** Gear, side bevel. 1955-60 with #23 rear axle. .... Order 520188 kit
- (15C) **194833** Gear, pinion. 1955-60 with #23 rear axle. .... Order 520188 kit
- (15D) **194836** Thrust washer. 1955-60 with #23 rear axle. Takes 2. .... **\$7.70 ea.**
- (15E) **194838** Thrust washer. 1955-60 with #23 rear axle. Takes 2. .... **\$7.70 ea.**
- (15F) **510722** Pin. 1955-60 with #23 rear axle. .... **\$2.90 ea.**
- (15F) **1685564** Pin. 1960-66 with #27 rear axle. .... **\$4.40 ea.**
- (16) **196313** Case. 1955-59 all with 4:10, 4:27, 4:56 & 4:88 gear ratio. .... **\$132.00 ea.**
- (16) **529399** Case. 1955-60 with #23 rear axle having 3:54 gear ratio. .... **\$115.50 ea.**
- (16) **1549638** Case. 1960-66 with #27 rear axle having 3:07, 3:31, 3:54 or 3:73 gear ratio. .... **\$115.50 ea.**
- (16) **1549639** Case. 1960-66 with #27 rear axle having 4:10, 4:27 or 4:56 gear ratio. .... **\$115.50 ea.**
- (16A) **527171** Screw. 1955-58 all models and 1960-66 with #27 rear axle. Takes 8. .... **\$5.50 ea.**
- (16A) **1548650** Screw. 1959-60 with #23 rear axle. Takes 8. .... **\$4.40 ea.**
- (17) **1549648-51** Shim. .003, .005, .010, .030. 1955-66 all models. .... **\$2.20 ea.**
- (18) **196287** Cone & rollers. 1955-60 with #23 rear axle. Takes 2. .... **\$49.75 ea.**
- (18) **1690219** Cone & rollers. 1960-66 with #27 rear axle. Takes 2. .... **\$25.25 ea.**
- (19) **196286** Cup. 1955-60 with #23 rear axle. Takes 2. .... **\$51.00 ea.**

- (19) **1549645** Cup. 1960-66 with #27 rear axle. .... **\$36.90 ea.**
- (20) **1560422** Axle shaft. 1955-60 with #23 rear axle. Takes 2. .... **\$93.50 ea.**
- (20) **1559059** Axle shaft. 1960-62 with #27 rear axle. Takes 2. .... **\$126.50 ea.**
- (20) **1560426** Axle shaft. 1963-65 with #27 rear axle having tapered axles... **\$159.50 ea.**
- (20) **1562424** Axle shaft. 1965-66 with #27 or 44 rear axle having flanged axles. .... **\$93.50 ea.**

**Note for 1562424:** For shaft axle assembly - including axle shaft, bearing, bearing retainer & seal - order right side 1562422 and Left side 1562423.

- 1562422** Right..... **\$250.00 ea.**
- 1562423** Left..... **\$250.00 ea.**

- (21) **194841** Key. 1955-65 all with tapered axles. Takes 2. .... **\$5.00 ea.**
- (22) **510516** Nut. 1955-65 all models with tapered axles. Takes 2. .... **\$10.65 ea.**
- (23) **510518** Washer. 1955-65 all models with tapered axles. Used. Takes 2. **\$5.00 ea.**
- (24) **530451** Cone & rollers. 1955-65 all with tapered axles. Takes 2. .... **\$40.55 ea.**
- (24) **1562421** Cone & rollers. 1965-66 all models with "flanged" axles. .... **\$41.50 ea.**
- (25) **165167** Cup. 1955-66 all models. Takes 2. .... **\$13.00 ea.**
- (26) **530573** Seal, "inner". 1955-66 all models. Takes 2. .... **\$18.00 ea.**
- (27) **194844-6** Shims .005, .010, .030. All 1955-66 with tapered axles. .... **\$4.25 ea.**
- (27.5) **519383** Plate, reinforcement. 1955-66 all models. Takes 2. Used. .... **\$7.00 ea.**
- (28) **197216** Washer, felt. Outer. 1955-65 all models with tapered axles. .... **\$2.75 ea.**
- (28A) **1562434** Seal, outer. 1965-66 having flanged axles. .... Call (28 B) **1563292** Plate, ring lock. 1965-66 having flanged axles. .... **\$4.40 ea.**
- (29) **533161** Washer & retainer. 1955-65 all models with tapered axles. Comes with (1) 197436 gasket. .... **\$20.00 ea.**
- (30) **197436** Gasket. 1955-65 all models with tapered axles. Takes 4. .... **\$1.50 ea.**
- (30) **1562390** Gasket. 1965-66 all models with flanged axles. .... **\$1.10 ea.**
- (31) **1560245** Gasket. 1955-66 all models. .... **\$10.00 ea.**
- (32) **194839** Cover. 1955-64 all models. .... **\$25.85 ea.**
- (32) **1560244** Cover. 1965-66 all models. .... **\$22.80 ea.**
- (33) **G103883** Grease plug. 1955-57 all models. Takes 2. .... **\$1.40 ea.**
- (34) **G143999** Plug. 1955-57 all models. .... **\$2.65 ea.**
- (35) **G103869** Plug. 1955-58 all models. .... **\$2.65 ea.**
- (35) **G444752** Plug. 1959-66 all models. .... **85¢ ea.**
- (36) **G179890** Screw, differential cap. 1955-60. .... **\$2.65 ea.**

## Rear Axle Assembly

On "Rockne" the parts fit US-built cars only!

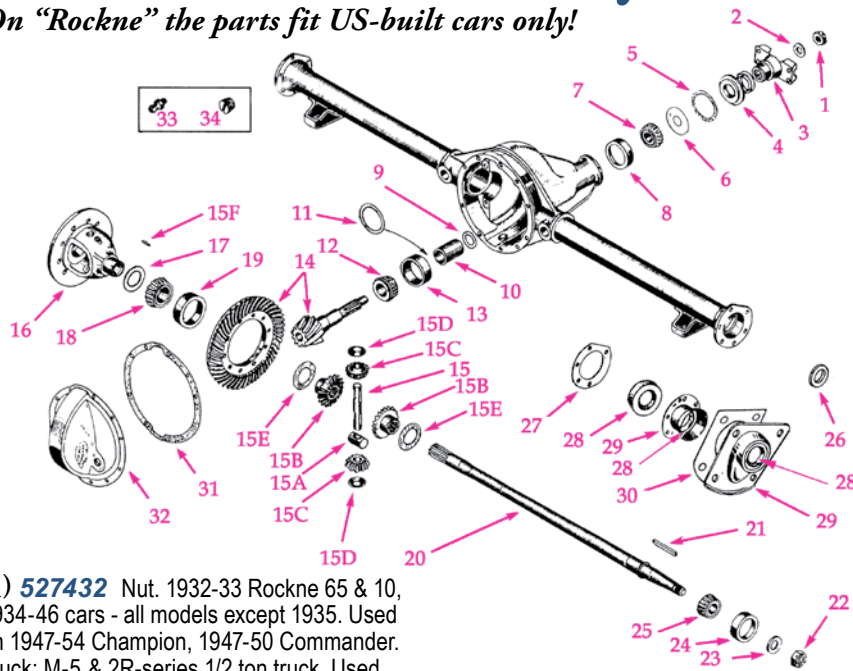

- (1) **527432** Nut. 1932-33 Rockne 65 & 10, 1934-46 cars - all models except 1935. Used on 1947-54 Champion, 1947-50 Commander. Truck: M-5 & 2R-series 1/2 ton truck. Used. .... **\$11.00 ea.**
- (1) **63X19** Nut. 1928-29 Dictator & Commander, 1932-33 Studebaker 6, 1935 car - all models. .... **\$5.30 ea.**
- (2) **196965** Washer. Car: 1932-33 Rockne 65 & 10, 1934-46 all. Truck: M-5 and 2R-series, 1947-54 Champion & 1947-50 Commander. .... **\$4.40 ea.**
- (3) **521825** Flange. Car: early 1936 Dictator, 1936-37 President, 1938-50 all. Truck: M-5 and 2R 1/2-ton truck. .... **\$71.50 ea.**
- (4 & 5) **199379X1 & 184161** Oil seal. Car: 1934-54 all. Trucks: 1/2-ton 1941-later. .... **\$16.00/set**
- (6) **537678** Slinger. Car: 1932-33 Rockne 65 & 10, 1934-54 all. Truck: 1/2-ton 1941-later. .... **\$16.75 ea.**
- (7) **510697** Cone & rollers. Car: 1932-33 Rockne 65 & 10, 1934-35 all & most 1936 Dictator & 1934 Commander 8. .... **\$38.50 ea.**
- (7) **510694** Cone & rollers, front. Car: 1935-37 President 8 & Canadian-built 1934-36 Dictator. .... **\$50.00 ea.**
- (7) **190033** Cone & rollers. Front. Some late 1934 and all 1935-46 Dictator, Champion & Commander, 1938-42 President. .... **\$40.50 ea.**
- (8) **510693** Cup, front pinion. 1932-33 Rockne 65 & 10, all US-built 1934-35 and most 1936 Dictators except 200 late '36 Coupes, also used on some Canadian-built 1934. .... **\$24.00 ea.**
- (8) **190032** Cup, front bearing. Used on 200 late 1936 Dictator Coupe and all 1937-50 Dictator, Commander and 1939-54 Champion. .... **\$17.50 ea.**
- (9) **190038-41** Shims .003, .005, .010, .030. Some late 1934 and all 1935-46 Dictator, Champion & Commander, 1938-42 President. .... **\$2.90 ea.**
- (10) **190037** Spacer. Some 1936 and all 1937-50 Dictator, Commander & 1939-54 Champion, 1938-42 President. .... **\$5.50 ea.**
- (11) **511652-4** Shims .003, .005, .010. 1934 Commander 8, Some 1936 Dictators, all 1937-50 Dictators, Commander, 1939-54 Champion and 1938-42 President. .... **\$2.90 ea.**

- (12) **510693** Cup, pinion rear bearing. 1932-33 Rockne 65 & 10, 1934-35 Dictator all except some Canadian-built 1934's. .... **\$24.00 ea.**
- (12) **511650** Cup, pinion rear bearing, Canadian-built. 1935 Dictator & all 1936 Dictator & Commander 8. .... **\$16.50 ea.**
- (12) **183904** Cup, pinion bearing rear. 1934 President having axles dated after April 11, 1934. .... **\$23.00 ea.**
- (12) **510694** Cone & rollers. 1932-33 Rockne 65 & 10, all US & some Canadian-built 1934 and all 1935 Dictators. .... **\$50.00 ea.**
- (13) **190035** Cup, pinion bearing rear. 1936-50 Dictator, Commander, 1939-54 Champion & 1938-42 President. .... **\$18.65 ea.**
- (13) **190036** Cone & roller, pinion rear. Some 1934 & all 1935-50 Dictator, Commander & 1939-54 Champion, and 1938-42 President. .... **\$51.00 ea.**
- (14) Gear set. .... Call for availability & price
- (15-15E) **524709** Differential side gear kit. 1938 Commander 8, 1936-50 Dictator, Commander, President which uses 36 Dictator rear axles. .... **\$175.00 ea.**
- (15-15F) **520188** Differential side gear kit. 1939-54 Champion. Used. .... **\$154.00 ea.**
- (15) **510721** Shaft. 1932-33 Rockne 65 & 10, all 1934-50 US-built, Dictator & Commander (and some Canadian), also 1934 Commander 8 & 1938-42 President. .... **\$31.90 ea.**
- (15) **194835** Shaft. 1939-54 Champion. .... **\$16.50 ea.**
- (15A) **510725** Thrust block. 1932-33 Rockne 65 & 10, 1934-37 US-built Dictator, some Canadian 1934's. .... **\$16.50 ea.**
- (15A) **511660** Thrust block. 1934 Dictator 8 & all 1938-50 Commander & President. .... **\$22.00 ea.**
- (15A) **194854** Thrust block. 1939-54 Champion. .... Only available in 520188 kit.
- (15B) **511677** Gear, side bevel. 1934 Commander 8, 1936-50 Dictator & Commander, 1938-42 President. Not used on some 1936 Dictators. Takes 2. .... **\$55.00 ea.**

Pre-War 1947-50 Commander, 1947-54 Champion, 1941-48 M5 truck & early 2R-Series 1/2-ton with Dana #41 Rear Axle

- (15B) **194834** Gear, side bevel. 1939-54 Champion. .... Order 520188 Differential side gear kit. .... **\$13.20 ea.**
- (15C) **510716** Pinion gear. 1934-42 Dictator except for some Canadian-built 1934's & 35's. Also used on 1934 Commander 8 & 1938-42 President. Takes 2. .... **\$33.00 ea.**
- (15C) **194833** Pinion gear. 1939-54 Champion. .... Order 520188 Differential side gear kit. .... **\$13.20 ea.**
- (15D) **511679** Thrust washer. 1934 Commander 8, 1936-42 US-built Dictator, Commander & Coupe Express and 1938-42 President. Takes 2. .... **\$13.20 ea.**
- (15D) **194836** Thrust washer. 1936-54 Champion. Takes 2. .... **\$7.70 ea.**
- (15E) **511678** Thrust washer. Same application as 511679. Limit 2 per customer. Takes 2. .... **\$13.20 ea.**
- (15E) **194838** Thrust washer. Same application as 194836. Takes 2. .... **\$7.70 ea.**
- (15F) **510722** Pin. 1934-50 Dictator, Commander & 1939-54 Champion, 1934 Commander 8, 1938-42 President, 1932-33 Rockne 65 & 10. .... **\$2.90 ea.**
- (16) **195117** Case. 1939-50 Commander, President, and Coupe Express, 1941-48 M5 and early 2R-series 1/2-ton truck. All with 4:55 or 4:82 ratio and Dana #41 rear axle. .... No Stock
- (16) **196313** Case. 1939-54 Champion except 1950-54 with 3:54 gear ratio. .... **\$132.00 ea.**
- (16) **529399** Case. 1950-54 Champion with 3:54 gear ratio. .... **\$115.50 ea.**
- (17) **1549648-51** Shims .003, .005, .010, .030. 1932-33 Rockne 65 & 10, 1934-54 all except 1934-37 President. .... **\$2.20 ea.**
- (18) **181794** Cone & rollers. 1934 & 36 President. Takes 2. .... **\$33.00 ea.**
- (18) **190048** Cone & rollers. Some 1936 & all 1937 Dictator. All 1938-50 cars except Champion, all M-5 truck and early 2R-series 1/2-ton truck. Takes 2. .... **\$51.00 ea.**
- (18) **196287** Cone & rollers. 1939-54 Champion. Takes 2. .... **\$49.75 ea.**
- (18) **190047** Cup. Same application as 190048. Takes 2. .... **\$23.50 ea.**
- (19) **196286** Cup. Same application as 196287 bearing. Takes 2. .... **\$51.00 ea.**
- (20) **191707** Axle shaft. 1938-39 Commander, President & Coupe Express. Truck: all M-5 and early 2R-Series 1/2-ton. Takes 2. .... **\$195.00 ea.**
- (20) **197570** Axle shaft. 1940 Commander & President. Takes 2. .... **\$110.00 ea.**
- (20) **197861** Axle shaft. 1941-42 Commander & President. Takes 2. .... **\$110.00 ea.**
- (20) **194840** Axle shaft. 1939-46 Champion. Takes 2. .... **\$104.50 ea.**
- (20) **521682** Axle shaft. 1947-50 Commander. .... **\$104.50 ea.**
- (20) **530449** Axle shaft. 1951-52 Champion. .... **\$93.50 ea.**
- (20) **1560422** Axle shaft. 1953-54 Champion. .... **\$93.50 ea.**
- (21) **510517** Key. 1932-33 Rockne 65 & 10, 1934-50 Dictator & Commander 6, 1938-42 President and Coupe Express. 1941 & later 1/2-ton truck. Takes 2. .... **\$2.45 ea.**
- (21) **194841** Key. 1939-54 Champion. Takes 2. .... **\$5.00 ea.**



- (22) **510516** Nut. 1934-37 Dictator & 1934 Commander 8. Takes 2. .... **\$10.65 ea.**  
 (22) **181782** Nut. 1934, '36 & '37 President, 1938-50 Commander, President & Coupe Express. 1941 & later 1/2-ton truck. Takes 2. .... **\$8.00 ea.**  
 (22) **537906** Nut. 1939-50 Champion. .... **\$8.00 ea.**  
 (23) **510518** Washer. 1934-37 Dictator & 1934 Commander 8. 1951-54 Champion. Used. Takes 2. .... **\$5.00 ea.**  
 (23) **G103348** Washer. 1934 & 1936-42 President, 1938-50 Commander & Coupe Express, 1941 & later 1/2-ton truck. .... **55¢ ea.**  
 (23) **196965** Washer. 1939-50 Champion. Takes 2. .... **\$4.40 ea.**  
 (24) **510728** Cone & rollers. 1932-33 Rockne 65 & 10 and 1934-37 Dictator. Takes 2. .... **\$36.00 ea.**  
 (24) **511664** Cone & rollers. 1934 Commander 8 and 1937 Coupe Express. Takes 2. .... **\$40.00 ea.**  
 (24) **192239** Cone & rollers. 1938-50 Commander, President & Coupe Express, 1941 and later 1/2-ton truck. .... **\$35.00 ea.**  
 (24) **194826** Cone & rollers. 1939-50 Champion. Takes 2. .... **\$169.50 ea.**  
 (24) **530451** Cone & rollers. 1951-54 Champion. .... **\$40.55 ea.**  
 (25) **165048** Cup. 1932-33 Rockne 65 & 10, 1934-37 Dictator. Takes 2. .... **\$27.00 ea.**  
 (25) **192238** Cup. Same application as 192239 cone & rollers. Takes 2. .... **\$18.50 ea.**  
 (25) **165167** Cup. 1939-54 Champion. Takes 2. .... **\$13.00 ea.**  
 (26) **516329** Inner axle seal. 1938-50 all cars except Champion, M-5 truck after serial #5, 111, all 2R 1/2-ton truck. Takes 2. .... **\$18.50 ea.**  
 (26) **516330** Inner axle seal. 1939-50 Champion. Takes 2. .... **\$20.00 ea.**  
 (27) **191723-6** Shims .003, .005, .010, .030. 1938-50 all cars except Champion. .... **\$4.40 ea.**  
 (27) **194844-6** Shims .005, .010, .030. 1939-54 Champion. Reconditioned/used. .... **\$4.25 ea.**  
 (28) **197591** felt seal. 1938-50 all cars except Champion, 1941 and later 1/2-ton truck. Takes 2. .... **\$4.25 ea.**  
 (28) **197216** Washer, felt. 1939-54 Champion. Takes 2. .... **\$2.75 ea.**  
 (29) **184805** Washer & retainer. 1935-37 Dictator & Coupe Express. Takes 2. .... **\$33.00 ea.**  
 (29) **193049** Washer & retainer. 1938-50 all cars except Champion, 1941 and later 1/2-ton truck. Takes 2. .... Call  
 (29) **533161** Washer & retainer. 1939-54 Champion. Takes 2. .... **\$20.00 ea.**  
 (30) **197436** Gasket. 1939-54 Champion. Takes 2. .... **\$1.50 ea.**  
 (31) **511674** Gasket. 1936-50 Dictator, Commander & Coupe Express, 1934 Commander 8, 1938-42 President. Truck: M5, early 2R5 & 6. .... **\$8.50 ea.**  
 (31) **1560245** Gasket. 1939-54 Champion. .... **\$10.00 ea.**  
 (32) **189952** Cover. 1936-50 Dictator & Commander, 1938-42 President. .... No Stock  
 (33) **G191758** Grease fitting. All 1936-50 cars plus 1934-35 Commander 8 & President. Takes 2. .... **\$3.30 ea.**  
 (34) **G103883** Grease plug. 1946-50 Champion. Takes 2. .... **\$1.40 ea.**  
**G105036** Cup, grease housing. 1934-35 Dictator. Takes 2. .... **\$5.25 ea.**

## Twin Traction Axle Related Parts for #23, #27 & #44 Rear Axles

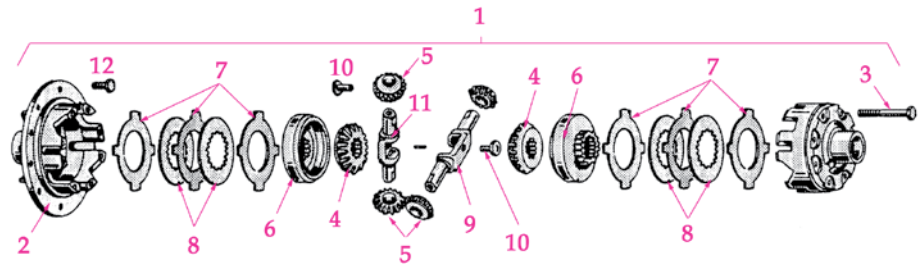

- (1) **1553368** Case assembly. 1959-60 with #23 rear axle having 3:31, 3:54, or 3:73 gear ratio. .... No Stock  
 (1) **1559521** Case assembly. 1963-65 cars with #27 rear axle having 4:10 or 4:56 rear ratio and with tapered axles. .... **\$303.60 ea.**  
 (1) **1562443** Case assembly. 1965-66 with #27 flanged rear axle having 3:31 or 3:37 gear ratio. .... **\$303.60 ea.**  
 (1) **1562444** Case assembly. 1965-66 with #27 flanged rear axle having 4:10 gear ratio. .... **\$303.60 ea.**  
 (2) **1553371** Case. 1959-60 with #23 rear axle having 3:31, 3:54 or 3:78 gear ratio. .... **\$196.95 ea.**  
 (2) **1553372** Case. 1959-60 with #23 rear axle having 4:10 or 4:27 gear ratio. .... **\$196.95 ea.**  
 (2) **1552108** Case. 1960-66 with #27 rear axle having 3:07, 3:31, 3:54 or 3:73 gear ratio. .... **\$196.95 ea.**  
 (2) **1544801** Case. Same as 1544802 except for vehicles having 3:07, 3:31, 3:54 or 3:73 gear ratio. .... **\$225.50 ea.**  
 (2) **1544802** Case. Late 1957, all 1958 and possibly 1959-64 with #44 rear axle having 3:92 - 4:55 gear ratio. .... **\$225.50 ea.**  
 (3) **1548338** Screw, case to case. 1959-64 with #23 or #27 rear axle. Takes 8. .... **\$2.20 ea.**  
 (3) **1544803** Screw, case to case. All 1957-58 and possibly 1959-64 with #44 rear axle. Takes 8. .... **\$2.20 ea.**  
 (4 & 5) **1548652** Gear kit. Differential side bevel. 1959-64 with #23 or #27 rear axle. .... **\$148.50 ea.**  
 (4 & 5) **1562439** Gear kit. Differential side bevel. 1965-66 with #27 flanged rear axle. .... **\$115.50 ea.**  
 (6) **1548340** Ring, differential side gear. 1959-64 with #23 or #27 rear axle. Takes 2. .... **\$82.50 ea.**  
 (6) **1562441** Ring, differential side gear. 1965-66 with #27 flanged rear axle. .... **\$82.50 ea.**  
 (6) **1544805** Ring. Late 1957 and all 58-64 with #44 rear axle. Takes 2. .... **\$99.00 ea.**  
 (7) **1545887** Plate .096-.101. Same application as 1545886. .... **\$13.75 ea.**  
 (7) **1548344** Plate. 1959 cars with #23 rear axle. Takes 4. .... **\$13.75 ea.**  
 (7) **1551336** Plate .059-.061. 1959-64 with #23 or #27 rear axle. Takes 2. .... **\$13.75 ea.**  
 (7) **1545886** Plate .092-.097. Late 1957, 1958-59 all models and possibly 1960-64 with #44 rear axle. 1957-59 takes 6, 1960 & later takes 4. .... No Stock  
 (8) **1548341** Disc. 1959-64 all models with #23 or #27 rear axle. Takes 2. .... **\$10.45 ea.**  
 (8) **1558565** Disc. 1963-64 with #23 or #27 rear axle. Takes 2. .... **\$10.45 ea.**  
 (7 & 8) **1559522** Plate & disc kit. 1959-66 all models with #23 or #27 rear axle. .... **\$69.30 ea.**  
 (7 & 8) **NEW Listing - 1563206** Plate & disc kit. 1957-66 all models with #44 rear axle. .... **\$145.00 ea.**  
 (9) **1549644** Shaft, cr differential pinion. 1959-64 with #23 or #27 rear axle. Takes 2. .... **\$42.35 ea.**  
 (10) **1548342** Thrust block. 1959-64 with #23 or #27 rear axle. Takes 2. .... **\$10.45 ea.**  
 (10) **1544810** Thrust block. Late 1957 and all 1958-64 with #44 rear axle. Takes 2. .... **\$22.00 ea.**

**REAR SPRING U-BOLTS** Many applications. Please use your Studebaker Chassis manual to determine correct size for your vehicle. Also see pg. 277.

- NEW LISTING - 519757** 7". 1947-49 Commander. .... **\$10.00 ea.**  
**NEW LISTING - 535732** 5.5". 1954 Champion wagon, 1955 Champion sedan, 1955 wagon with standard differential. .... **\$10.00 ea.**  
**NEW LISTING - 535733** 5.75". 1954-58 car, most models. .... **\$10.00 ea.**  
**NEW LISTING - 666233** 8". Truck: M-5 10, 11, 12, 2R-3E. .... **\$10.00 ea.**  
**NEW LISTING - 666370** 14.25". M16-17 with two speed rear axle. .... **\$14.00 ea.**  
**NEW LISTING - 677545X1** 12.875". .... **\$12.00 ea.**  
**NEW LISTING - 677545X3** 13.5". 2R-2E .... **\$14.00 ea.**  
**NEW LISTING - 677545X4** 15.25". .... **\$16.00 ea.**  
**NEW LISTING - 677545X7** 11.75". .... **\$12.00 ea.**  
**NEW LISTING - 677545X12** 14.75". .... **\$14.00 ea.**  
**NEW LISTING - 677721X1** 9.25". .... **\$10.00 ea.**  
**NEW LISTING - 678884X1** 8.25". .... **\$10.00 ea.**  
**NEW LISTING - 1558540** 5.5". 1963-66 Lark except station wagon with #27 rear axle and standard springs. .... **\$8.00 ea.**  
**NEW LISTING - 1558541** 5.875". 1963-66 6-cylinder station wagon with heavy duty springs. .... **\$8.00 ea.**

## Dana #44 Rear Axle 1951-66 Car, late 2R-8E Truck.

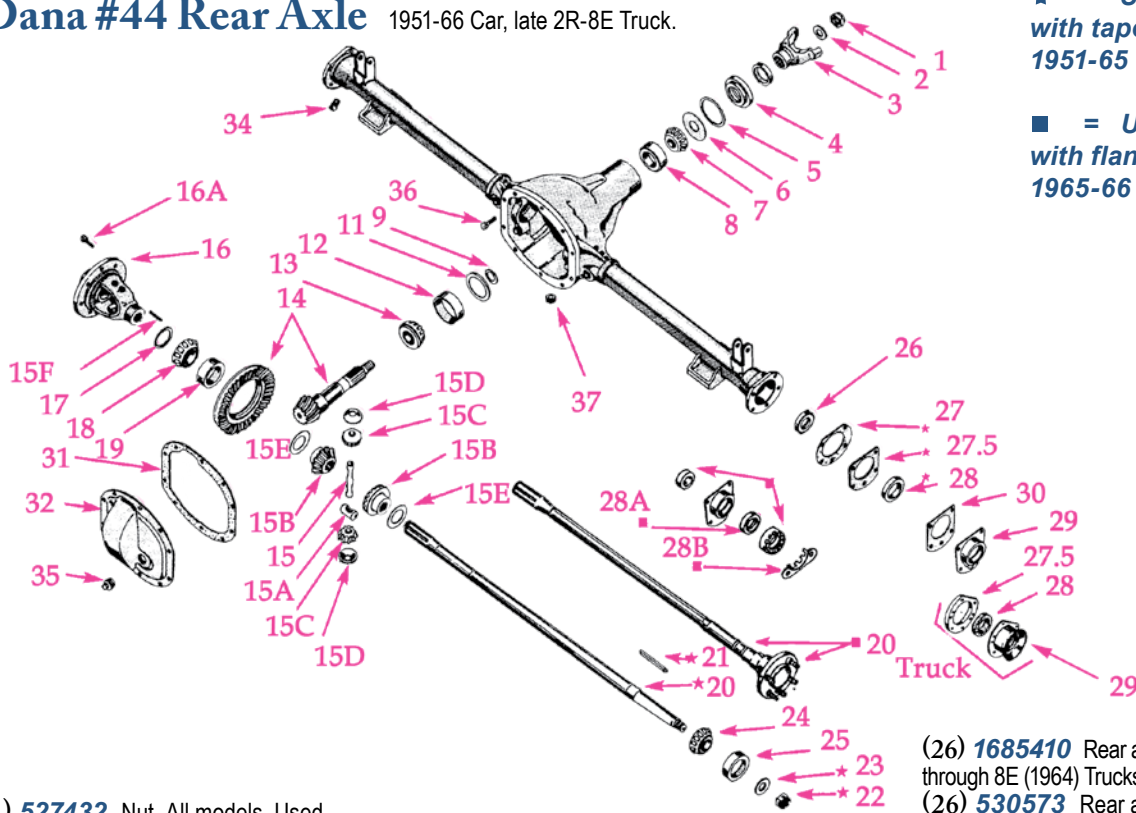

★ = Used with rear axle with tapered shafts.  
1951-65 car & truck

■ = Used with rear axle with flanged axle shafts.  
1965-66 car.

- (1) **527432** Nut. All models. Used.  
..... \$11.00 ea.
- (2) **196965** Washer. All models. **\$4.40 ea.**
- (3) **521825** Flange. All models. **\$71.50 ea.**
- (4 & 5) **199379X1** & **184161** Seal, rear pinion. All models. **\$16.00/set**
- (6) **537678** Slinger. All models **\$16.75 ea.**
- (7) **190033** Cone & rollers, front pinion shaft. All models. **\$40.50 ea.**
- (8) **190032** Cup, front pinion shaft. All models. **\$17.50 ea.**
- (9) **190038-41** Shims .003, .005, .010, .030. All models **\$2.90 ea.**
- (11) **511652-4** Shims .003, .005, .010. All models. **\$2.90 ea.**
- (12) **190035** Cup, rear pinion shaft. All models. **\$18.65 ea.**
- (13) **190036** Cone & rollers, rear pinion shaft. All models. **\$51.00 ea.**
- (14) Ring & pinion. Call (15-15F) **530705** Kit, differential side gear. All models. May contain some used parts. **\$214.50 ea.**
- (15) **1692002** Shaft. All models **\$31.90 ea.**
- (15A) **530706** Thrust block. All models **\$27.50 ea.**
- (15B) Gear, differential side bevel  
..... Order kit 530705
- (15C) Gear, differential pinion.  
..... Order kit 53075
- (15D) **511679** Thrust washer. All models. Takes 2. **\$13.20 ea.**
- (15E) **511678** Thrust washer. All models. Takes 2. **\$13.20 ea.**
- (15F) **510722** Pin. All models. **\$2.90 ea.**
- (16) **530702** Case. 3:92-4:56 gear ratio. **\$133.10 ea.**
- (16) **530703** Case. 3:07-3:73 gear ratio. Used. Call (16A) **527171** Screw. All models. Takes 8. **\$5.50 ea.**
- (17) **1549648-51** Shims .003, .005, .010 & .030. All models **\$2.20 ea.**

- (18) **190048** Cone & rollers. All models. Takes 2. **\$51.00 ea.**
- (19) **190047** Cup. All models. Takes 2. **\$23.50 ea.**
- (20) **191707** Axle shaft. 2R through E-series (1955) truck. Takes 2. **\$195.00 ea.**
- (20) **1685424** Shaft axle. 2E-1956 through 8E-1964 truck. Takes 2. Call
- (20) **530499** Axle shaft. 1951-52 Commander. Takes 2. **\$93.50 ea.**
- (20) **1558486** Axle shaft. 1953-65 cars with tapered axles **\$150.00 ea.**
- (20) **1562424** Axle shaft. 1965-66 with flanged axles. (Axle assemblies 1562422/423 available on page 293) Takes 2. **\$93.50 ea.**
- (21) **510517** Key. All trucks. Takes 2. **\$2.45 ea.**
- (21) **194841** Key. All cars with tapered axles. Takes 2. **\$5.00 ea.**
- (22) **181782** Nut. All trucks. Takes 2. **\$8.00 ea.**
- (22) **510516** Nut. All cars with tapered axles. Takes 2. **\$10.65 ea.**
- (23) **G103348** Washer. All trucks. Takes 2. **55¢ ea.**
- (23) **510518** Washer. All cars with tapered axles. Used. Takes 2. **\$5.00 ea.**
- (24) **192239** Axle cone & rollers. All trucks. Takes 2. **\$35.00 ea.**
- (24) **530451** Axle cone & rollers. All cars with tapered axles. Takes 2. **\$40.55 ea.**
- (24) **1562421** Axle cone & rollers. All cars with flanged axles. Takes 2. **\$41.50 ea.**
- (25) **192238** Cup, axle. All trucks. Takes 2. **\$18.50 ea.**
- (25) **165167** Cup. All cars. Takes 2. **\$13.00 ea.**
- (26) **516329** Rear axle seal, inner, 2R through E-series (1955) Trucks. Takes 2 **\$18.50 ea.**

- (26) **1685410** Rear axle seal, inner 2E (1956) through 8E (1964) Trucks. Takes 2. **\$25.50 ea.**
- (26) **530573** Rear axle seal, inner. All cars **\$18.00 ea.**
- (27) **191723-6** Shims .003, .005, .010, .030. All truck **\$4.40 ea.**
- (27) **194844-6** Shims .005, .010, .030. All cars. (Reconditioned). **\$4.25 ea.**
- (27.5) **193047** Reinforcement plate. All truck. Takes 2. **\$6.95 ea.**
- (27.5) **519383** Reinforcement plate. All cars. Takes 2. Used. **\$7.00 ea.**
- (28) **197591** Seal, felt. Subs for 191023 rear axle outer. 2R-8E truck. Takes 2. **\$4.25 ea.**
- (28A) **1562434** Seal, outer. 1965-66 cars with flanged axles. Takes 2. Call
- (28B) **1563292** Plate, ring lock. 1965-66 having flanged axles. Takes 2. **\$4.40 ea.**
- (29) **193049** Seal & rear liner. Trucks: 2R-8E. Call
- (29) **533161** Seal & retainer. All 1951-65 cars with tapered axles. Also includes (1) 197436 gasket. Takes 2. **\$20.00 ea.**
- (30) **197436** Gasket. All cars with tapered axles. Takes 4. **\$1.50 ea.**
- (30) **1562390** Gasket. 1965-66 with flanged axles. Takes 2. **\$1.10 ea.**
- (31) **1561783** Gasket. All models **\$10.00 ea.**
- (32) **530600** Cover. All models. **\$35.00 ea.**
- (34) **G103887** Grease plug. Truck: 2R through E-series. Takes 2. No longer available
- (34) **G103883** Grease plug. 2E-8E. Takes 2. **\$1.40 ea.**
- (35) **G103869** Filler plug. All models **\$2.65 ea.**
- (36) **G179890** Screw, differential bearing cap. All models. Takes 4. **\$2.65 ea.**
- (37) **G143999** Drain plug. 1951-58 car. Truck: 2R-6E. **\$2.65 ea.**
- (37) **684973** Drain plug. Truck: 7E & 8E. **\$8.45 ea.**
- (37) **G444672** Drain plug. 1959 Car. **\$8.45 ea.**